

HOLDER

A28 Type 95

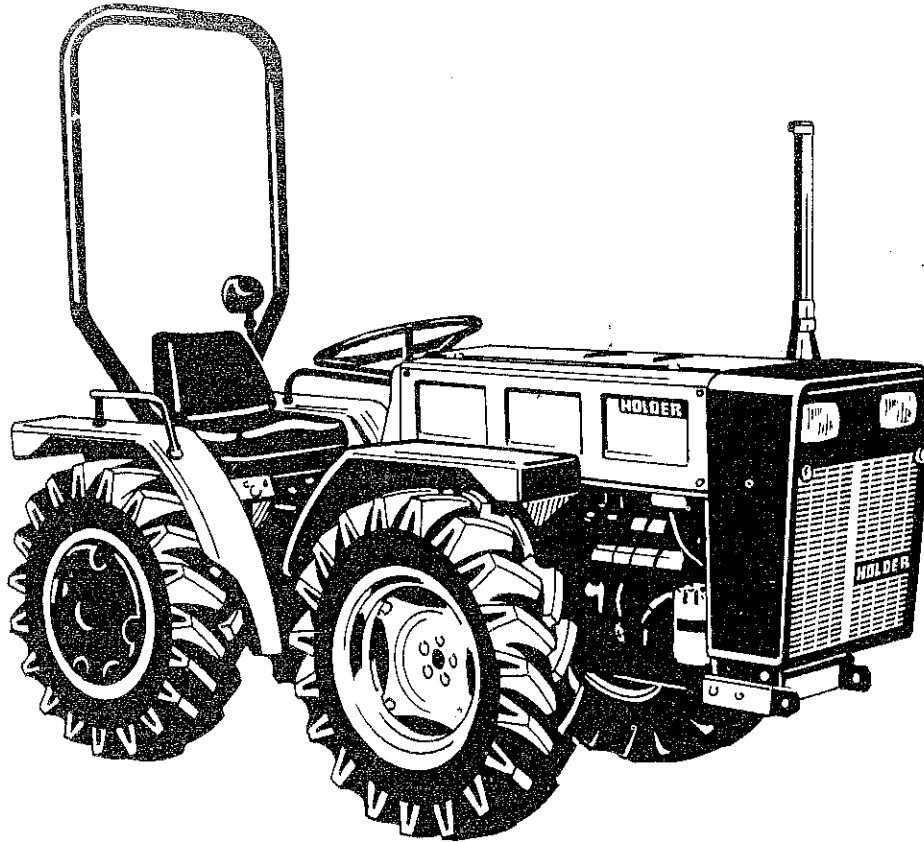

Ersatzteilliste für Allradschlepper Type A 28

Spare Parts List for Four Wheel Drive Tractor Type A 28

Bestell Nr. / Ref. No. - 117.366

Gebrüder Holder GmbH & Co.

D 7430 Metzingen/Germany · Postf. 1555 · Telefon 0 71 23/166-0 · Telex 7 245 319

1. Wichtig für Ersatzteilbestellungen!

Es wird gebeten, bei Ersatzteilbestellung folgendes anzugeben:

- 1) Motornummer bzw. Fahrgestellnummer.
- 2) Stückzahl, Bildnummer, Benennung des Teiles und Bestellnummer (im Zweifelsfall Muster einsenden).
- 3) Angabe der Versandart.
- 4) Deutliche und genaue Anschrift mit Post-bzw. Bahnstation.
- 5) Alle Ersatzteilbestellungen sollen über den zuständigen Vertreter eingereicht werden.
- 6) Defekte Teile sind frachtfrei mit Anhängenzettel an uns einzusenden. Der Anhängenzettel muss die genaue Anschrift des Absenders, Datum sowie Nr. des Briefes bzw. Berichtes haben. Altteile werden nur auf besonderen Wunsch unfrei zurückgeschickt.
- 7) **Bosch-Ersatzteile sind bei uns nicht vorrätig. Aus diesem Grunde bitten wir Sie, diese Ersatzteile von Ihrem nächsten Bosch-Service zu beziehen.**
- 8) Die Originalteile können geringfügig von der Abbildung abweichen. Geänderte Teile, die sich bildlich nicht unterscheiden, haben nach der Bildnummer den Zusatz - a.
- 9) Bei Ersatzteilbestellungen von geänderten Teilen sind die Angaben in Spalte 4 zu beachten.
- 10) Bei Ersatzteilbestellungen von DIN-Teilen ist an Stelle der Bezeichnung DIN der Buchstabe X einzusetzen. Für Bestellungen sollten unsere EDV-Bestellformulare benutzt werden.

2. Wichtig für Vertreter!

- a) Kundendienst.
Die wichtigsten Änderungen werden per Rundschreiben an alle Vertreter bekanntgegeben. Bei umfangreichen Änderungen wird die Ersatzteilliste neu überarbeitet bzw. ein neuer Mikrofilm erstellt.
- b) Masse (mm) und Gewichte (kg) sind im metrischen System eingetragen.
- c) In jeder Maschine wird vom Werk eine Betriebsanleitung beigelegt.
Alle Vertretungen erhalten je nach Betriebsgrösse und Maschinenabnahme eine bestimmte Anzahl Ersatzteillisten-Mikrofiche und Betriebsanleitungen als Erstausrüstung.
Zusätzlich angeforderte Betriebsanleitungen, Ersatzteillisten oder Mikrofilme werden zu unserem Selbstkostenpreis berechnet.

4410 Warendorf	Anton Schultz & Co. , Landtechnik Wilhelmstrasse 13	Tel. 02581/3903
5600 Wuppertal 2	Herbert Pens , Ing., Industriemotoren Wupperfelder Strasse 9-11	Tel. 0202/663656

Rheinland-Pfalz

5520 Bitburg	Math. Gangolf GmbH & Co. Saarstrasse 37	Tel. 06561/4041
6507 Ingelheim	Friedrich Bechtel KG Bahnhofstrasse 38-40	Tel. 06132/7031-32
5303 Konz	Gangolf-Salm & Co. GmbH Granastrasse 34-36	Tel. 06501/2054/55

Hessen

6301 Beuern	Reinhard Dort Neue Strasse 23	Tel. 06408/3029
3587 Borken- Trockenfurth	Bax & Schuchhardt GmbH In den Breiten 1	Tel. 05682/9278
6000 Frankfurt/M	Motoren-Richter KG Karl v. Drais-Strasse 6	Tel. 0611/542035
6108 Weiterstadt 1	Baumaschinen-Scheuermann Am Dornbusch 6	Tel. 06151/891941

Saarland

6600 Saarbrücken 3	Gebr. Greuter GmbH , Motoreninstandsetz. Bismarckstrasse 132	Tel. 0681/61755 + 61756 Tlx 04428654
--------------------	--	---

Baden-Württemberg

7605 Bad Griesbach	Karl Erdrich , Schlosserei- und Motoren- Instandsetzung Wilde Rench 46	Tel. 07806/635
7800 Freiburg	Willy Peetsch , Motoreninstandsetzung Zinkmattenstrasse 5	Tel. 0761/508989
7320 Göppingen	Widerhold Speidel Werkstätten f. Elektro- u Motorentchnik Am Autohof 1	Tel. 07161/68011
6900 Heidelberg	L. u. H. Hochstein GmbH & Co. Heuaerweg 21	Tel. 06221/71344-781124
7100 Heilbronn	Kurt Benz, Motorgeräte Hafenstrasse 4	Tel. 07131/84209
7768 Stockach	Konrad Keller , Landmaschinen-Reperatur Talstrasse 10	Tel. 07771/2588
7600 Offenburg- Windschläg	Herbert Oehler , Landmaschinen Windschlägerstrasse 107	Tel. 0781/4129
7583 Ottersweier	Josef Oechsle , Haus der Landtechnik Hubstrasse 33	Tel. 07223/23007
7000 Stuttgart- Feuerbach	Strohm & Gänssle KG Leobener Strasse 63	Tel. 0711/814471
7143 Vaihingen/E. Gündelsbach	Walter Krumm Land- u. Weinbautechnik	Tel. 07042/2933

Bayern

8900 Augsburg	Ulrich Hofmann , Motorgeräte Donauwörther Strasse 79	Tel. 0821/416788
8391 Entscheneuth	Köppl GmbH , Agrartechnik Post Saldenburg	Tel. 09907/335
8870 Günzburg	Ulrich Hofmann , Motorgeräte Parkstrasse 4	Tel. 08221/5044-5045
8500 Nürnberg	Müller & Kraus Motoren-Instands u. Motorgeräte Regemsburger Strasse 36	Tel. 0911/463365

8711 Sulzfeld	Willy Frieg Jahnstrasse 1	Tel. 09321/6437
8540 Schwalbach	IMA GmbH Regnitzhembach, Ziegelstrasse 7-11	Tel. 09122/4024
8602 Unterneuses	Ernst Bauer & Sohn Hauptstrasse 31	Tel. 09546/247
8075 Vohburg/Donau	Josef Pflügl GmbH Austrasse 11-13	Tel. 08457/1063 Tlx. 055612
8120 Weilheim i. OB	Ernst Bauer & Sohn Paradeisstrasse 56	Tel. 0881/4491 Tlx. 059877

WIE BESTELLT MAN DIE ERSATZTEILE

BEMERKUNG

Bei Bestellung ist stets folgendes anzugeben:

- TYP UND AUSFUEHRUNG DER MASCHINE
- SERIENNUMMER DER MASCHINE
- BESTELLNUMMER DES TEILES
- GEWUENSCHTE STUECKZAHL
- GEWUENSCHTES VERSAND MITTEL
- ADRESSE DES BESTELLERS

BESTIMMUNG DES TEILS

– Auf dem Bild das betreffende Teil aufsuchen (die Maschine ist in genauen Gruppen unterteilt, wie aus dem Verzeichnis der Abbildungen hervorgeht).

– Die Bestellnummer ablesen. Falls diese Nummer kein danebenstehendes Symbol hat, gilt sie fuer alle Maschinen die oben rechts auf dem Bild angefuert sind.

Wenn ein oder mehrere Symbole neben der Bestellnummer stehen, oder wenn ein und dasselbe Teil mehrere Nummern mit Symbolen hat, ist das gewuenschte Teil durch Lesen der Symbolbedeutung festzusetzen.

Fuer einen besseren Betrieb, Sicherheit und Garantie der Maschine, nur ORIGINALERSATZTEILE verwenden!

IM ERSATZTEILKATALOG VERWENDETE KURZZEICHEN

(Die genannten Zahlen sind nur Beispiele)

– RUNDE ZEICHEN - ○●◐◑◒◓ usw.

Gueltigkeitsbezeichnungen fuer Maschinentype

Beispiel:

● Die hiermit bezeichneten Teile gelten nur fuer Maschine Mod. "1200"

– VIERECKE - □■▣▤▥ usw.

Gueltigkeitsbezeichnungen fuer Einzelteile

Beispiel:

□ → 585001 Das auf diese Weise bezeichnete Teil gilt fuer Maschinen bis Seriennummer 585001

■ 585002 → Das auf diese Weise bezeichnete Teil gilt fuer Maschinen ab Seriennummer 585002

– DREIECKE - △▲△▽▽▽ usw.

Gueltigkeitsbezeichnungen fuer die seitlich angegebenen Untergruppen.

Die DREIECKSYMBOLS sind stets den nachstehenden Zeichen zugeordnet

Untergruppensymbole

MOTOREN

z.B. △  H2000P : Hiermit wird ein Motor H2000P bezeichnet

FRAESEN MIT FESTER HAUBE

z.B. △  cm 100 : Hiermit wird eine Fraese mit fester Haube von 100 cm bezeichnet

FRAESEN, MIT VERSTELLBARER HAUBE

z.B. △  cm 75 : Hiermit wird eine Fraese mit verstellbarer Haube von 75 cm bezeichnet

RAD MIT VERSTELLBARER SCHEIBE

z.B. △  5.00-12 Zeigt das Rad mit verstellbarer Scheibe Typ 5.00-12

RAD MIT FESTER SCHEIBE

z.B. △  6.5-15 Zeigt das Rad mit Scheibe Typ 6.5-15

LAENGE ANZUGEBEN

z.B.  100 Bedeutet, dass das betreffende Detail des langen Typs ist

PUMPEN

z.B. △  SL985 : Hiermit wird eine Hydraulikpumpe Type SL985 bezeichnet

ELEKTRISCHE ANLAGE

z.B. △  EXPORT : Hiermit wird eine elektrische Anlage fuer Maschinen in Export-Ausfuhrung bezeichnet

DICHTUNG

z.B. △  J284 : Hiermit wird der Typ J284 bezeichnet

MAEHBALKEN

z.B. △  cm 125 : Hiermit wird ein 125 cm breiter Maehbalken bezeichnet

MESSERKLINGEN

z.B. △  mm 38 : Hiermit werden Zaehne mit 38 mm Achsabstand bezeichnet

MASCHINENTYPE

z.B. △  99 : Gilt fuer Maschine Mod. 99

– STERNZEICHEN



Gueltigkeitsbezeichnungen fuer Standard-Teile, Teile auf Anfrage. Teile eines anderen Herstellers

* A.R. Das auf diese Weise bezeichnete Teil wird nur auf Anfrage des Kunden geliefert.

⊗ STANDARD Das hiermit bezeichnete Teil ist bei normaler Ausfuhrung bzw. Montage vorgesehen

⊠ Firma S.p.A. Das auf diese Weise angegebene Teil gilt nur fuer den genannten Kunden

– KURZZEICHEN

 = Links
 = Rechts

 = SIEHE NAECHSTE SEITE

Bild Fig.	1-2-3	KARROSSERIE <i>BODY</i>
Bild Fig.	4-5	KUPPLUNG UND ENTSPRCHENDE STEUREUNGEN <i>CLUTCH AND CONTROL</i>
Bild Fig.	6-7	WECHSELGETRIEBE-STEUERUNGEN <i>GEARBOX SHIFTING MECHANISM</i>
Bild Fig.	8	GETRIEBEGEHÄUSE <i>GEAR BOX</i>
Bild Fig.	9-10-11	WECHSELGETRIEBE-ZAHNRÄDER <i>GEARS</i>
Bild Fig.	12-13	VORDERWELLEN GEHÄUSE UND DIFFERENTIAL <i>FRONT AXLE SHAFTS AND DIFFERENTIAL</i>
Bild Fig.	14-15	MITTLEREGEHÄUSE <i>INTERMEDIATE HOUSING</i>
Bild Fig.	16-17	HINTERWELLEN <i>REAR AXLE</i>
Bild Fig.	18-19	AUSGLEICHSGETRIEBE UND HINTERWELLEN <i>DIFFERENTIAL AND REAR AXLE SHAFTS</i>
Bild Fig.	20-21	BREMSEN <i>BRAKES</i>
Bild Fig.	22	RÄDER <i>WHEELS</i>
Bild Fig.	23-24	ELEKTRISCHE ANLAGE <i>ELECTRICAL SYSTEM</i>
Bild Fig.	25	DREIPUNKT-ANSCHLUSS <i>THREE POINT HITCH CONNECTION</i>
Bild Fig.	26	ZUBEHÖR <i>ACCESSORIES</i>
Bild Fig.	27	HYDRAULIKANLAGEN – HYDROFÜHRUNG UND NORMAL KRAFTHEBER <i>HYDRAULIC SYSTEM – HYDRAULIC STEERING AND STANDARD LIFTER</i>
Bild Fig.	28	HYDROFÜHRUNG UND LAGERUNG <i>HYDRAULIC STEERING AND SUPPORT</i>
Bild Fig.	29	PUMP <i>PUMP</i>
Bild Fig.	30	ÖLFILTER <i>FILTER</i>
Bild Fig.	31	HYDRAULISCHE ANSCHLÜSSE SCHALTGETRIEBE <i>HYDRAULIC CONNECTIONS FOR GEARBOX</i>
Bild. Fig.	32	VERTEILER <i>DISTRIBUTOR</i>
Bild Fig.	33	VERTEILER UND DETAILS <i>DISTRIBUTOR AND DETAILS</i>
Bild Fig.	34	LENKZYLINDER <i>STEERING JACK</i>
Bild Fig.	35	ZYLINDER DER KRAFTHEBERS <i>POWER-LIFT JACK</i>

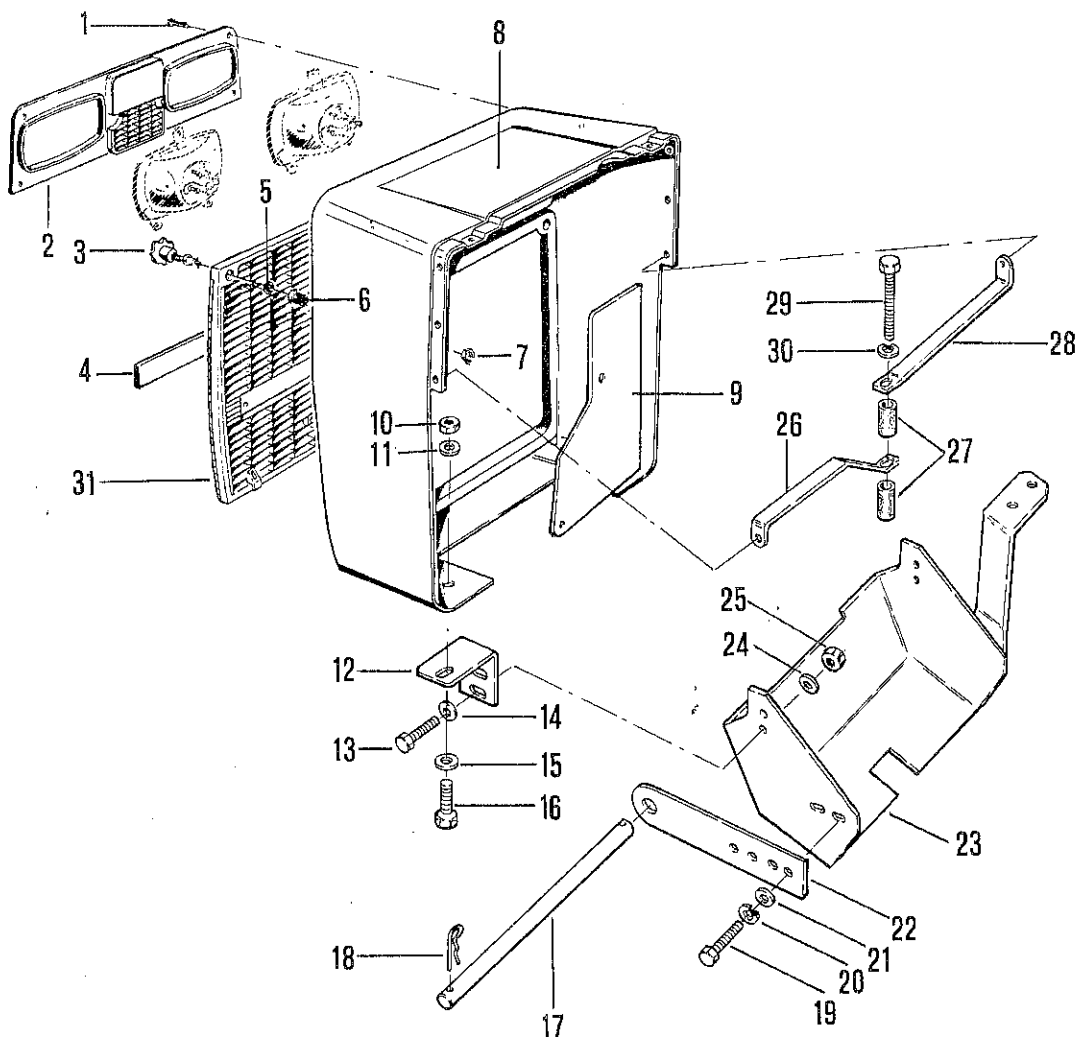

TPS-NL 83-316

No. pezzo No. piece No. pièce No. Bild No. pieza	No. di ordinazione Part No. No. de commande Bestell. - Nr. No. de pedido	No. pezzo No. piece No. pièce No. Bild No. pieza	No. di ordinazione Part No. No. de commande Bestell. - Nr. No. de pedido	No. pezzo No. piece No. pièce No. Bild No. pieza	No. di ordinazione Part No. No. de commande Bestell. - Nr. No. de pedido
1	DIN7985M4x20	18	81.0625.010		
2	6080.182.01.37	19	86.3276.000		
3	000.994.03.01	20	84.3755.000		
4	000.004.18.01	21	84.3807.000		
5	000.994.02.03	22	11.0033.343		
6	000.994.02.02	23	19.0033.890		
7	000.990.66.50	24	84.3643.060		
8	19.0033.897	25	81.4569.000		
-	6080.164.01.31	26	19.0033.885		
9	19.0033.889	27	19.0033.883		
10	81.4627.000	28	19.0033.886		
11	84.3807.000	29	86.3149.000		
12	19.0033.881	30	84.3755.000		
-	19.0033.882	31	6080.164.01.28		
13	86.2670.000				
14	84.3685.000				
15	84.3807.000				
16	86.3275.000				
17	19.0033.887				

Gultigkeitsvermerk
Usage Code

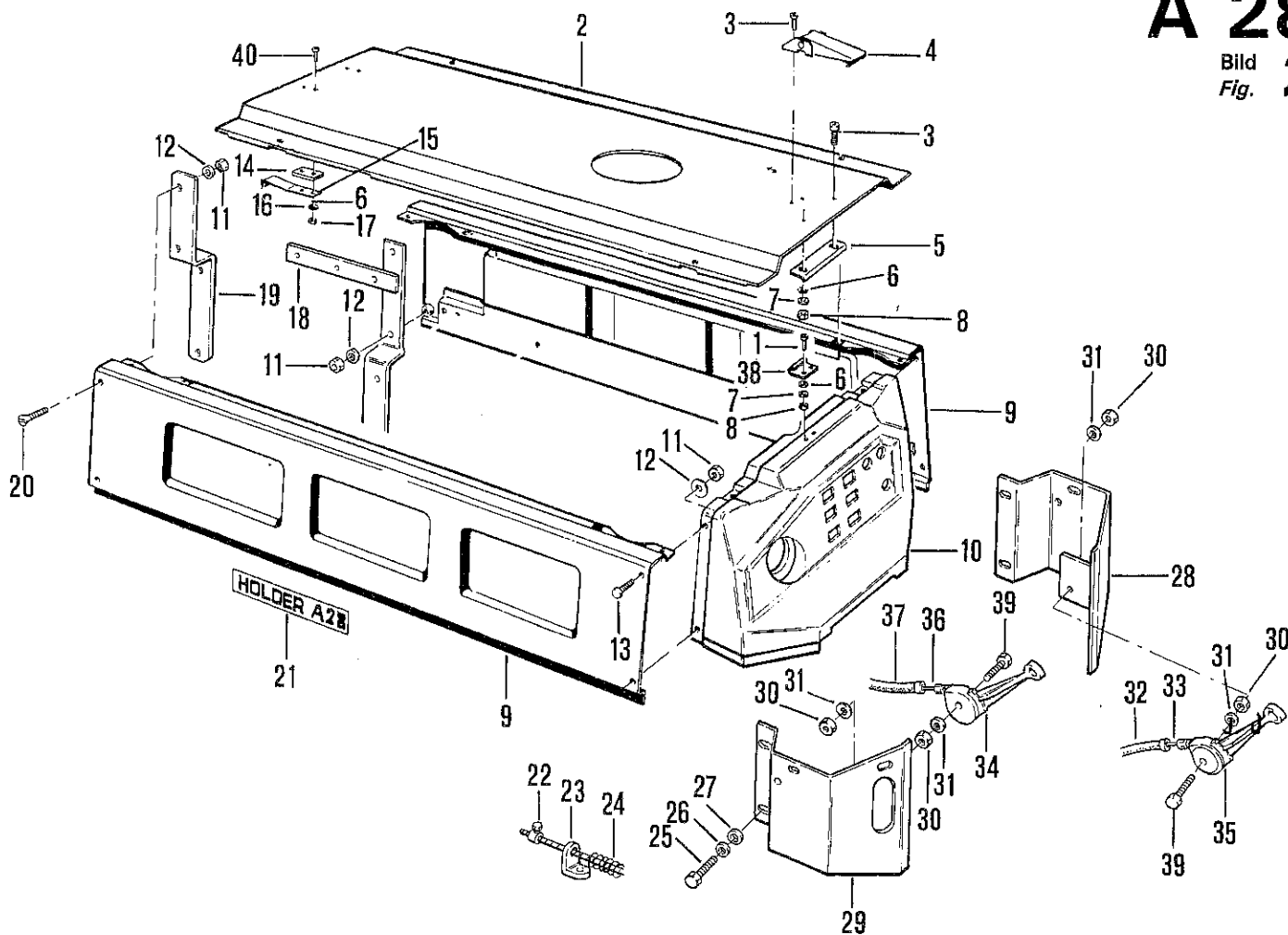

No. pezzo No. piece No. pièce No. Bild No. pieza	No. di ordinazione Part No. No. de commande Bestell. - Nr. No. de pedido	No. pezzo No. piece No. pièce No. Bild No. pieza	No. di ordinazione Part No. No. de commande Bestell. - Nr. No. de pedido	No. pezzo No. piece No. pièce No. Bild No. pieza	No. di ordinazione Part No. No. de commande Bestell. - Nr. No. de pedido
1	86.1934.045	19	19.0033.895	38	000.993.01.92
2	19.0035.120	20	86.2148.000	39	86.2095.010
3	86.1928.090	21	19.0033.985	40	86.1927.020
4	000.993.01.87	22	85.9007.000		
5	6080.164.01.52	23	11.0015.204		
6	84.3542.000	24	83.1139.050		
7	84.3561.000	25	86.2488.000		
8	81.4525.000	26	84.3685.000		
9	19.0035.118	27	84.3605.010		
-	19.0035.119	28	19.0033.441		
10	19.0033.880	29	19.0033.877		
11	81.4535.050	30	81.4546.000		
12	84.3605.010	31	84.3570.000		
13	86.2148.000	32	85.7004.000		
14	6080.164.01.67	33	85.6147.000		
15	000.992.18.32	34	82.8029.080		
16	84.3561.000	35	82.8029.060		
17	81.4525.000	36	85.6148.050		
18	19.0033.894	37	85.7071.000		

Gültigkeitsvermerk
Usage Code

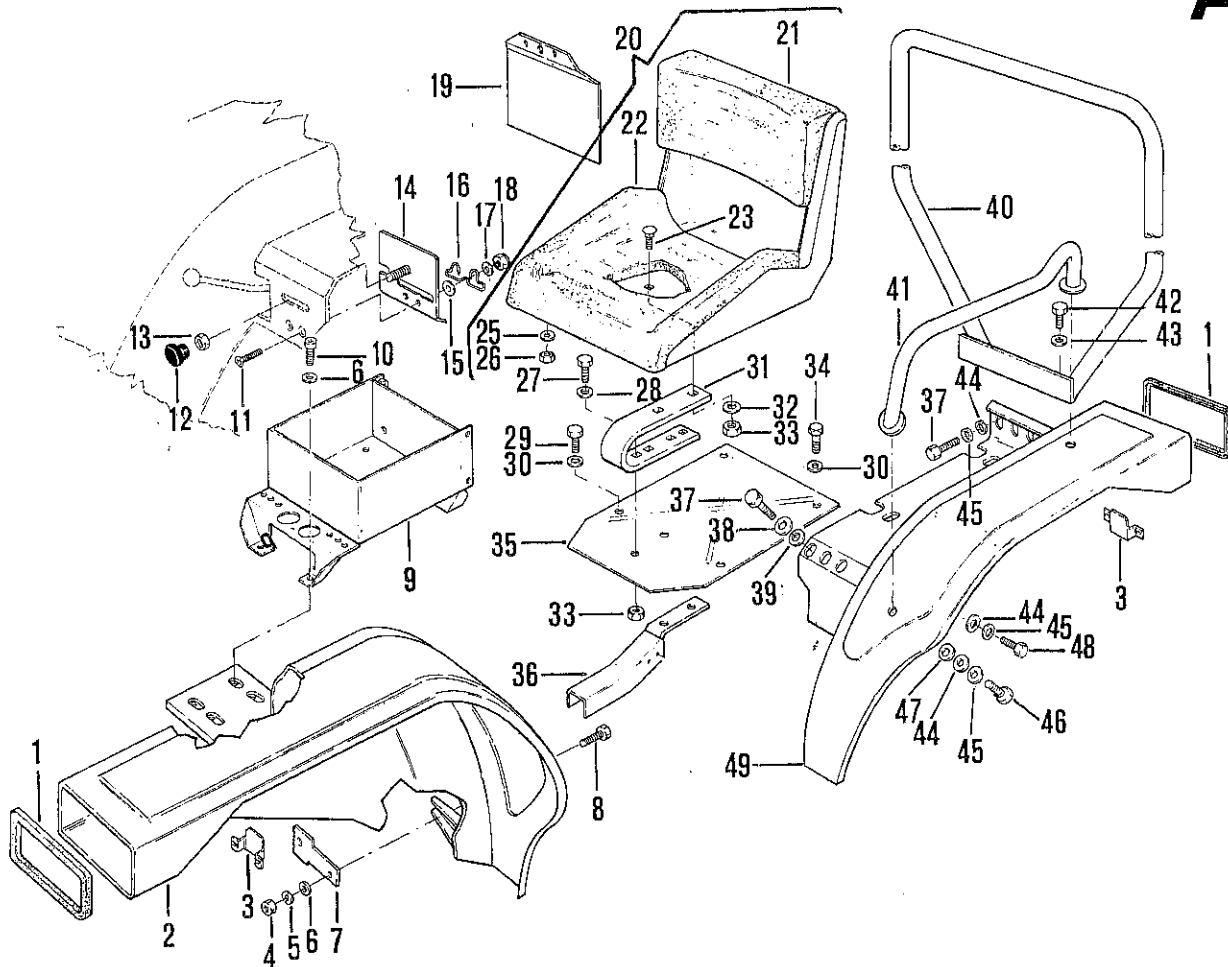

No. pezzo No. piece No. pièce No. Bild No. pieza	No. di ordinazione Part No. No. de commande Bestell. - Nr. No. de pedido	No. pezzo No. piece No. pièce No. Bild No. pieza	No. di ordinazione Part No. No. de commande Bestell. - Nr. No. de pedido	No. pezzo No. piece No. pièce No. Bild No. pieza	No. di ordinazione Part No. No. de commande Bestell. - Nr. No. de pedido
1	25.6808.000	19	19.0033.891	38	84.3755.000
2	19.0033.559	20	19.0035.114	39	84.3807.000
—	19.0033.560	21	15.0035.536	40	19.0033.875 *
3	19.0033.514	22	15.0033.535	41	19.0033.582
4	81.4644.000	23	86.3861.000	—	19.0033.583
5	84.3807.000	24		42	86.3997.010 *
6	84.3755.000	25	84.3619.000	43	84.3843.060 *
7	19.0033.513	26	81.4552.000	44	84.3807.000
8	86.3276.000	27	86.3740.000	45	84.3755.000
9	19.0035.102	28	84.3843.060	46	86.3206.000
10	86.3206.000	29	86.3254.000	47	47.3887.000
11	86.2183.000	30	84.3755.000	48	86.3206.000
12	83.7553.000	31	19.0033.286	49	19.0033.568
13	81.4647.000	32	84.3843.060	—	19.0033.569
14	19.0035.107	33	81.4706.050		
15	19.0035.106	34	86.3172.050		
16	19.0035.105	35	19.0031.275		
17	84.3619.000	36	19.0033.699		
18	81.4548.000	37	86.3206.000		

* A R.

Gültigkeitsvermerk
Usage Code

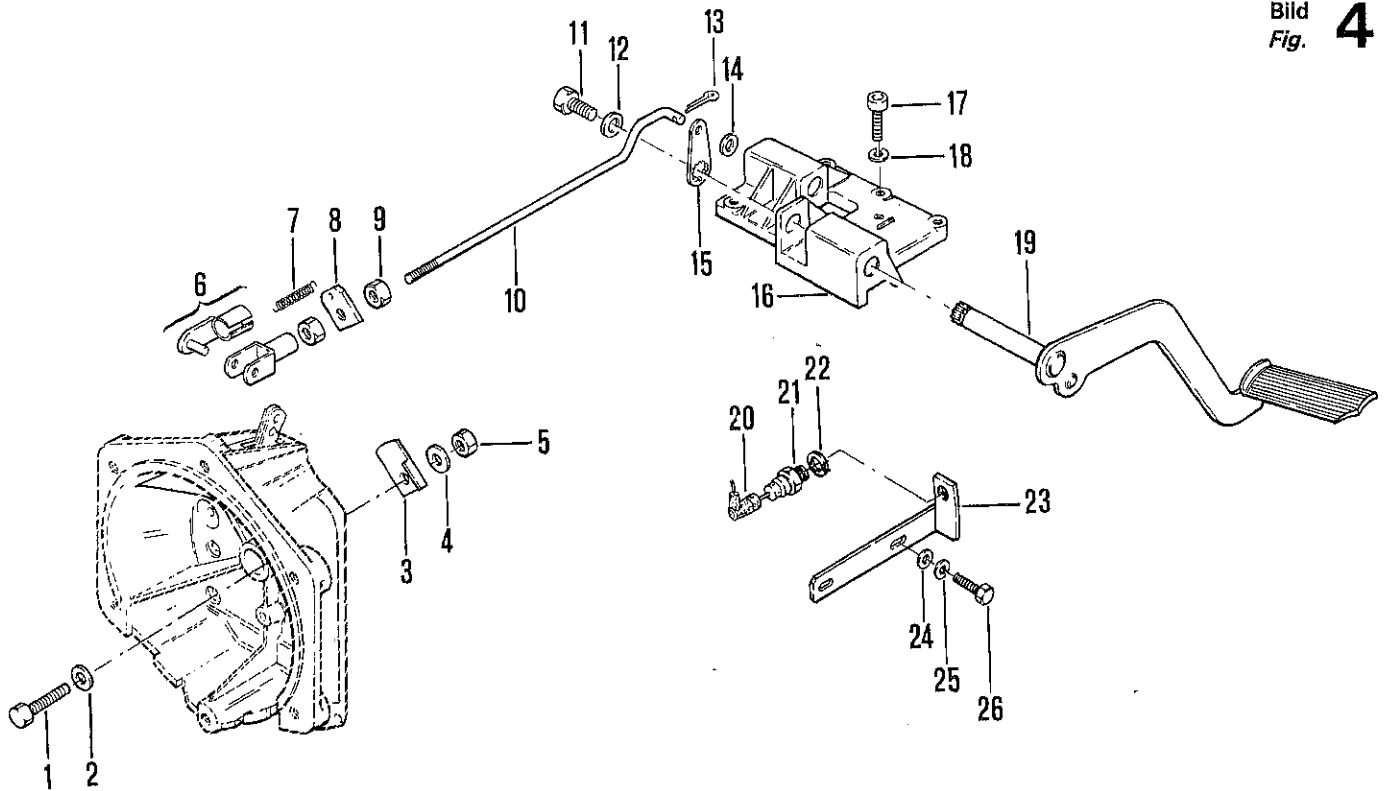

No. pezzo No. pièce No. pièce No. Bild No. pieza	No. di ordinazione Part No. No. de commande Bestell. - Nr. No. de pedido	No. pezzo No. pièce No. pièce No. Bild No. pieza	No. di ordinazione Part No. No. de commande Bestell. - Nr. No. de pedido	No. pezzo No. pièce No. pièce No. Bild No. pieza	No. di ordinazione Part No. No. de commande Bestell. - Nr. No. de pedido
1	86.2908.000	20	82.5117.010		
2	82.4023.000	21	82.5117.000		
3	19.0005.262	22	84.4030.000		
4	84.3649.000	23	19.0033.873		
5	81.4570.000	24	84.3807.000		
6	86.0060.000	25	84.3775.050		
7	83.1139.000	26	86.3276.000		
8	19.0016.203				
9	81.4580.000				
10	19.0016.201				
11	86.3149.000				
12	84.3818.000				
13	81.0505.000				
14	84.3685.000				
15	19.0016.202				
16	19.0006.013				
17	86.3347.050				
18	84.3755.000				
19	19.0033.278				

Gültigkeitsvermerk
Usage Code

A 28

Bild
Fig. 5

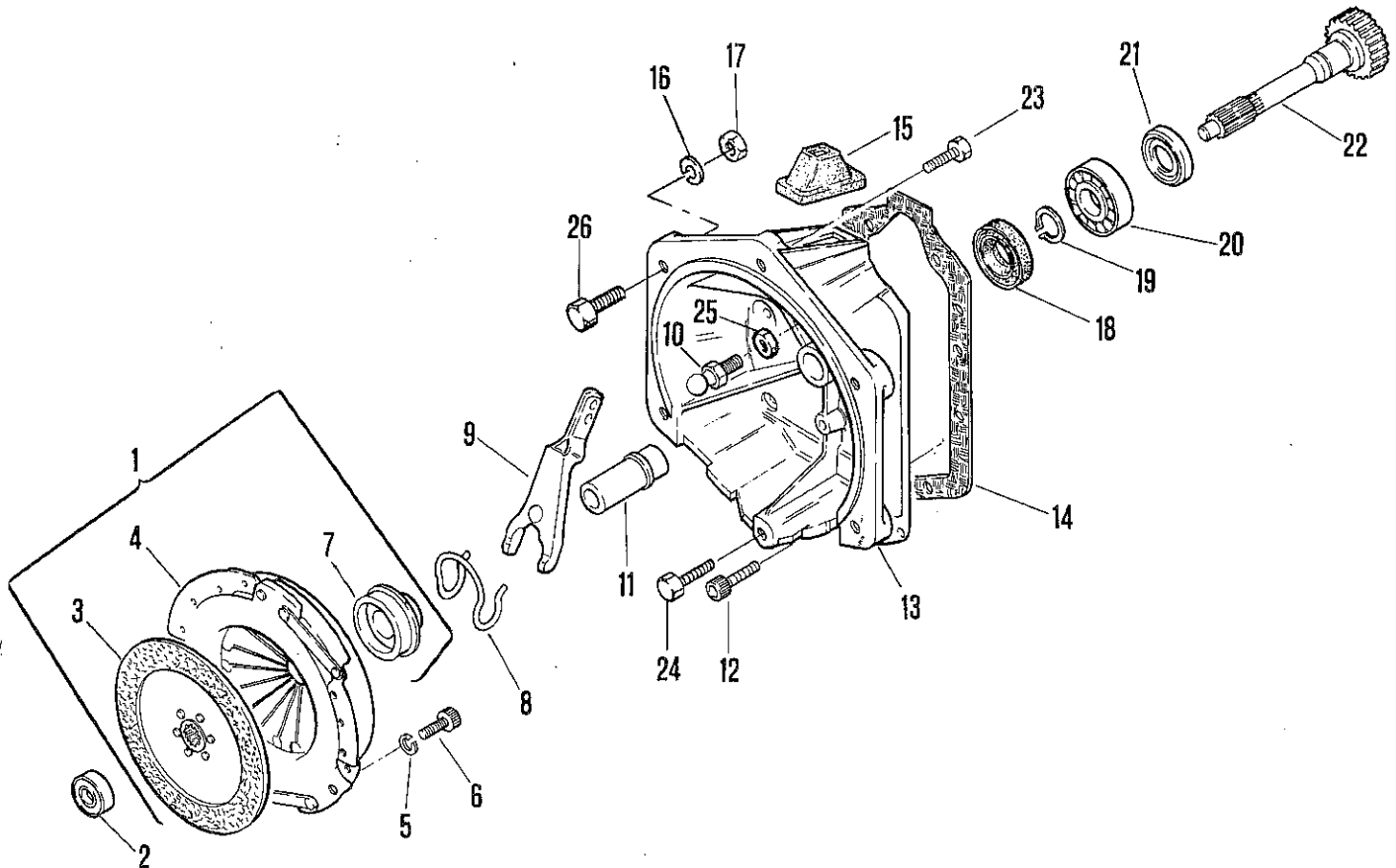

No. pezzo No. pièce No. pièce No. Bild No. pieza	No. di ordinazione Part No. No. de commande Bestell. - Nr. No. de pedido	No. pezzo No. pièce No. pièce No. Bild No. pieza	No. di ordinazione Part No. No. de commande Bestell. - Nr. No. de pedido	No. pezzo No. pièce No. pièce No. Bild No. pieza	No. di ordinazione Part No. No. de commande Bestell. - Nr. No. de pedido
1	81.9180.000	20	81.2719.050		
2	81.2574.000	21	19.0006.204		
3	81.9160.020	22	19.0006.100		
4	81.9160.010	23	86.3451.050		
5	84.3571.000	24	86.3347.050		
6	86.2097.000	25	84.3754.080		
7	81.9160.030	26	86.3451.050		
8	81.9134.050				
9	81.9134.010				
10	81.9134.040				
11	19.0006.202				
12	86.3385.050				
13	19.0006.010				
14	19.0005.905				
15	19.0016.900				
16	84.3755.000				
17	81.4644.000				
18	80.2093.050				
19	80.1185.000				

Gultigkeitsvermerk
Usage Code

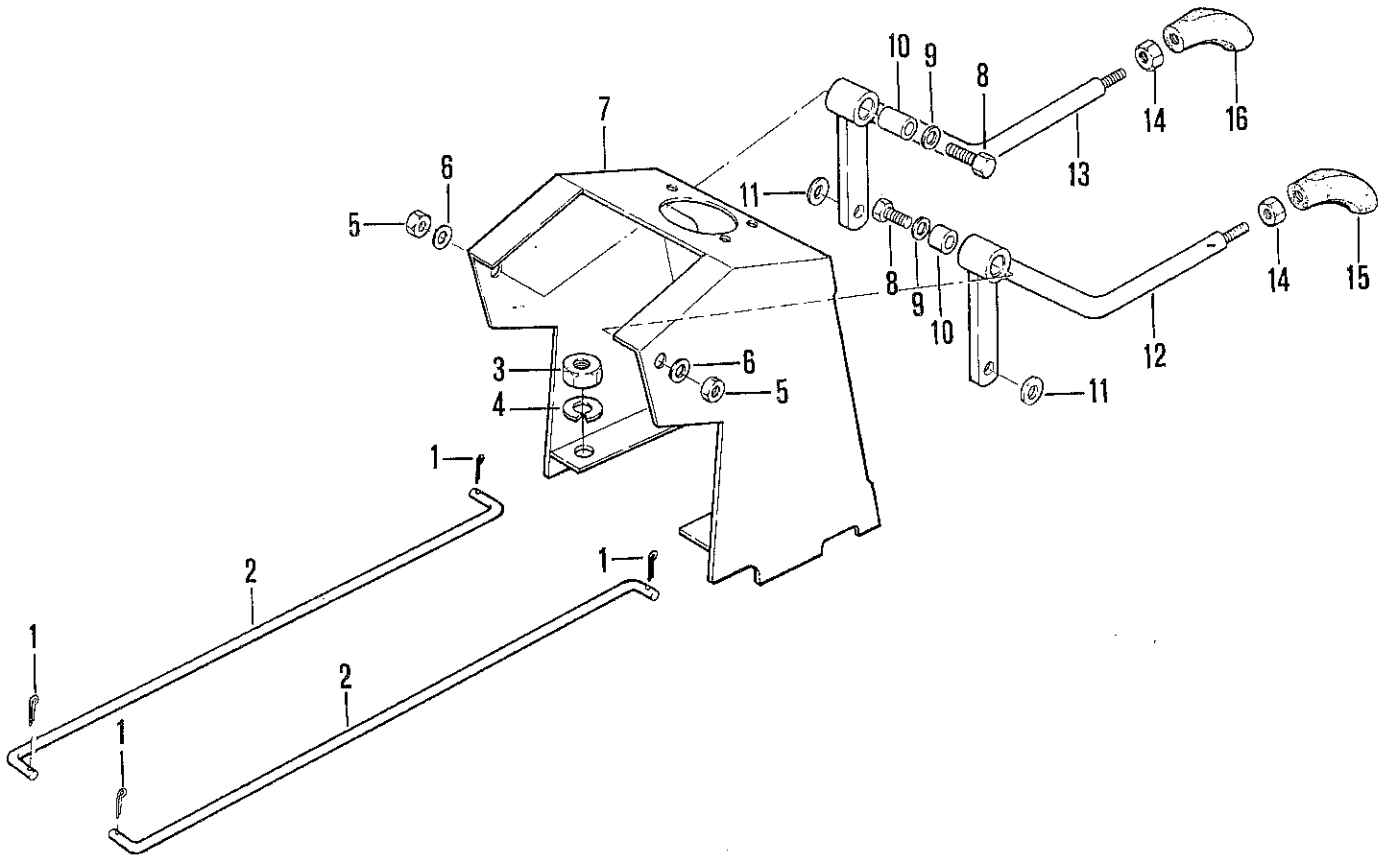

No. pezzo No. pièce No. Bild No. pieza	No. di ordinazione Part No. No. de commande Bestell. - Nr. No. de pedido	No. pezzo No. pièce No. Bild No. pieza	No. di ordinazione Part No. No. de commande Bestell. - Nr. No. de pedido	No. pezzo No. pièce No. Bild No. pieza	No. di ordinazione Part No. No. de commande Bestell. - Nr. No. de pedido
1	81.0505.000				
2	19.0006.212				
3	81.4706.050				
4	84.3843.060				
5	81.4644.000				
6	84.3755.000				
7	19.0030.265				
8	19.0006.217				
9	84.3927.050				
10	80.4051.000				
11	84.3807.000				
12	19.0006.216				
13	19.0006.215				
14	81.4624.000				
15	83.7533.100				
16	83.7533.090				

Gultigkeitsvermerk
Usage Code

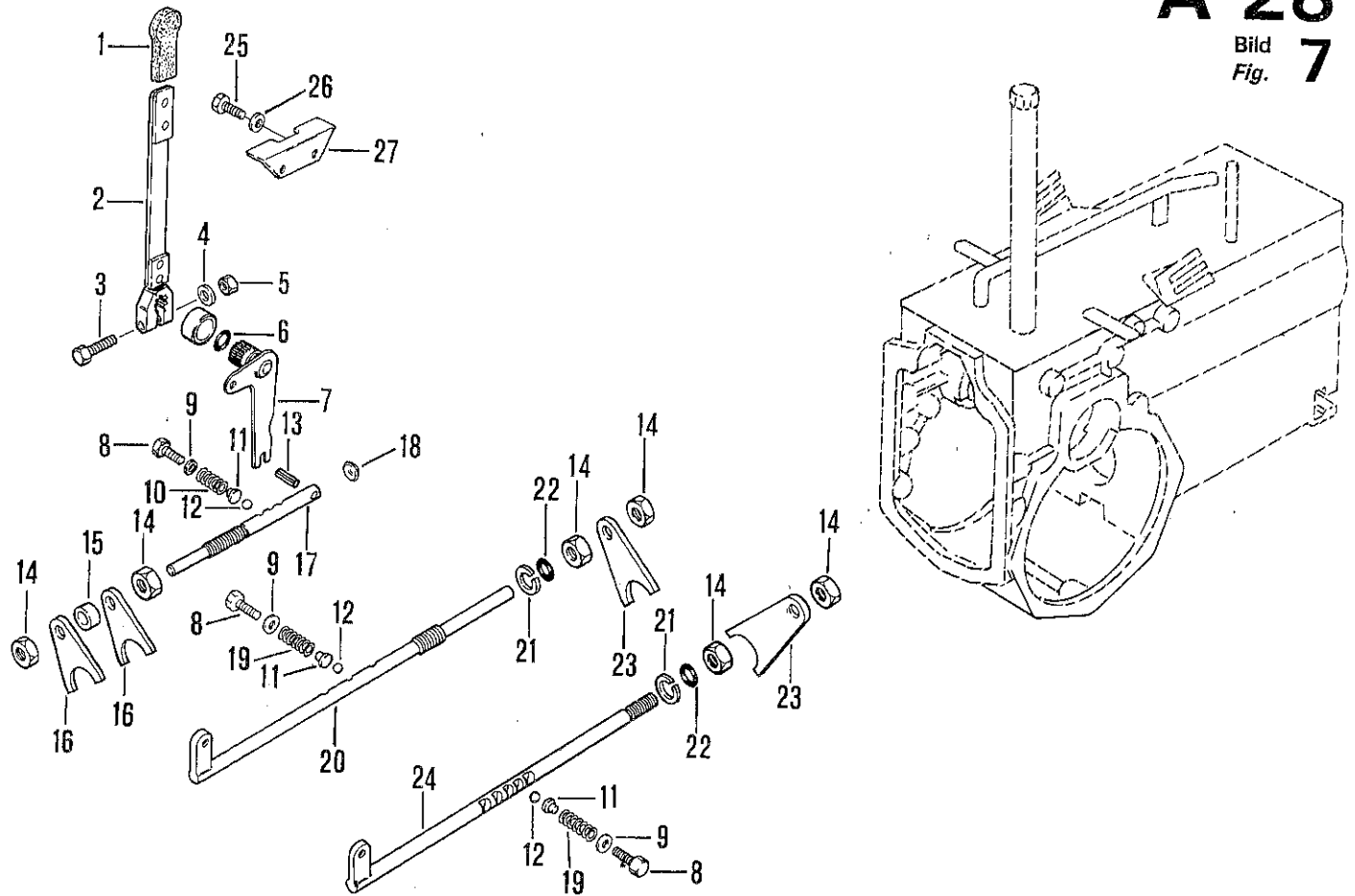

No. pezzo No. pièce No. Bild No. pieza	No. di ordinazione Part No. No. de commande Bestell. - Nr. No. de pedido	No. pezzo No. pièce No. Bild No. pieza	No. di ordinazione Part No. No. de commande Bestell. - Nr. No. de pedido	No. pezzo No. pièce No. Bild No. pieza	No. di ordinazione Part No. No. de commande Bestell. - Nr. No. de pedido
1	82.8471.000	20	19.0006.303		
2	19.0006.351	21	19.0005.261		
3	86.2847.000	22	80.3183.000		
4	84.3643.060	23	19.0005.231		
5	81.4574.000	24	19.0006.301		
6	80.3217.040	25	86.1948.000		
7	19.0005.256	26	84.3570.000		
8	86.3108.050	27	19.0033.884		
9	84.3754.080				
10	83.1014.086				
11	47.1560.048				
12	84.7432.000				
13	85.1333.000				
14	01.0001.319				
15	19.0005.253				
16	19.0005.234				
17	19.0005.252				
18	85.2613.000				
19	83.1020.000				

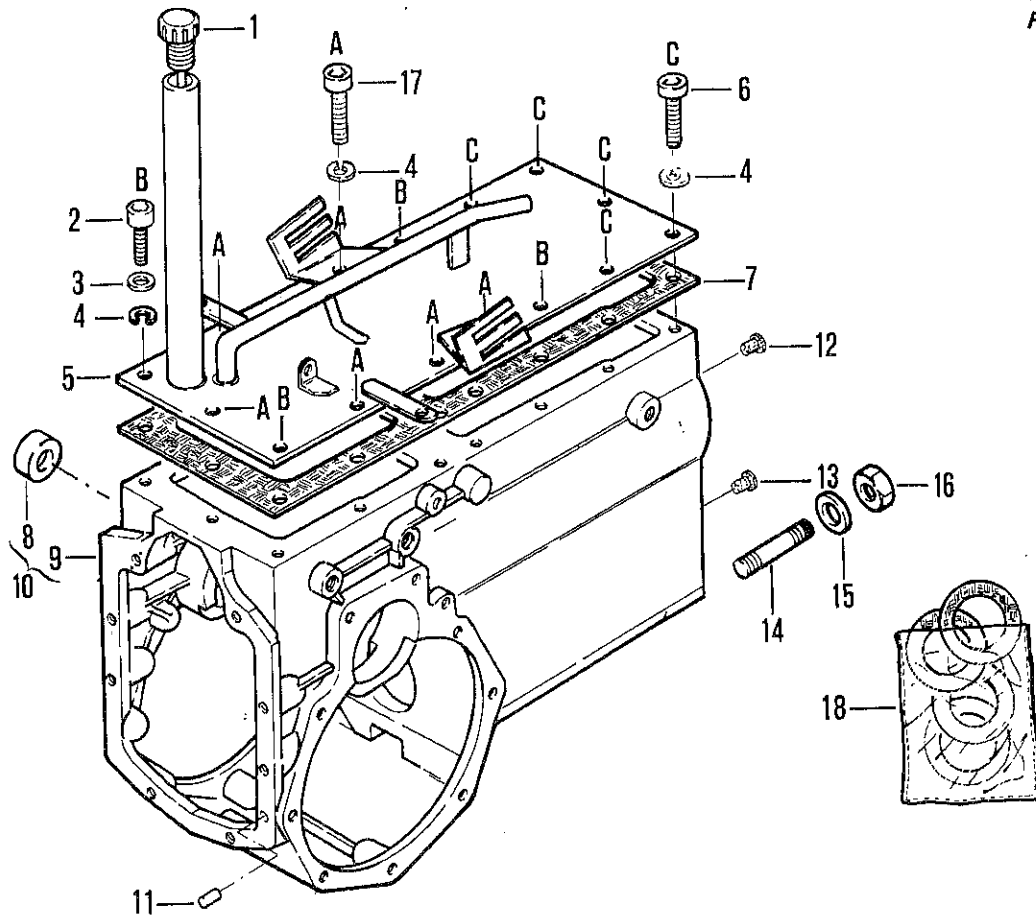

No. pezzo No. piece No. pièce No. Bild No. pieza	No. di ordinazione Part No. No. de commande Bestell. - Nr. No. de pedido	No. pezzo No. piece No. pièce No. Bild No. pieza	No. di ordinazione Part No. No. de commande Bestell. - Nr. No. de pedido	No. pezzo No. piece No. pièce No. Bild No. pieza	No. di ordinazione Part No. No. de commande Bestell. - Nr. No. de pedido
1	85.3513.000				
2	86.3301.000				
3	84.3807.000				
4	84.3755.000				
5	19.0006.355				
6	86.3347.050				
7	25.0010.503				
8	19.0005.255				
9	19.0006.352				
10	19.0006.034				
11	85.1411.000				
12	85.2524.010				
13	85.2516.005				
14	83.8745.000				
15	84.4030.000				
16	81.4787.050				
17	86.3265.000				
18	19.0006.016				

Gultigkeitsvermerk
Usage Code

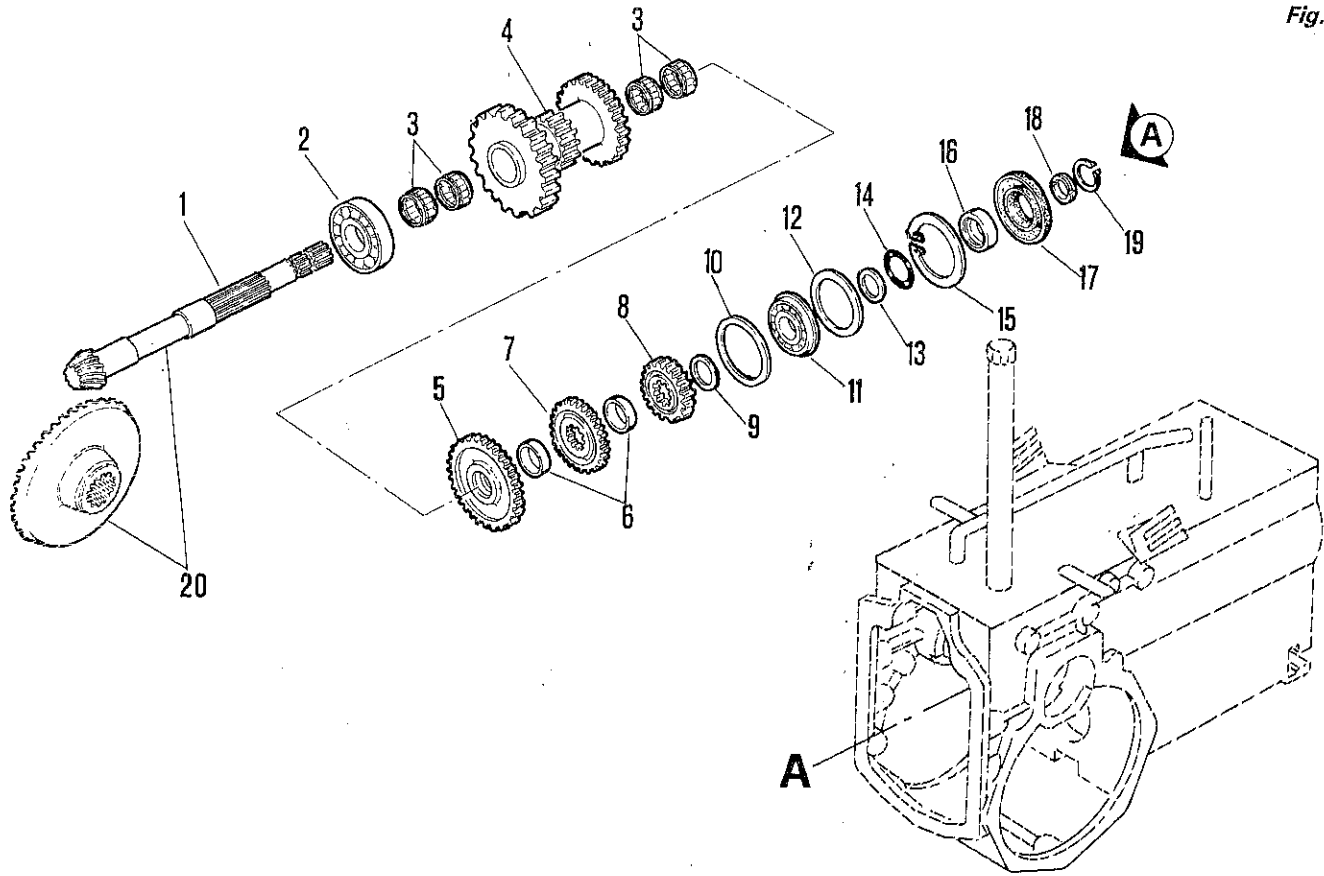

No. pezzo No. pièce No. Bild No. pieza	No. di ordinazione Part No. No. de commande Bestell. - Nr. No. de pedido	No. pezzo No. pièce No. Bild No. pieza	No. di ordinazione Part No. No. de commande Bestell. - Nr. No. de pedido	No. pezzo No. pièce No. Bild No. pieza	No. di ordinazione Part No. No. de commande Bestell. - Nr. No. de pedido
1	19.0005.139	18	19.0005.205		
2	81.2776.000	19	80.1245.000		
3	81.2738.000	20	19.0005.283		
4	19.0005.130				
5	19.0005.121				
6	19.0005.266				
7	19.0005.106				
8	19.0005.232				
9	84.4374.000				
10	85.0130.000 (0,2 mm)				
-	85.0130.010 (0,3 mm)				
11	81.2728.000				
12	19.0005.260				
13	85.0052.020 (0,2 mm)				
-	85.0052.030 (0,3 mm)				
14	80.3205.000				
15	80.1422.000				
16	19.0005.226				
17	80.2188.075				

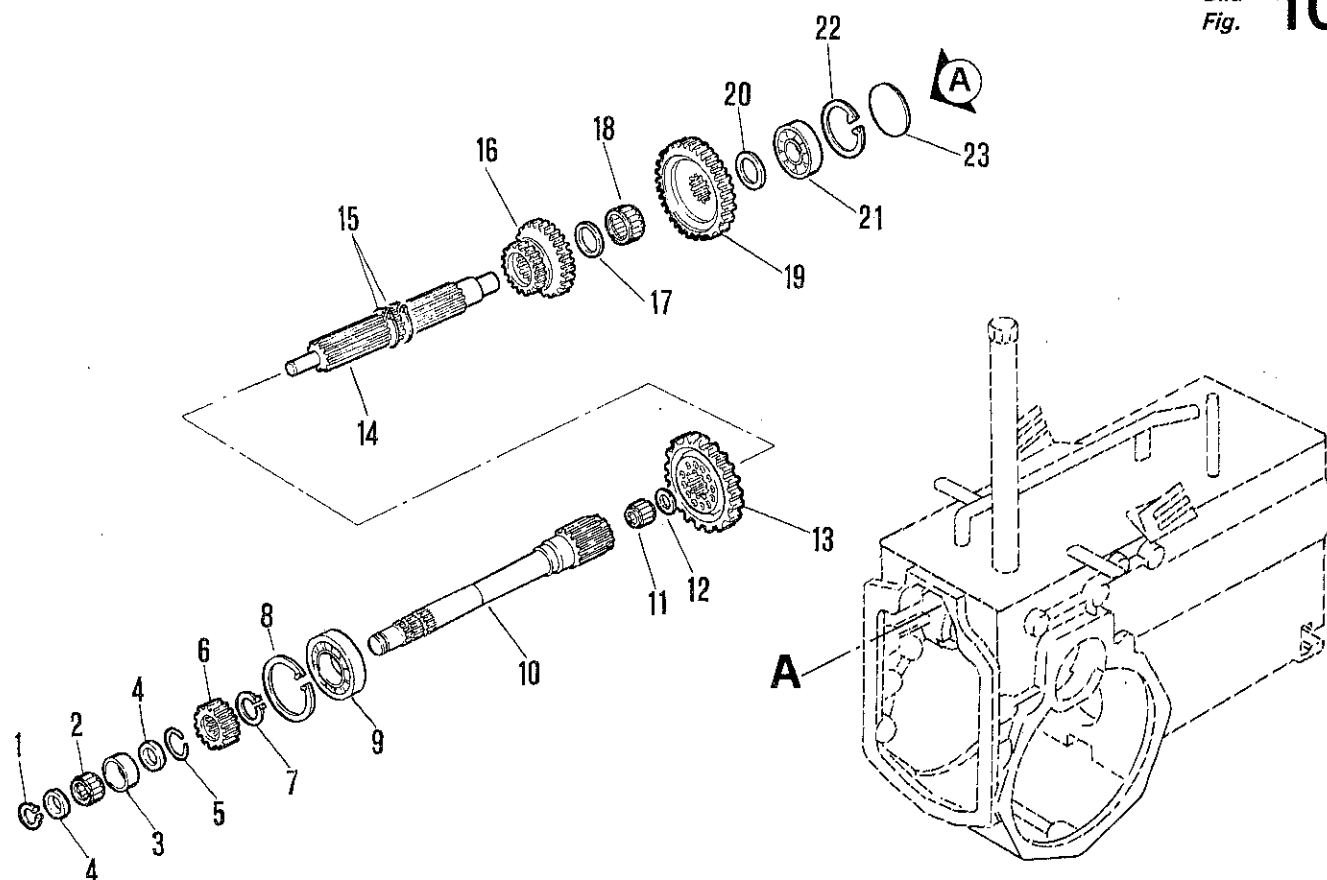

No. pezzo No. piece No. pièce No. Bild No. pieza	No. di ordinazione Part No. No. de commande Bestell. - Nr. No. de pedido	No. pezzo No. piece No. pièce No. Bild No. pieza	No. di ordinazione Part No. No. de commande Bestell. - Nr. No. de pedido	No. pezzo No. piece No. pièce No. Bild No. pieza	No. di ordinazione Part No. No. de commande Bestell. - Nr. No. de pedido
1	80.1149.000	20	84.4241.000		
2	81.2613.000	21	81.2646.000		
3	80.4440.070	22	80.1368.000		
4	19.0006.205	23	85.2766.000		
5	80.0046.100				
6	19.0006.201				
7	80.1174.000				
8	80.1400.000				
9	81.2730.020				
10	19.0006.102				
11	81.2559.050				
12	19.0005.254				
13	19.0005.134				
14	19.0005.251				
15	80.1229.000				
16	19.0005.133				
17	84.4374.000				
18	81.2686.000				
19	19.0005.128				

Gültigkeitsvermerk
Usage Code

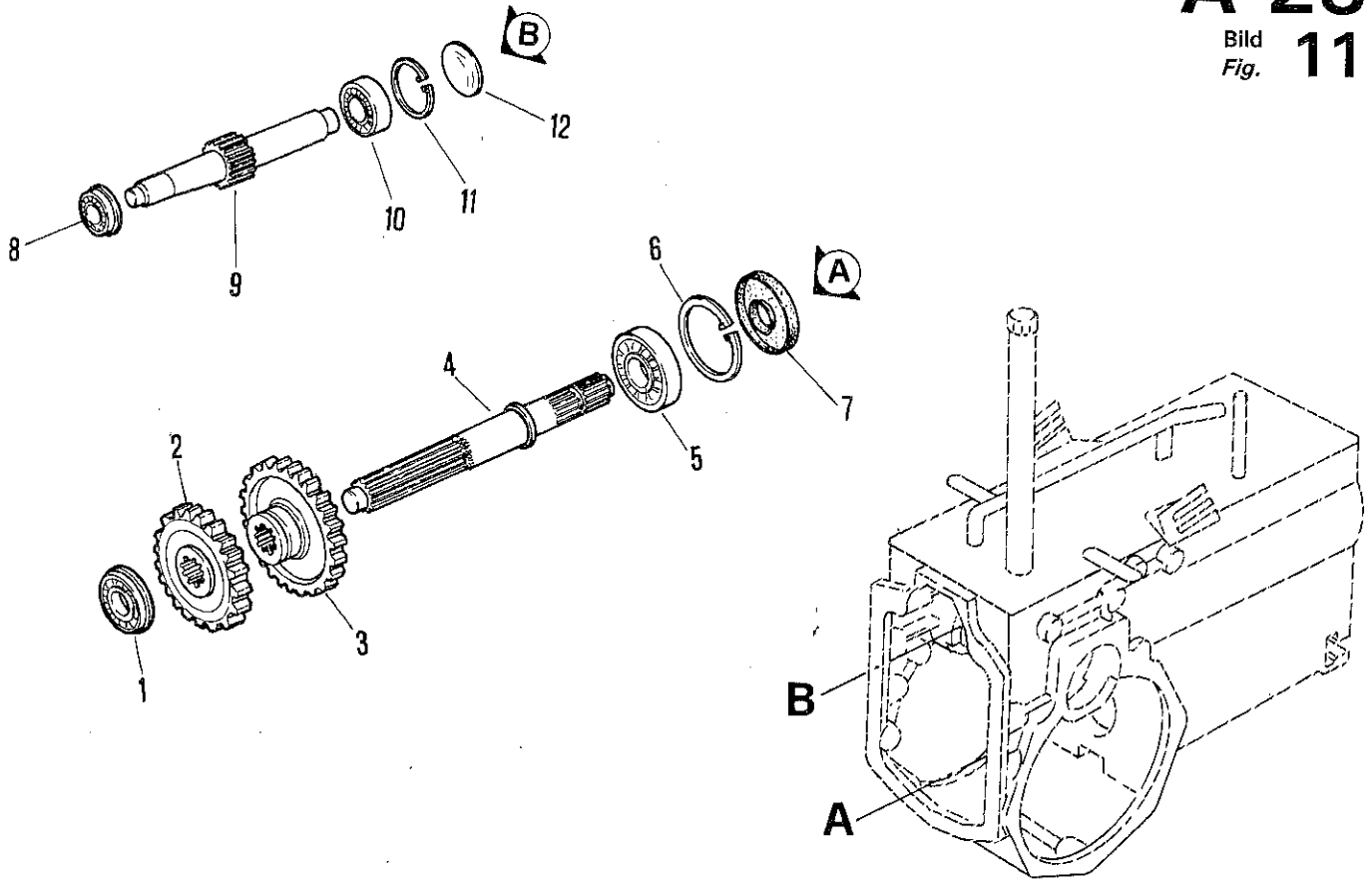

No. pezzo No. pièce No. Bild No. pieza	No. di ordinazione Part No. No. de commande Bestell. - Nr. No. de pedido	No. pezzo No. pièce No. Bild No. pieza	No. di ordinazione Part No. No. de commande Bestell. - Nr. No. de pedido	No. pezzo No. pièce No. Bild No. pieza	No. di ordinazione Part No. No. de commande Bestell. - Nr. No. de pedido
1	81.2728.000				
2	19.0005.132				
3	19.0005.131				
4	19.0005.225				
5	81.2776.000				
6	80.1422.000				
7	80.2127.010				
8	81.2584.000				
9	19.0005.120				
10	81.2707.000				
11	80.1368.000				
12	85.2766.000				

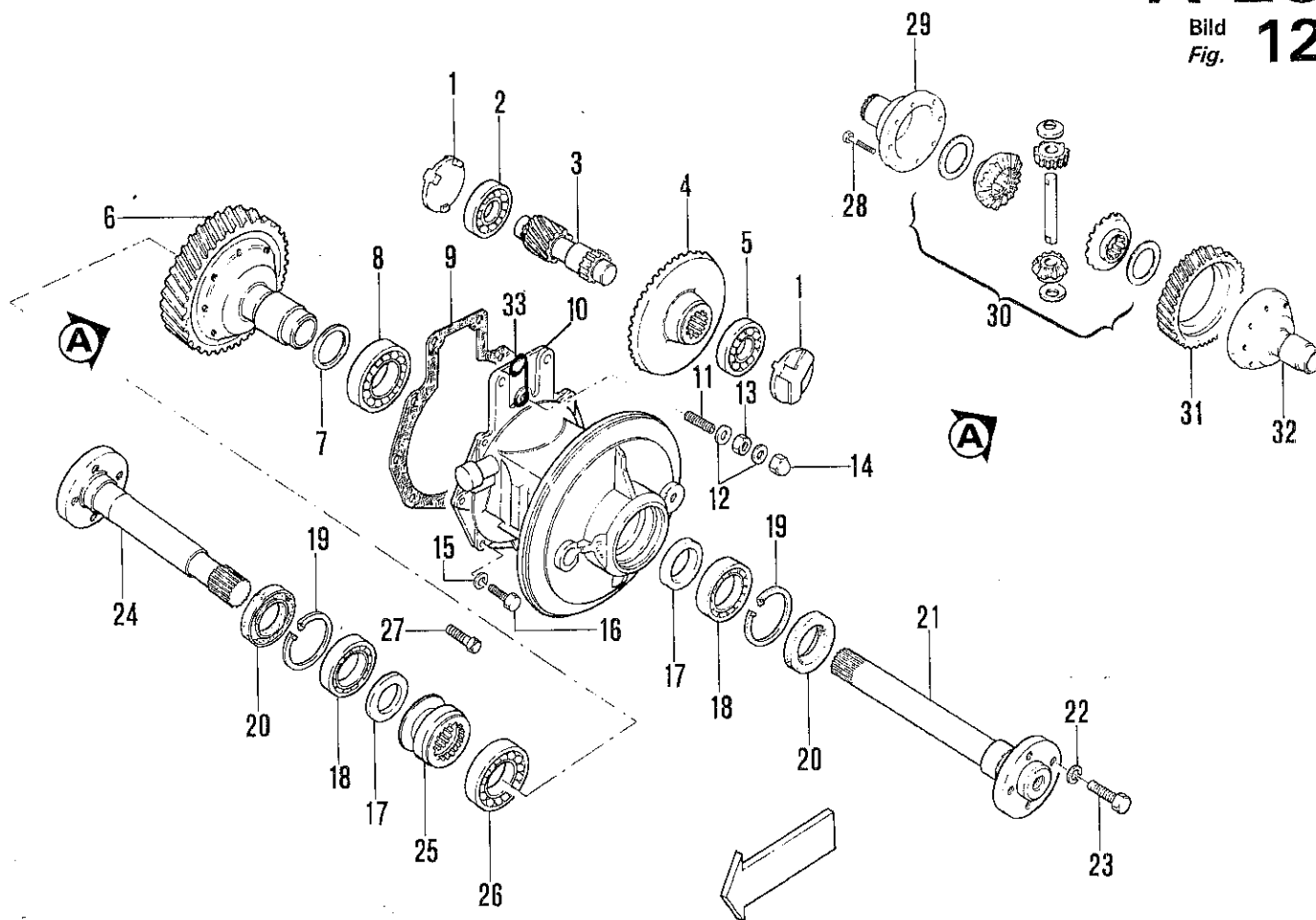

No. pezzo No. piece No. pièce No. Bild No. pieza	No. di ordinazione Part No. No. de commande Bestell. - Nr. No. de pedido	No. pezzo No. piece No. pièce No. Bild No. pieza	No. di ordinazione Part No. No. de commande Bestell. - Nr. No. de pedido	No. pezzo No. piece No. pièce No. Bild No. pieza	No. di ordinazione Part No. No. de commande Bestell. - Nr. No. de pedido
1	19.0010.123	18	81.2898.000		
2	81.2780.000	19	80.1428.000		
3	19.0010.215	20	80.2209.050		
4	19.0010.113	21	19.0011.104		
5	81.2776.000	22	84.3921.030		
6	19.0010.216	23	86.4192.000		
7	85.0113.000 (0,2 mm)	24	19.0011.105		
-	85.0113.020 (0,3 mm)	25	19.0011.113		
8	81.2957.000	26	81.2972.000		
9	19.0010.903	27	86.3429.000		
10	19.0011.015	28	86.3412.070		
-	19.0011.021	29	19.0010.115		
11	86.4216.050	30	19.0011.210		
12	84.3948.000	31	19.0010.114		
13	81.4746.000	32	19.0010.017		
14	81.4761.050	33	16.0015.203		
15	84.3755.000				
16	86.3328.000				
17	09.0010.202				

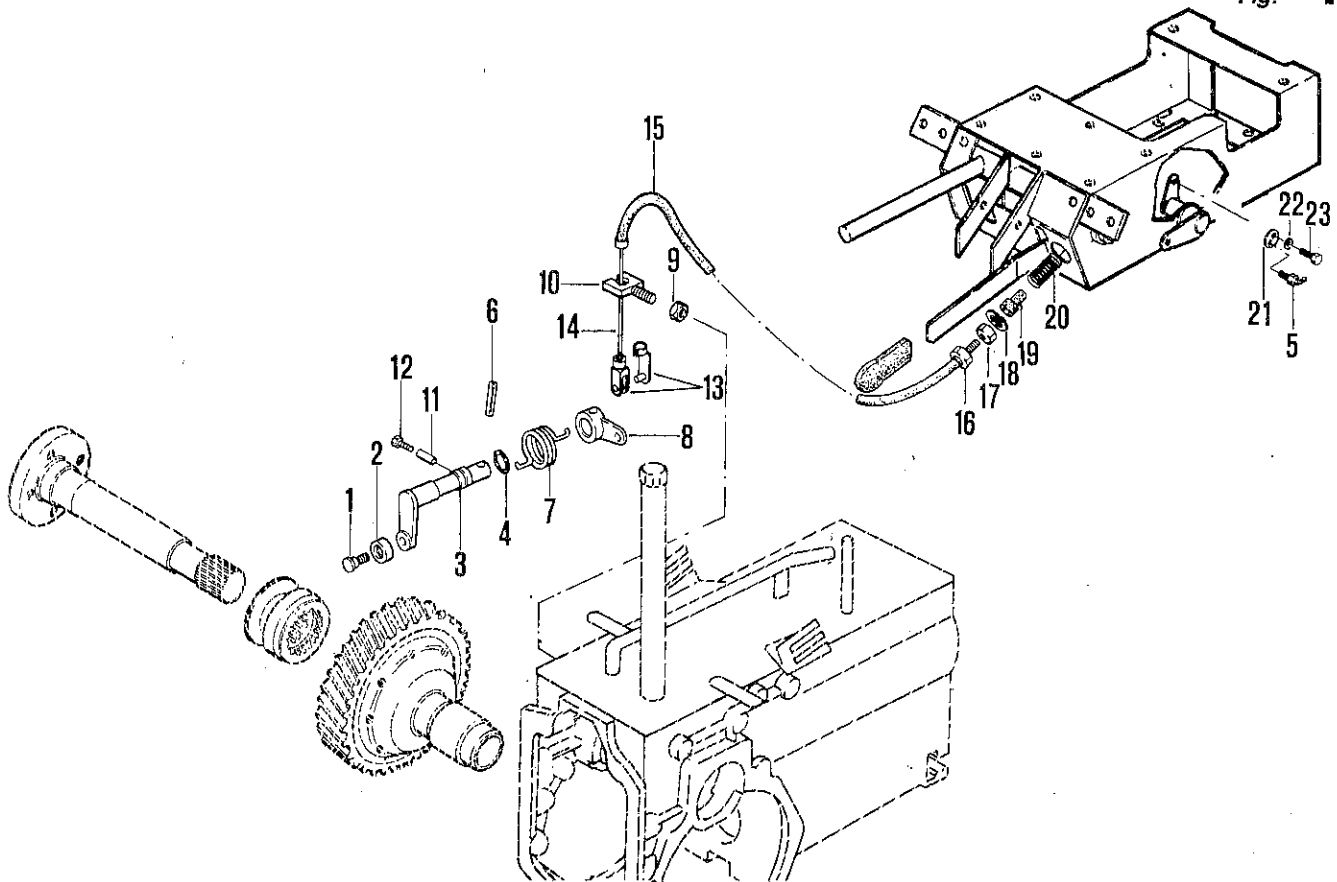

No. pezzo No. pièce No. pièce No. Bild No. pieza	No. di ordinazione Part No. No. de commande Bestell. - Nr. No. de pedido	No. pezzo No. pièce No. pièce No. Bild No. pieza	No. di ordinazione Part No. No. de commande Bestell. - Nr. No. de pedido	No. pezzo No. pièce No. pièce No. Bild No. pieza	No. di ordinazione Part No. No. de commande Bestell. - Nr. No. de pedido
1	01.0001.078	20	83.1221.000		
2	01.0001.079	21	19.0031.265		
3	19.0011.114	22	84.3570.000		
4	80.3179.000	23	86.2097.010		
5	82.6018.000				
6	85.1190.010				
7	19.0011.901				
8	11.0011.209				
9	81.4627.000				
10	19.0025.208				
11	85.1318.000				
12	19.0011.223				
13	86.0030.000				
14	86.6331.000				
15	85.7276.090				
16	85.8026.000				
17	81.4624.000				
18	80.1156.000				
19	16.0032.240				

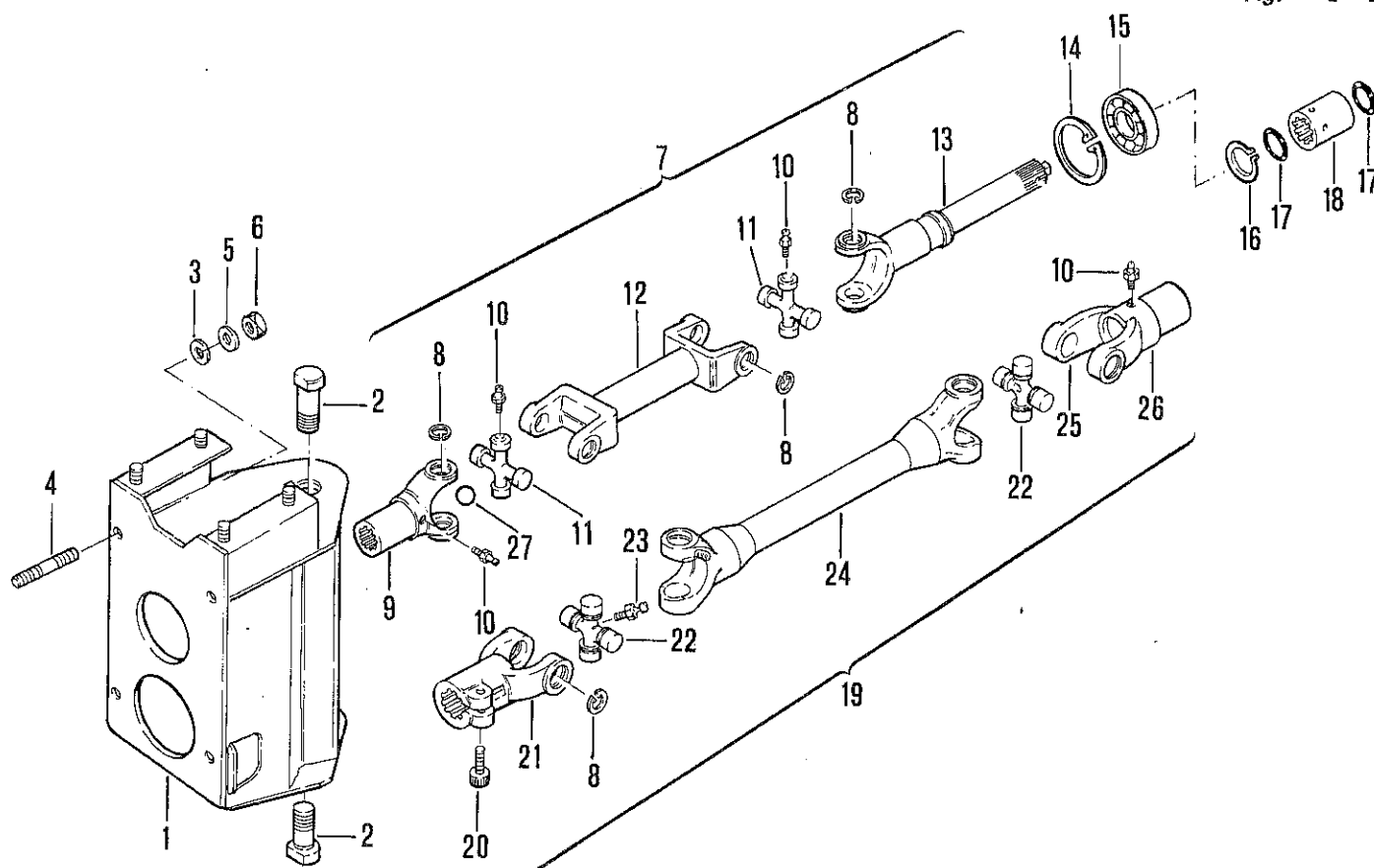

No. pezzo No. pièce No. pièce No. Bild No. pieza	No. di ordinazione Part No. No. de commande Bestell. - Nr. No. de pedido	No. pezzo No. pièce No. pièce No. Bild No. pieza	No. di ordinazione Part No. No. de commande Bestell. - Nr. No. de pedido	No. pezzo No. pièce No. pièce No. Bild No. pieza	No. di ordinazione Part No. No. de commande Bestell. - Nr. No. de pedido
1	19.0012.468	20	86.3881.000		
2	19.0012.100	21	19.0012.288		
3	84.4084.000	22	19.0012.289		
4	83.8745.000	23	82.6016.000		
5	84.4030.000	24	19.0012.290		
6	81.4787.050	25	19.0012.384		
7	19.0012.358	26	19.0012.291		
8	80.1163.000	27	19.0012.383		
9	19.0012.292				
10	82.6016.000				
11	19.0012.293				
12	19.0012.294				
13	19.0012.359				
14	80.1400.000				
15	81.2752.000				
16	80.1241.000				
17	80.3195.000				
18	19.0012.414				
19	19.0012.255				

Gültigkeitsvermerk
Usage Code

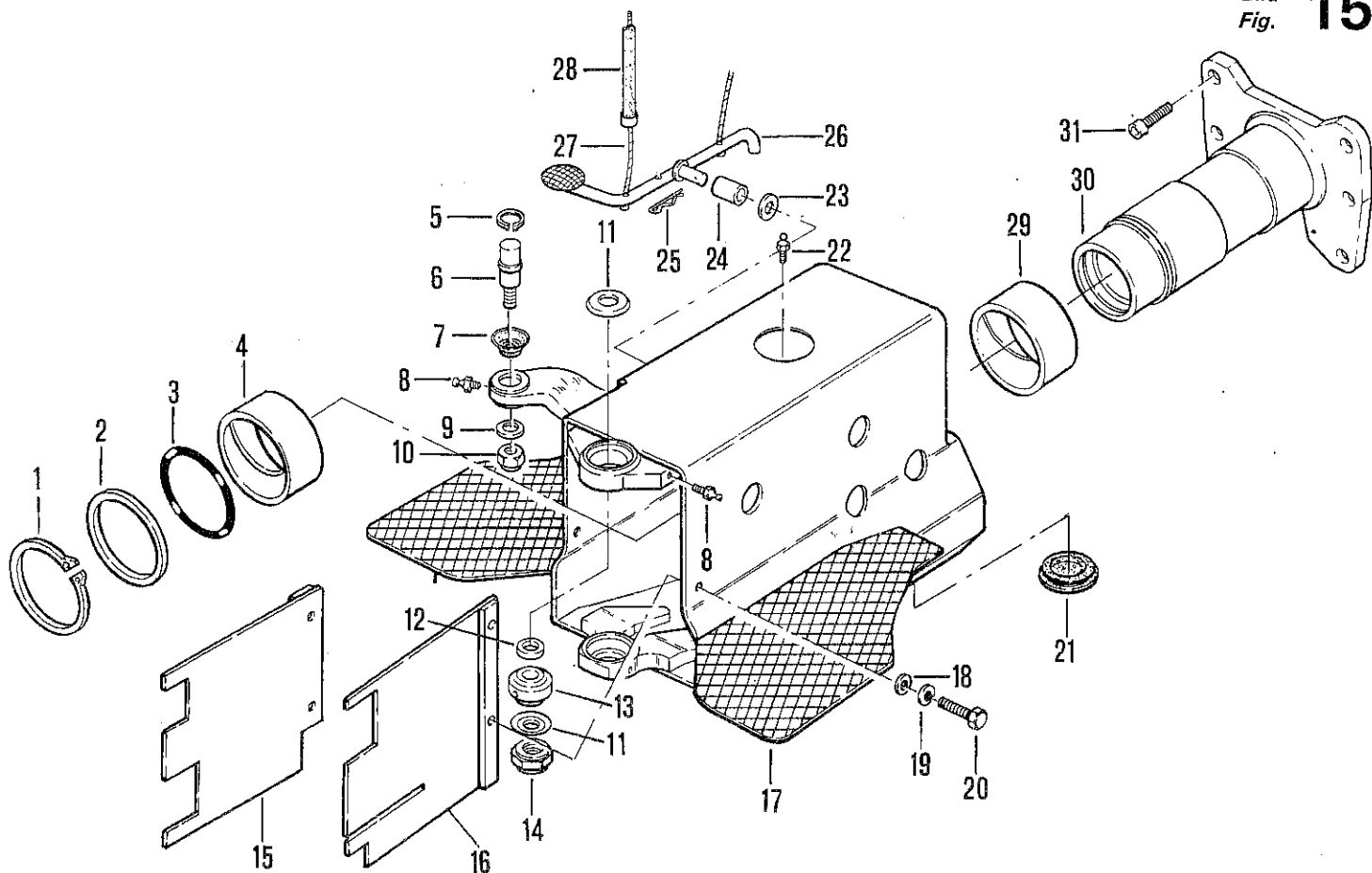

No. pezzo No. pièce No. pièce No. Bild No. pieza	No. di ordinazione Part No. No. de commande Bestell. - Nr. No. de pedido	No. pezzo No. pièce No. pièce No. Bild No. pieza	No. di ordinazione Part No. No. de commande Bestell. - Nr. No. de pedido	No. pezzo No. pièce No. pièce No. Bild No. pieza	No. di ordinazione Part No. No. de commande Bestell. - Nr. No. de pedido
1	80.1425.050	18	84.3577.010		
2	19.0012.232	19	84.3561.000		
3	80.3339.050	20	86.1934.060		
4	19.0012.226	21	85.3521.050		
5	80.1160.000	22	82.6038.000		
6	11.0030.226	23	84.3993.000		
7	81.1955.000	24	80.4051.000		
8	82.6016.000	25	81.0617.050		
9	84.3927.050	26	19.0012.473		
10	81.4765.000	27	85.6154.010		
11	19.0012.234	28	85.7005.020		
12	19.0012.233 (6,5 mm)	29	19.0012.312		
-	19.0012.388 (6 mm)	30	19.0012.015		
-	19.0012.389 (5,5 mm)	31	86.4203.050		
13	81.1957.000				
14	81.4908.000				
15	19.0012.474				
16	19.0012.475				
17	19.0012.467				

Gultigkeitsvermerk
Usage Code

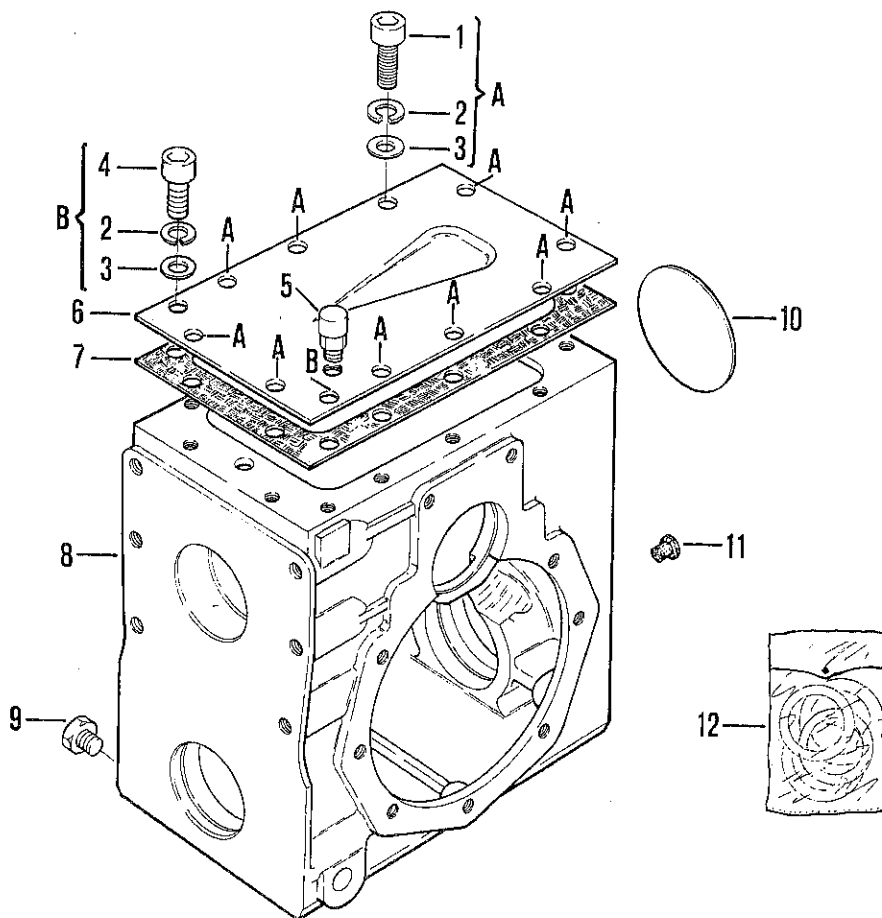

No. pezzo No. piece No. pièce No. Bild No. pieza	No. di ordinazione Part No. No. de commande Bestell. - Nr. No. de pedido	No. pezzo No. piece No. pièce No. Bild No. pieza	No. di ordinazione Part No. No. de commande Bestell. - Nr. No. de pedido	No. pezzo No. piece No. pièce No. Bild No. pieza	No. di ordinazione Part No. No. de commande Bestell. - Nr. No. de pedido
1	86.3302.050				
2	84.3775.050				
3	84.3815.000				
4	86.3266.050				
5	85.2540.030				
6	19.0008.204				
7	25.0010.503				
8	19.0008.013				
9	85.2628.000				
10	85.2798.000				
11	85.2516.005				
12	19.0008.016				

Gultigkeitsvermerk
Usage Code

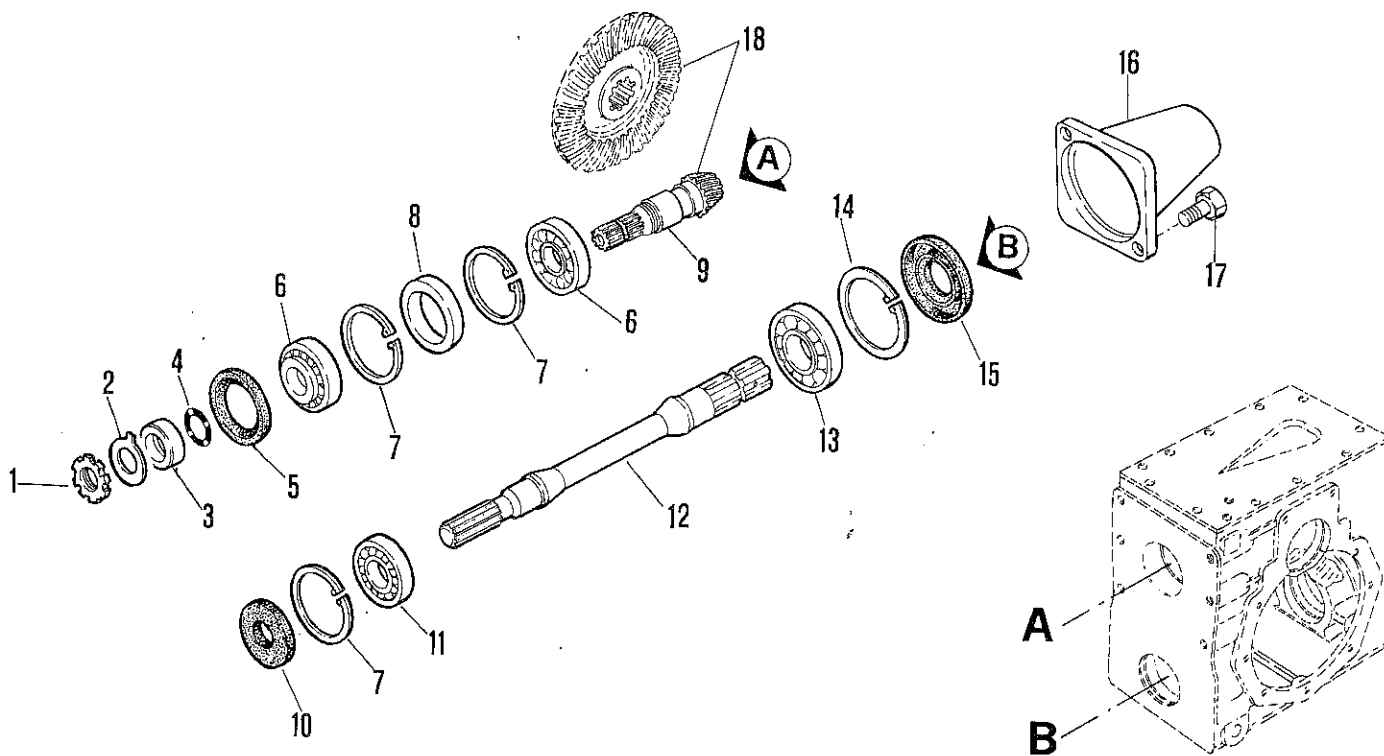

No. pezzo No. pièce No. pièce No. Bild No. pieza	No. di ordinazione Part No. No. de commande Bestell. - Nr. No. de pedido	No. pezzo No. pièce No. pièce No. Bild No. pieza	No. di ordinazione Part No. No. de commande Bestell. - Nr. No. de pedido	No. pezzo No. pièce No. pièce No. Bild No. pieza	No. di ordinazione Part No. No. de commande Bestell. - Nr. No. de pedido
1	82.1035.000				
2	84.4447.000				
3	11.0005.299				
4	80.3207.000				
5	80.2198.000				
6	81.2755.000				
7	80.1400.000				
8	19.0008.203				
9	19.0008.102				
10	80.2125.050				
11	81.2749.000				
12	19.0008.202				
13	81.2846.000				
14	80.1422.000				
15	80.2162.000				
16	11.0032.373				
17	86.3703.000				
18	19.0008.218				

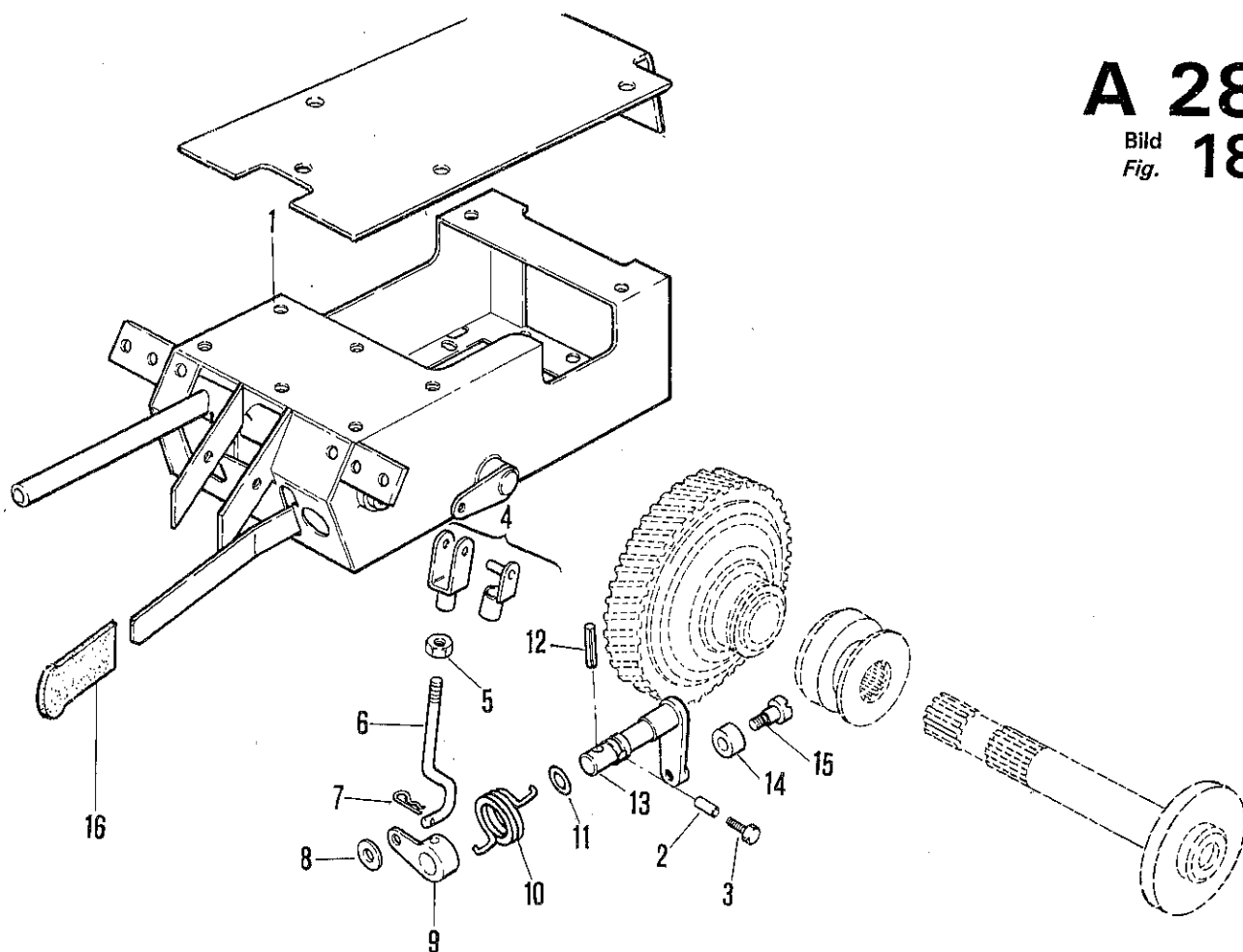

No. pezzo No. piece No. pièce No. Bild No. pieza	No. di ordinazione Part No. No. de commande Bestell. - Nr. No. de pedido	No. pezzo No. piece No. pièce No. Bild No. pieza	No. di ordinazione Part No. No. de commande Bestell. - Nr. No. de pedido	No. pezzo No. piece No. pièce No. Bild No. pieza	No. di ordinazione Part No. No. de commande Bestell. - Nr. No. de pedido
1	19.0031.311				
2	85.1318.000				
3	19.0011.223				
4	86.0058.000				
5	81.4580.000				
6	19.0011.110				
7	85.1355.000				
8	84.3685.000				
9	19.0011.107				
10	19.0011.901				
11	80.3179.000				
12	85.1190.010				
13	19.0011.114				
14	01.0001.079				
15	01.0001.078				
16	82.8471.010				

Gültigkeitsvermerk
Usage Code

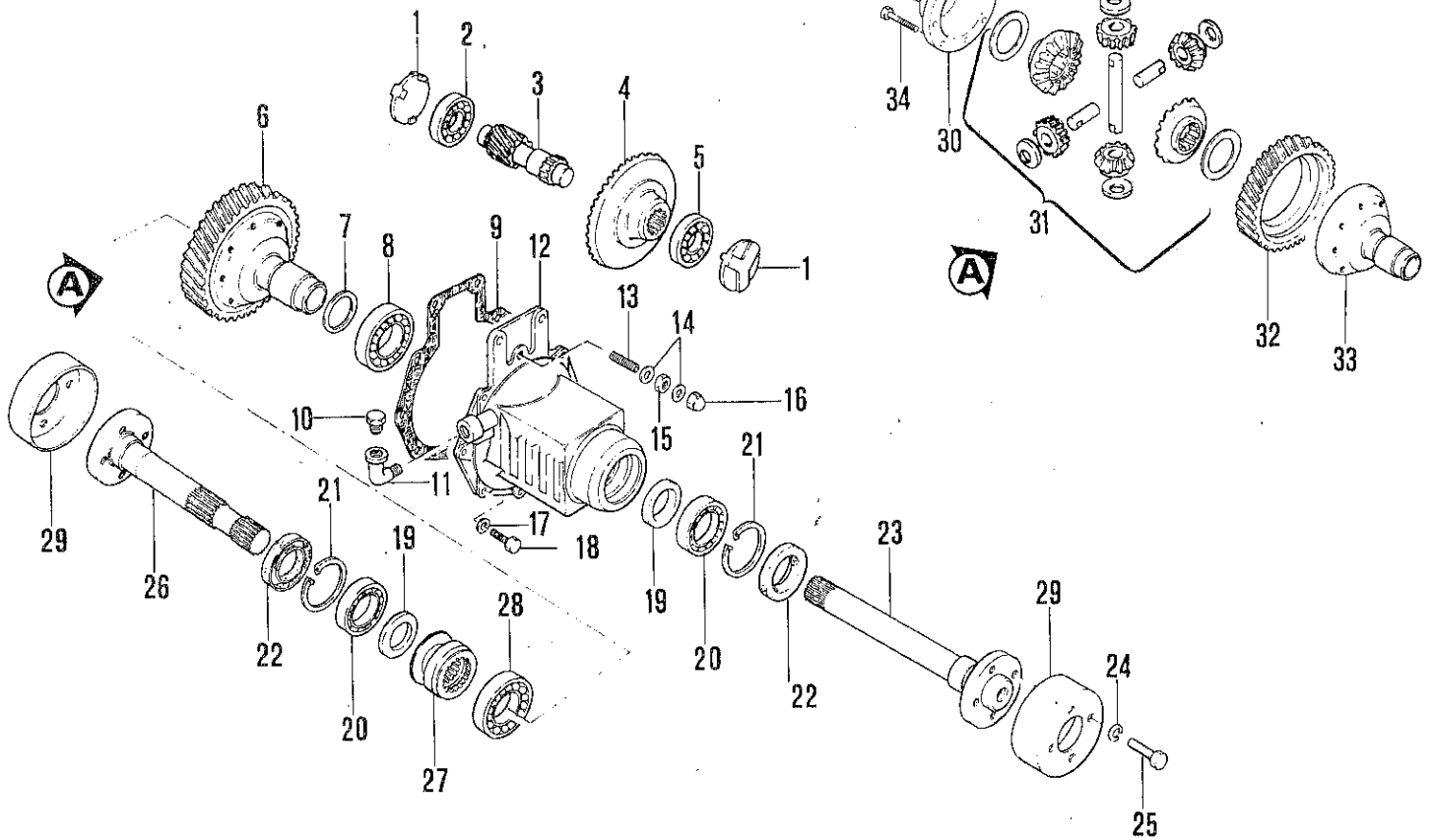

No. pezzo No. piece No. pièce No. Bild No. pieza	No. di ordinazione Part No. No. de commande Bestell. - Nr. No. de pedido	No. pezzo No. piece No. pièce No. Bild No. pieza	No. di ordinazione Part No. No. de commande Bestell. - Nr. No. de pedido	No. pezzo No. piece No. pièce No. Bild No. pieza	No. di ordinazione Part No. No. de commande Bestell. - Nr. No. de pedido
1	19.0010.123	18	86.3328.000		
2	81.2780.000	19	09.0010.202		
3	19.0010.217	20	81.2898.000		
4	19.0011.103	21	80.1428.000		
5	81.2781.000	22	80.2209.050		
6	19.0011.207	23	19.0011.104		
7	85.0113.000 (0,2 mm)	24	84.3921.030		
-	85.0113.020 (0,3 mm)	25	86.4192.000		
8	81.2957.000	26	19.0011.105		
9	19.0010.903	27	19.0011.113		
10	85.2628.000	28	81.2973.000		
11	84.0544.000	29	11.0011.251		
12	19.0011.017 ↘	30	19.0010.115		
-	19.0011.018 ↘	31	19.0011.211		
13	86.4216.050	32	19.0010.121		
14	84.3948.000	33	19.0010.017		
15	81.4746.000	34	86.3412.070		
16	81.4761.050				
17	84.3755.000				

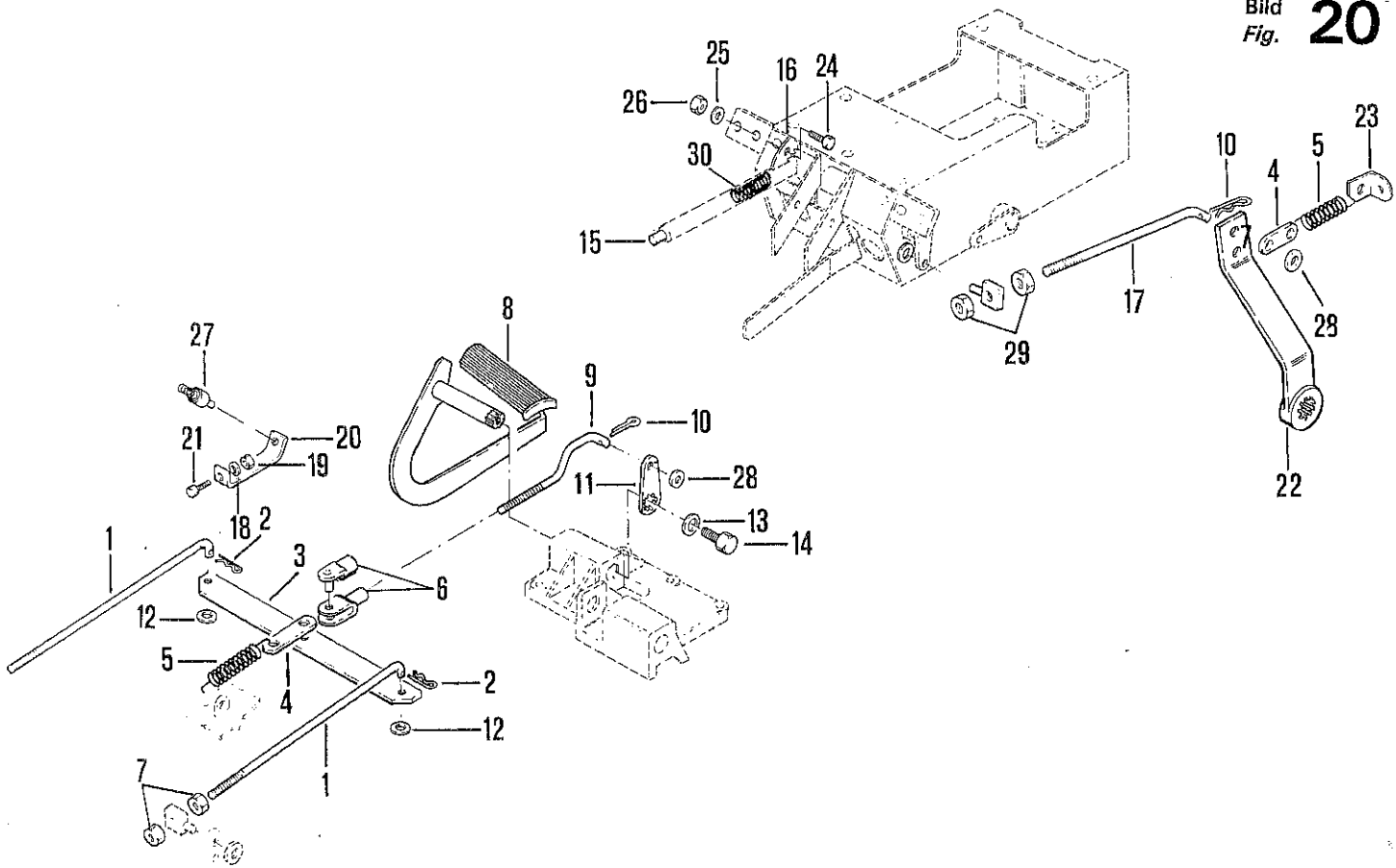

No. pezzo No. piece No. pièce No. Bild No. pieza	No. di ordinazione Part No. No. de commande Bestell. - Nr. No. de pedido	No. pezzo No. piece No. pièce No. Bild No. pieza	No. di ordinazione Part No. No. de commande Bestell. - Nr. No. de pedido	No. pezzo No. piece No. pièce No. Bild No. pieza	No. di ordinazione Part No. No. de commande Bestell. - Nr. No. de pedido
1	19.0021.202	20	19.0033.284		
2	81.0505.000	21	86.2488.000		
3	19.0021.203	22	11.0021.101		
4	19.0021.213	23	11.0015.204		
5	83.1139.000	24	86.1933.010		
6	86.0091.000	25	84.3561.000		
7	81.4580.000	26	81.4525.000		
8	19.0033.878	27	82.5488.000		
9	19.0021.205	28	84.3807.000		
10	81.0505.000	29	81.4644.000		
11	19.0033.898	30	83.1109.040		
12	84.3685.000				
13	84.3818.000				
14	86.3149.000				
15	19.0022.215				
16	19.0021.211				
17	19.0021.216				
18	84.3643.060				
19	81.4574.000				

Gültigkeitsvermerk
Usage Code

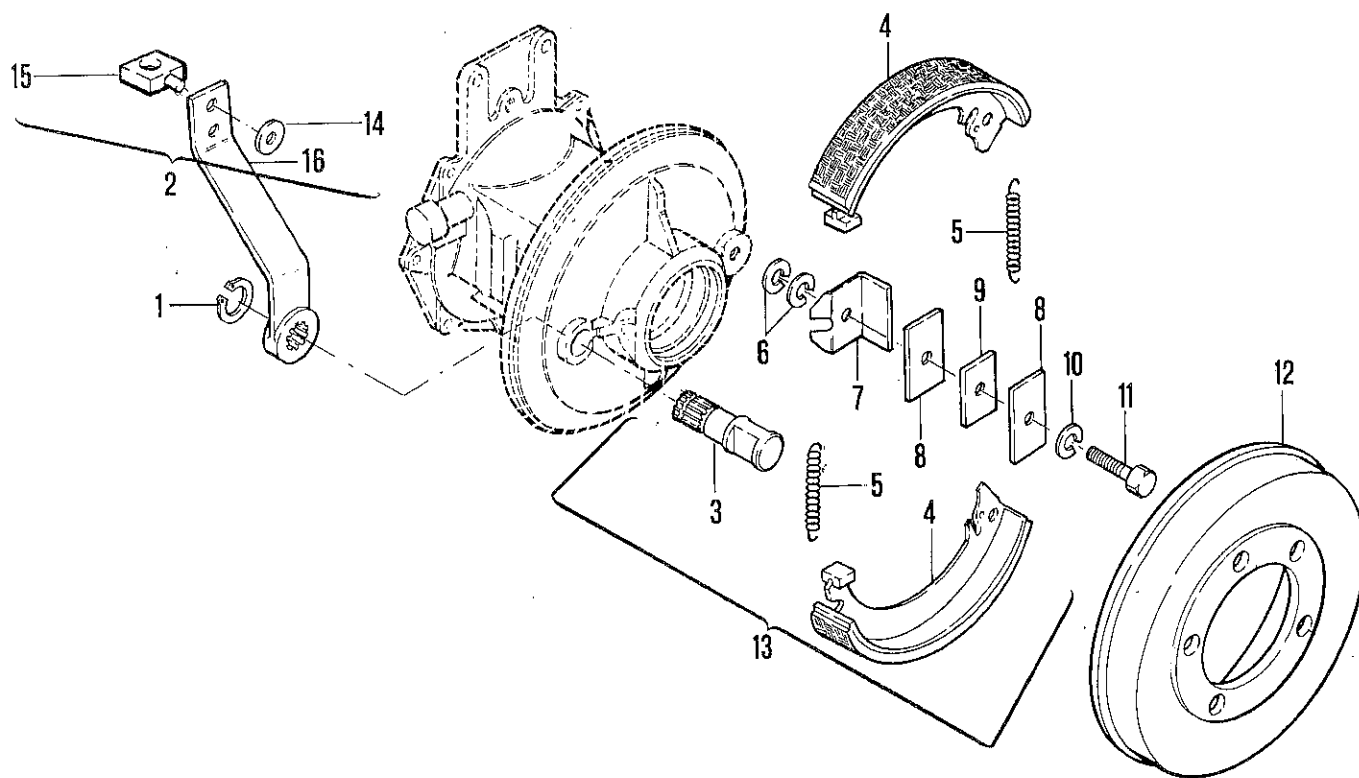

No. pezzo No. pièce No. pièce No. Bild No. pieza	No. di ordinazione Part No. No. de commande Bestell. - Nr. No. de pedido	No. pezzo No. pièce No. pièce No. Bild No. pieza	No. di ordinazione Part No. No. de commande Bestell. - Nr. No. de pedido	No. pezzo No. pièce No. pièce No. Bild No. pieza	No. di ordinazione Part No. No. de commande Bestell. - Nr. No. de pedido
1	80.1155.000				
2	19.0021.225				
—	11.0021.254				
3	19.0021.200				
4	82.3671.000				
5	82.3170.040				
6	84.3992.000				
7	82.3170.010				
8	82.3170.030				
9	82.3170.020				
10	84.3921.020				
11	86.4243.000				
12	82.3870.010				
13	82.3245010				
14	84.3800.000				
15	01.0001.502				
16	11.0021.101				

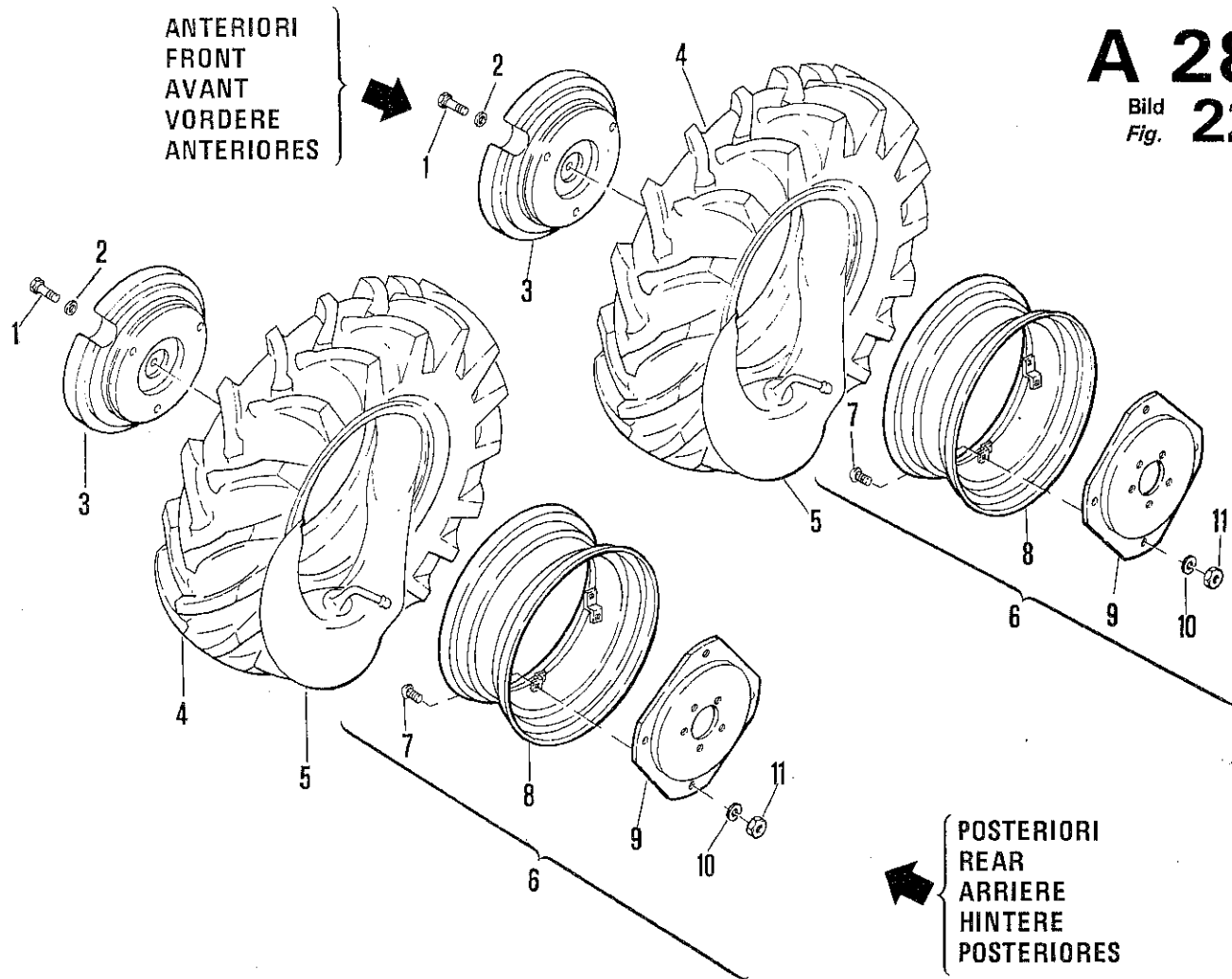

No. pezzo No. piece No. pièce No. Bild No. pieza	No. di ordinazione Part No. No. de commande Bestell. - Nr. No. de pedido	No. pezzo No. piece No. pièce No. Bild No. pieza	No. di ordinazione Part No. No. de commande Bestell. - Nr. No. de pedido	No. pezzo No. piece No. pièce No. Bild No. pieza	No. di ordinazione Part No. No. de commande Bestell. - Nr. No. de pedido
1	86.4351.000 (50 mm) *				
-	86.4377.000 (70 mm) *				
-	86.4392.000 (100 mm) *				
-	86.4403.000 (150 mm) *				
-	86.4406.000 (180 mm) *				
2	84.4084.000 *				
3	19.0011.030 *				
4	84.8635.000				
5	84.8887.000				
6	84.9101.000				
7	86.4177.000				
8	11.0011.910				
9	11.0011.911				
10	84.3921.020				
11	81.4750.000				

* A R.

Gültigkeitsvermerk
Usage Code

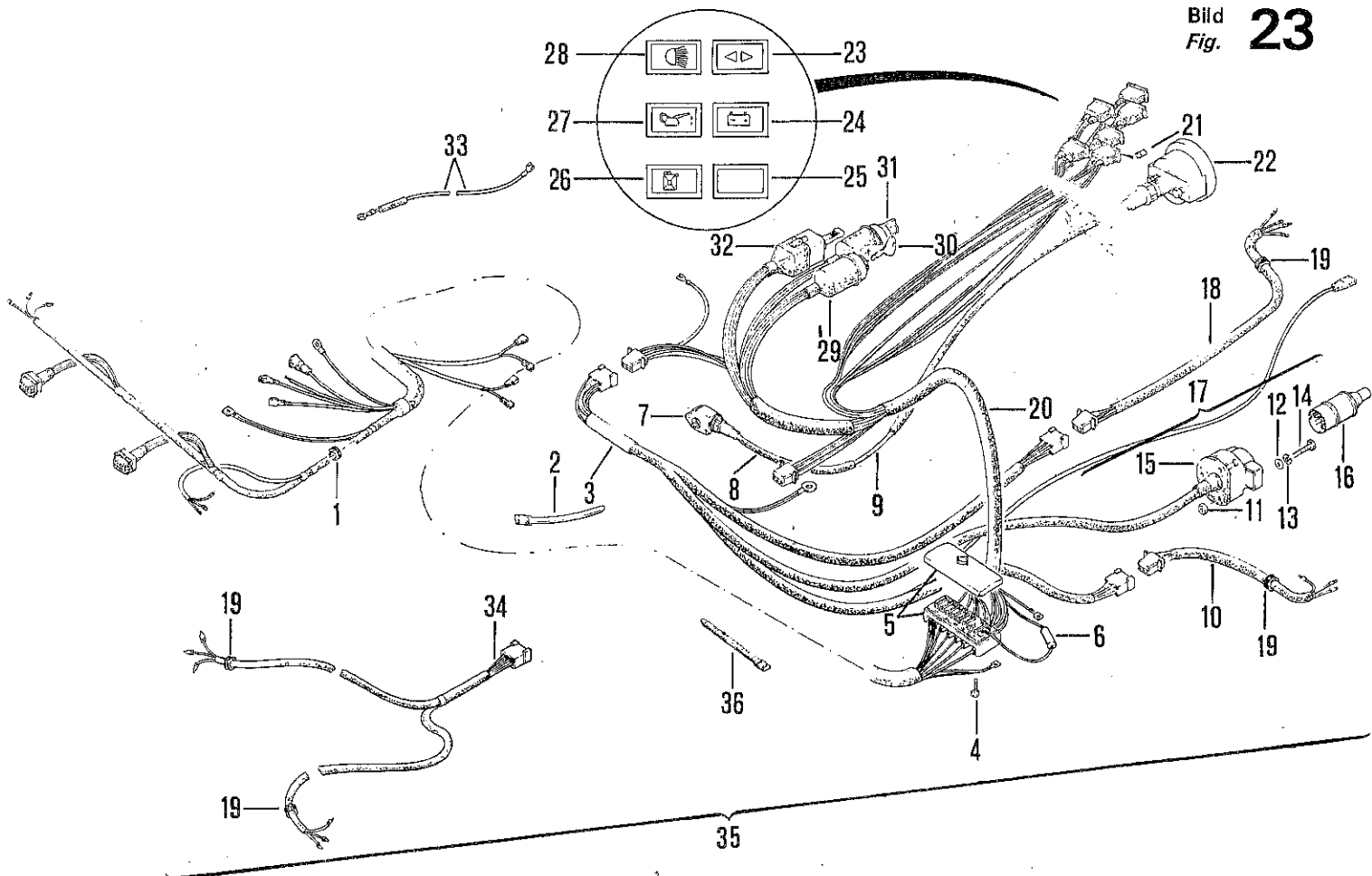

No. pezzo No. piece No. pièce No. Bild No. pieza	No. di ordinazione Part No. No. de commande Bestell. - Nr. No. de pedido	No. pezzo No. piece No. pièce No. Bild No. pieza	No. di ordinazione Part No. No. de commande Bestell. - Nr. No. de pedido	No. pezzo No. piece No. pièce No. Bild No. pieza	No. di ordinazione Part No. No. de commande Bestell. - Nr. No. de pedido
1	82.5416.000	20	19.0018.901		
2	81.7640.000	21	82.5426.000		
3	19.0018.902	22	82.5322.010		
4	86.1935.060	23	82.5436.130		
5	82.5453.000	24	82.5436.140		
6	82.5453.050	25	82.5436.120		
7	82.5322.070	26	82.5436.100		
8	82.5322.060	27	82.5436.110		
9	82.5320.020	28	82.5436.150		
10	19.0018.904	29	82.5400.000		
11	81.4525.000	30	82.5452.020		
12	84.3561.000	31	82.5401.000		
13	84.3542.000	32	82.5436.000		
14	86.1941.000	33	82.5457.000		
15	82.5438.000	34	19.0018.917		
16	82.5451.000	35	19.0018.918		
17	82.5461.000	36	81.7660.000		
18	19.0018.903	Sche			
19	82.5414.000				

Gultigkeitsvermerk
Usage Code

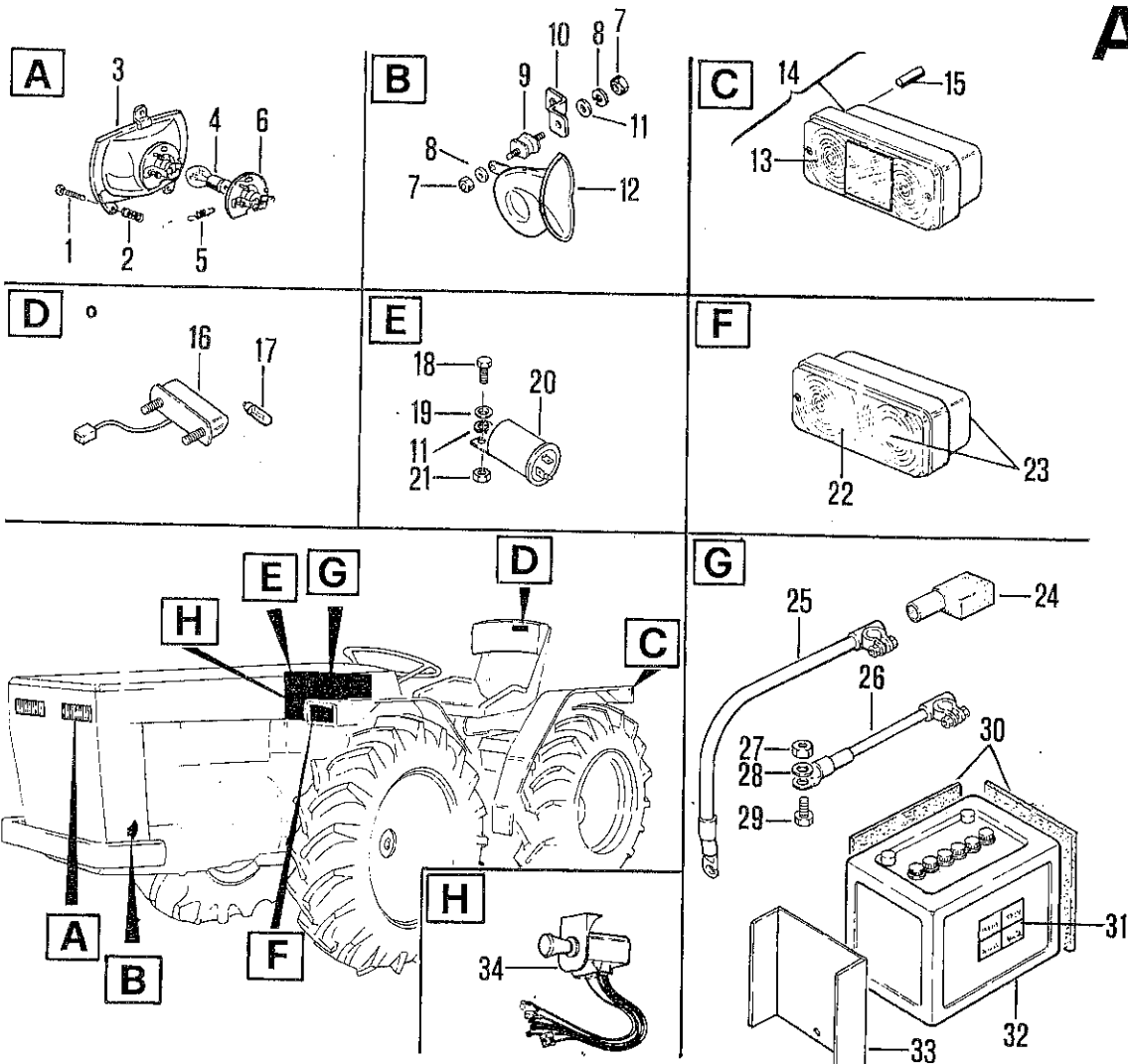

No. pezzo No. pièce No. pièce No. Bild No. pieza	No. di ordinazione Part No. No. de commande Bestell. - Nr. No. de pedido	No. pezzo No. pièce No. pièce No. Bild No. pieza	No. di ordinazione Part No. No. de commande Bestell. - Nr. No. de pedido	No. pezzo No. pièce No. pièce No. Bild No. pieza	No. di ordinazione Part No. No. de commande Bestell. - Nr. No. de pedido
1	DIN7985 M4x25	19	84.3619.000		
2	000.992.36.02	20	82.5139.000		
3	6060.180.01.62	21	81.4546.000		
4	DIN72601-12V	22	82.5420.560		
5	9KD.065.353-00	23	82.5420.500		
6	9FF.066.070-00		82.5420.550		
7	81.4546.000	24	82.5407.030		
8	84.3619.000	25	19.0018.906		
9	84.9206.010	26	82.5445.000		
10	11.0017.978	27	81.4581.000		
11	84.3570.000	28	84.3685.000		
12	82.5417.000	29	86.2555.000		
13	82.5420.660	30	19.0018.908		
14	82.5420.650	31	85.4001.020		
	82.5420.600	32	82.5468.000		
15	19.0018.202	33	19.0018.200		
16	82.5411.000	34	82.5431.000		
17	82.5412.000				
18	86.2097.000				

Gültigkeitsvermerk
Usage Code

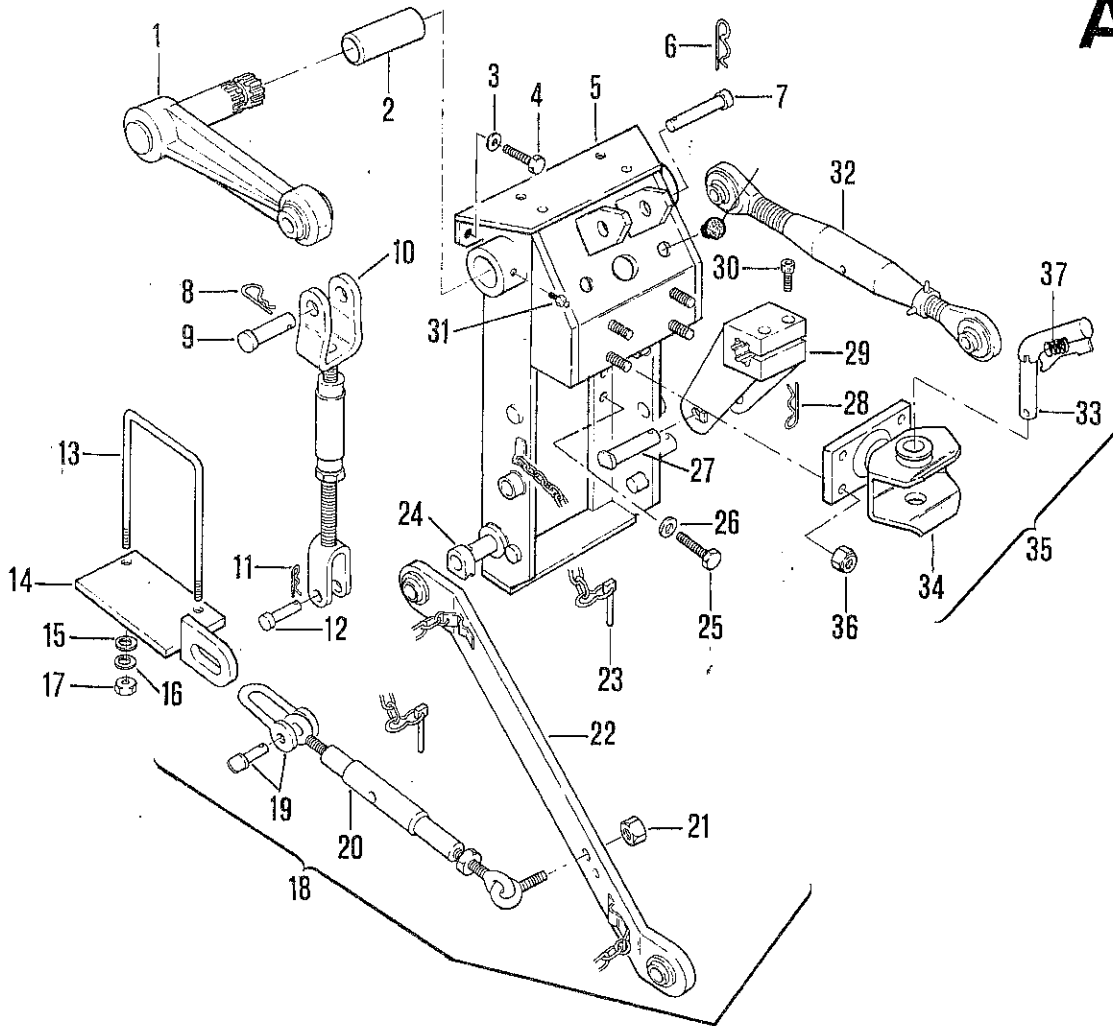

No. pezzo No. pièce No. pièce No. Bild No. pieza	No. di ordinazione Part No. No. de commande Bestell. - Nr. No. de pedido	No. pezzo No. pièce No. pièce No. Bild No. pieza	No. di ordinazione Part No. No. de commande Bestell. - Nr. No. de pedido	No. pezzo No. pièce No. pièce No. Bild No. pieza	No. di ordinazione Part No. No. de commande Bestell. - Nr. No. de pedido
1	19.0031.249	19	80.5860.000	37	000.992.02.76(R)
2	80.4466.000	20	19.0031.254		
3	84.3901.050	21	81.4838.000		
4	86.3703.000	22	19.0031.204		
5	19.0031.330	23	19.0031.274		
6	85.1486.000	24	19.0031.100		
7	83.5769.000	25	86.3740.000		
8	85.1486.000	26	84.3843.060		
9	83.5768.000	27	11.0031.230		
10	19.0031.334	28	81.0625.000		
11	85.1486.000	29	11.0031.231		
12	83.5678.000	30	86.3981.000		
13	19.0031.250	31	82.6038.000		
14	19.0031.251	32	06.0031.247		
—	19.0031.252	33	6058.060.01.72(R)		
15	84.3901.050	—	6058.060.03.72 (C)		
16	84.3843.060	34	6058.060.02.73(R)		
17	81.4706.050	35	6058.060.03.73(C)		
18	19.0031.253	36	81.4767.000		

Gültigkeitsvermerk
Usage Code

(R) Rockinger
(C) Cramer

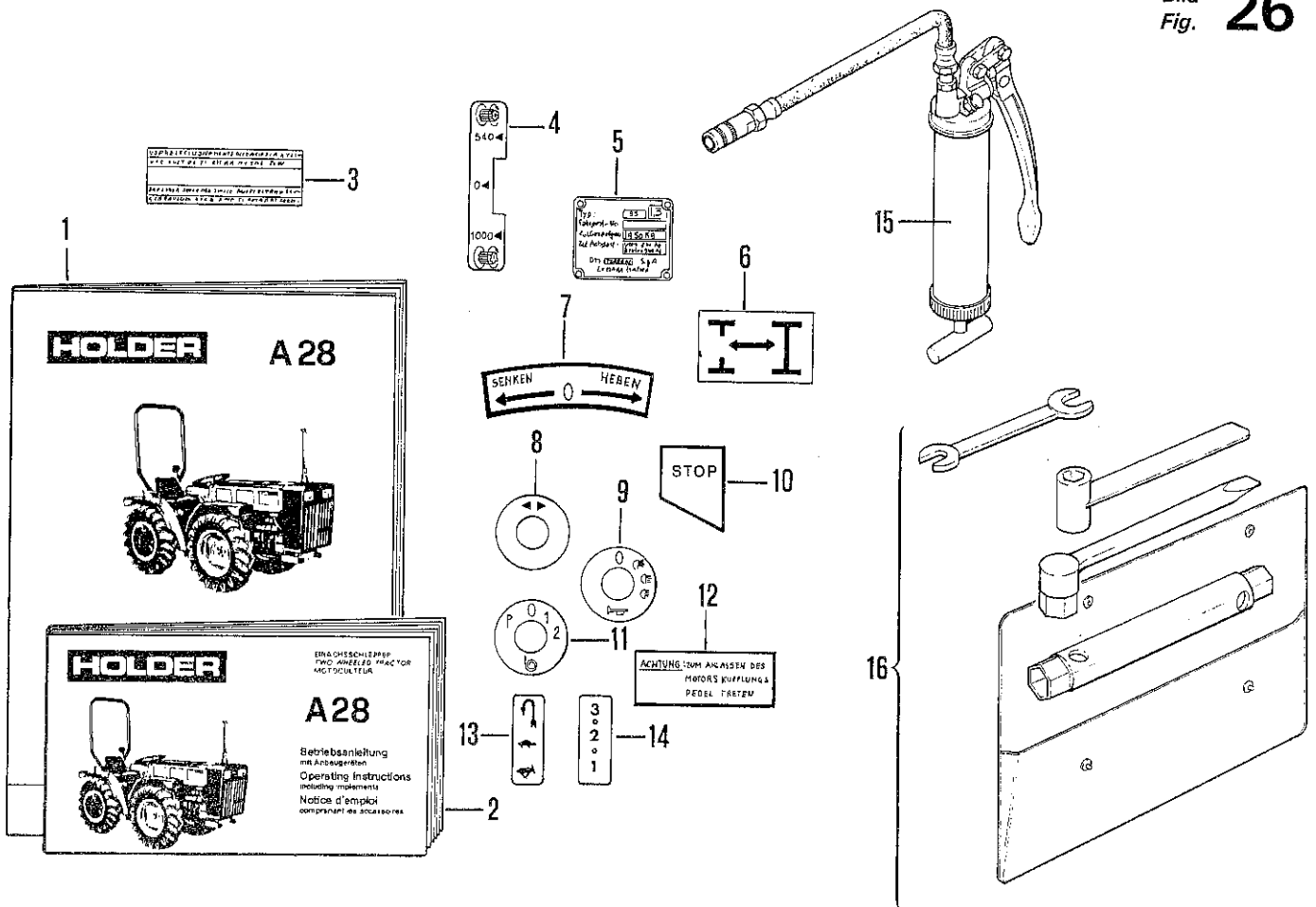

No. pezzo No. piece No. pièce No. Bild No. pieza	No. di ordinazione Part No. No. de commande Bestell. - Nr. No. de pedido	No. pezzo No. piece No. pièce No. Bild No. pieza	No. di ordinazione Part No. No. de commande Bestell. - Nr. No. de pedido	No. pezzo No. piece No. pièce No. Bild No. pieza	No. di ordinazione Part No. No. de commande Bestell. - Nr. No. de pedido
1	117.306				
2	117.199				
3	85.4067.010				
4	19.0033.984				
5	19.0033.979				
6	85.3811.000				
7	19.0033.980				
8	19.0033.266				
9	19.0033.264				
10	19.0033.982				
11	19.0033.265				
12	19.0033.981				
13	85.4064.010				
14	85.4063.010				
15	82.6761.000				
16	19.0065.010				

Gültigkeitsvermerk
Usage Code

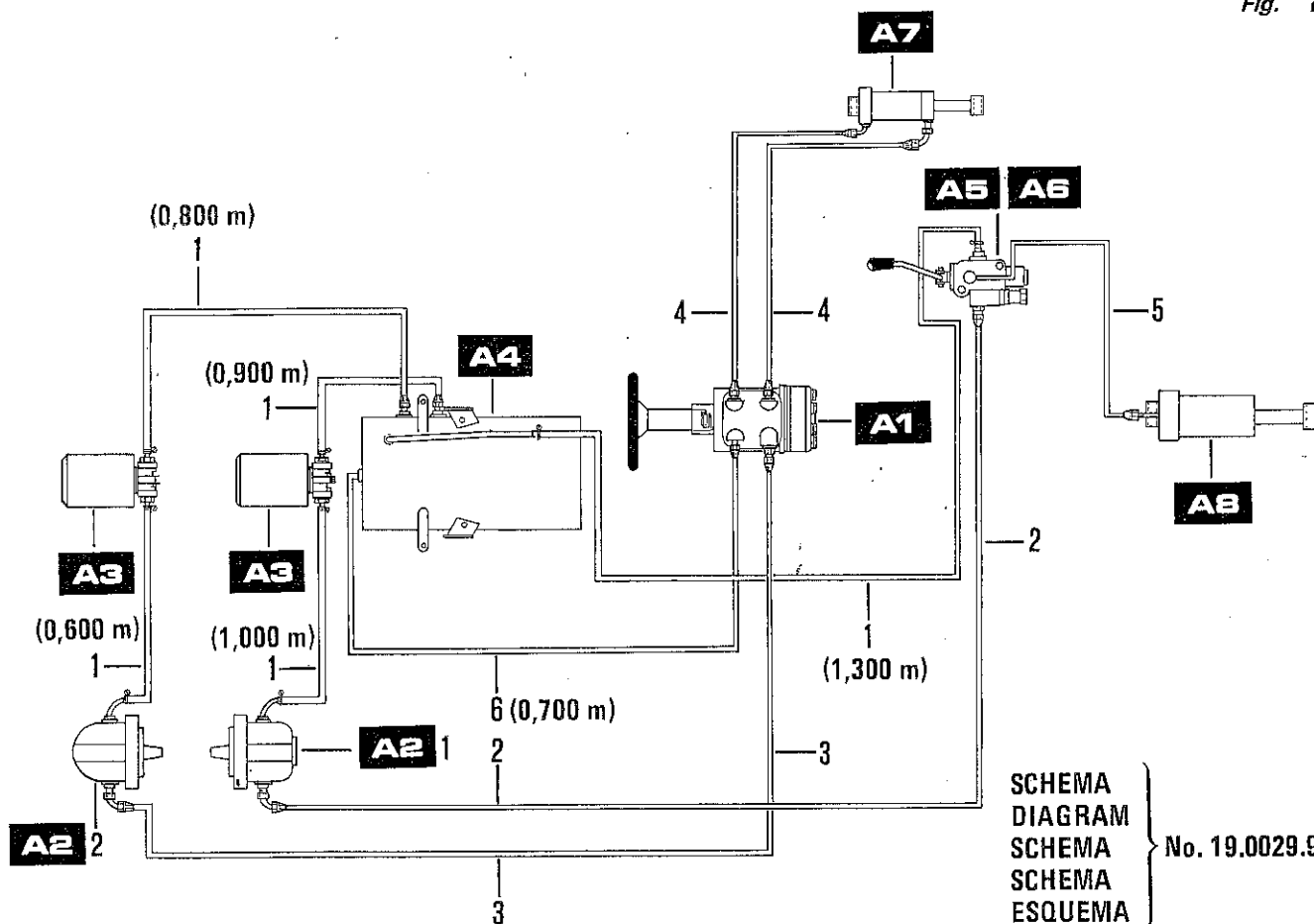

SCHEMA
DIAGRAM
SCHEMA
ESQUEMA } No. 19.0029.958

No. pezzo No. pièce No. Bild No. pieza	No. di ordinazione Part No. No. de commande Bestell. - Nr. No. de pedido	MICROFICHE	Tipo Type Typ Modelo	Costruttore Manufacturer Constructeur Konstrukteur Constructor	No. di ordinazione Part No. No. de commande Bestell. - Nr. No. de pedido	Motore Engine Moteur Motor Motor
1	25.6612.916	A2 1	AM-2/24S	HIDROIRMA	83.6565.000	914
2	19.0029.931	A2 2	AM-2/24D	HIDROIRMA	83.6509.000	914
3	19.0029.911					
4	11.0029.934					
5	19.0029.900	A5 A6	HD151-K1-E2 LO/4VM	HIDROIRMA	81.6653.000	
6	25.6614.916					
		A1	OSPC800N	DANFOSS	86.5472.000	

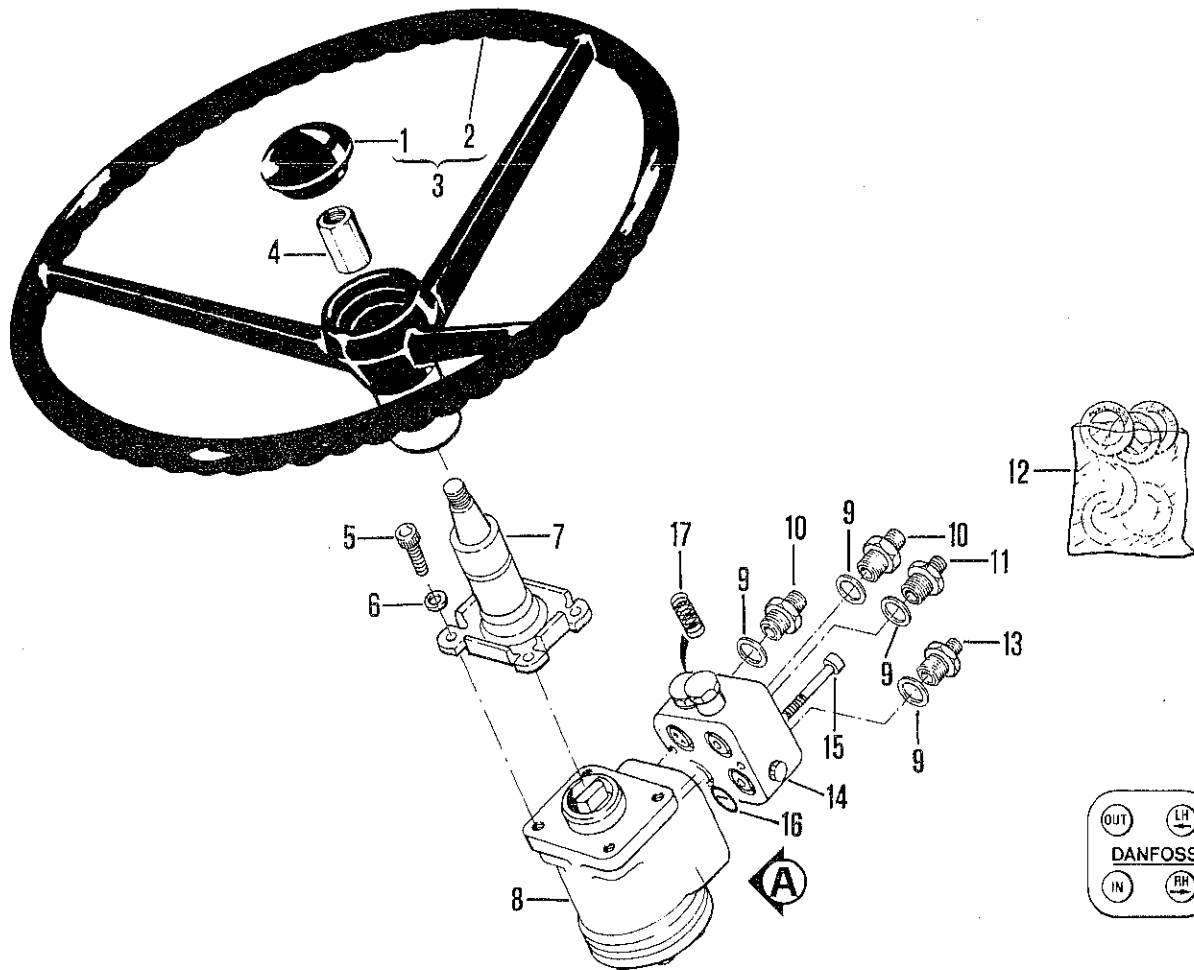

No. pezzo No. pièce No. pièce No. Bild No. pieza	No. di ordinazione Part No. No. de commande Bestell. - Nr. No. de pedido	No. pezzo No. pièce No. pièce No. Bild No. pieza	No. di ordinazione Part No. No. de commande Bestell. - Nr. No. de pedido	No. pezzo No. pièce No. pièce No. Bild No. pieza	No. di ordinazione Part No. No. de commande Bestell. - Nr. No. de pedido
1	86.5017.020				
2	86.5017.010				
3	86.5017.000				
4	19.0030.266				
5	86.3359.000				
6	84.3577.010				
7	84.5472.050				
8	86.5472.000				
9	82.4141.000				
10	83.5040.000				
11	83.5041.000				
12	19.0028.906				
13	83.5037.000				
14	86.5472.060				
15	86.3440.000				
16	80.3204.000				
17	82.5706.010				

A2 2

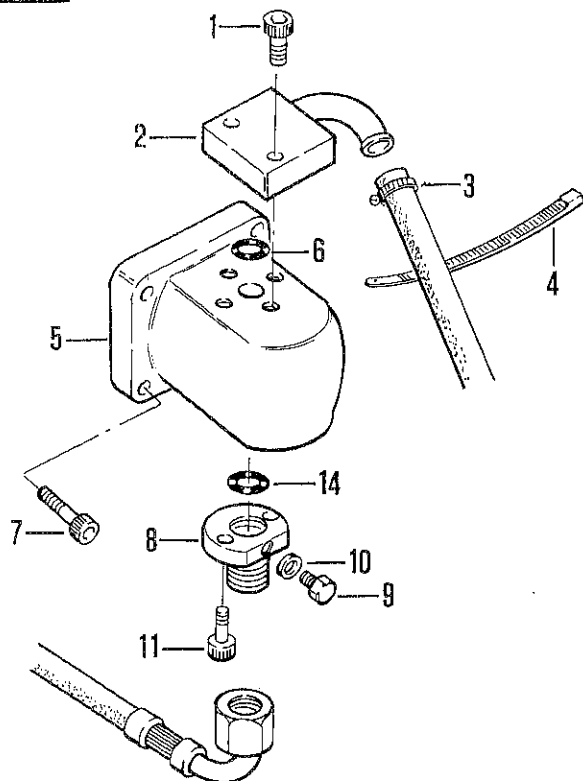

A2 1

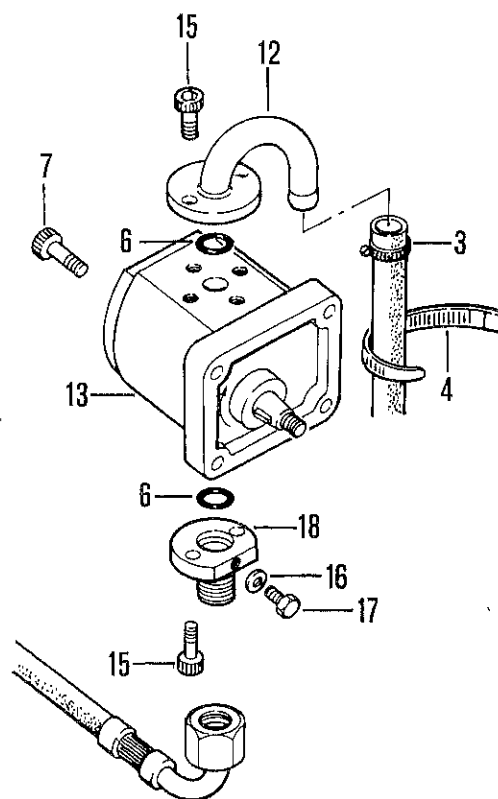

No. pezzo No. pièce No. pièce No. Bild No. pieza	No. di ordinazione Part No. No. de commande Bestell. - Nr. No. de pedido	No. pezzo No. pièce No. pièce No. Bild No. pieza	No. di ordinazione Part No. No. de commande Bestell. - Nr. No. de pedido	No. pezzo No. pièce No. pièce No. Bild No. pieza	No. di ordinazione Part No. No. de commande Bestell. - Nr. No. de pedido
1	86.2270.010				
2	19.0029.227				
3	81.7519.000				
4	01.0001.405				
5	83.6509.000				
6	80.3185.000				
7	86.2194.000				
8	82.5809.000				
9	86.2462.010				
10	82.4022.000				
11	86.2108.050				
12	19.0029.228				
13	83.6565.000				
14	80.3185.000				
15	86.2108.050				
16	82.4022.000				
17	86.2462.010				
18	82.5809.000				

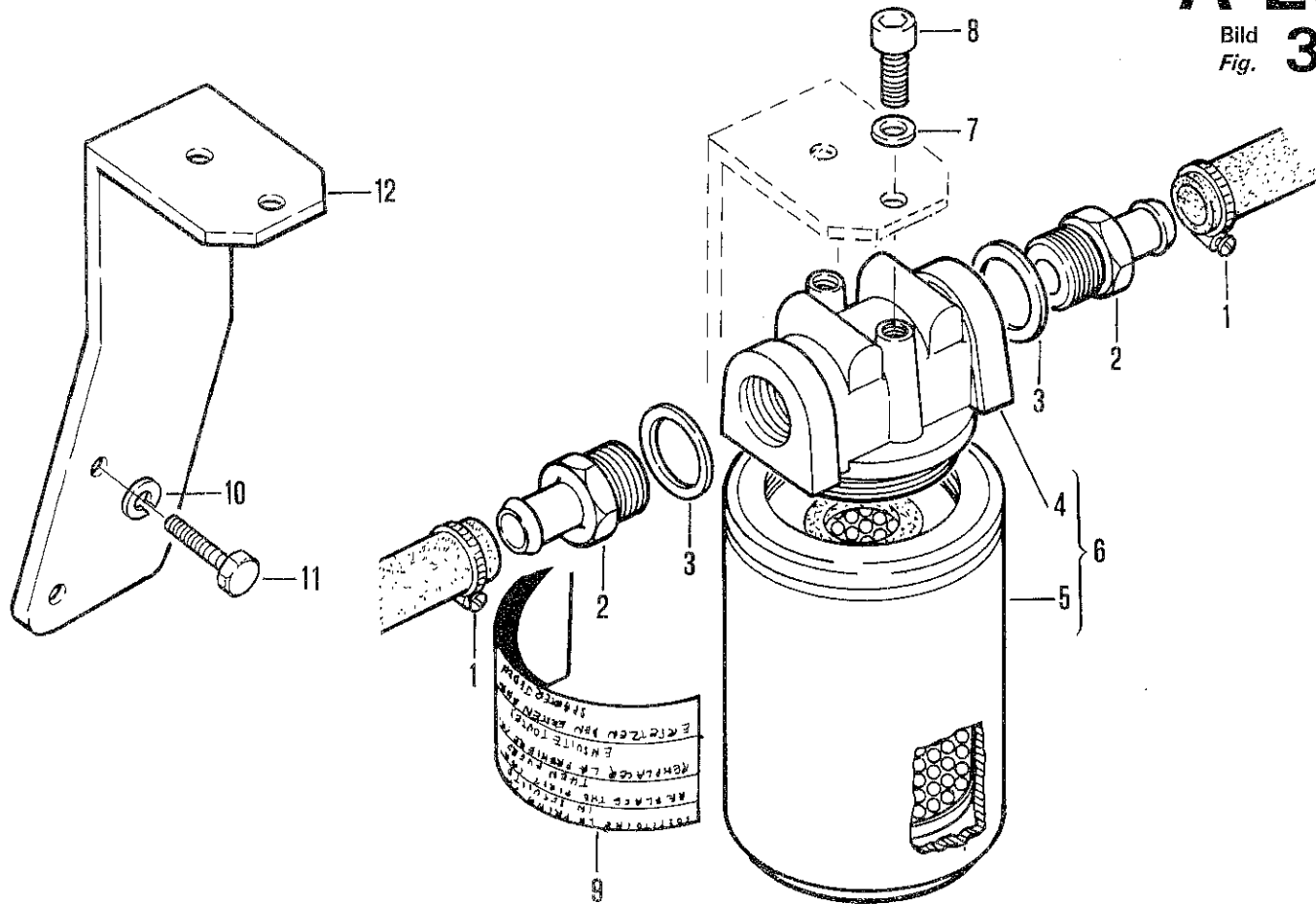

No. pezzo No. pièce No. Bild No. pieza	No. di ordinazione Part No. No. de commande Bestell. - Nr. No. de pedido	No. pezzo No. pièce No. Bild No. pieza	No. di ordinazione Part No. No. de commande Bestell. - Nr. No. de pedido	No. pezzo No. pièce No. Bild No. pieza	No. di ordinazione Part No. No. de commande Bestell. - Nr. No. de pedido
1	81.7519.000				
2	83.5060.030				
3	82.4185.000				
4	82.5718.010				
5	82.5718.020				
6	82.5718.000				
7	84.3643.060				
8	86.2555.000				
9	85.4067.050				
10	84.3755.000				
11	86.3254.000				
12	19.0033.879				

Gultigkeitsvermerk
Usage Code

A3

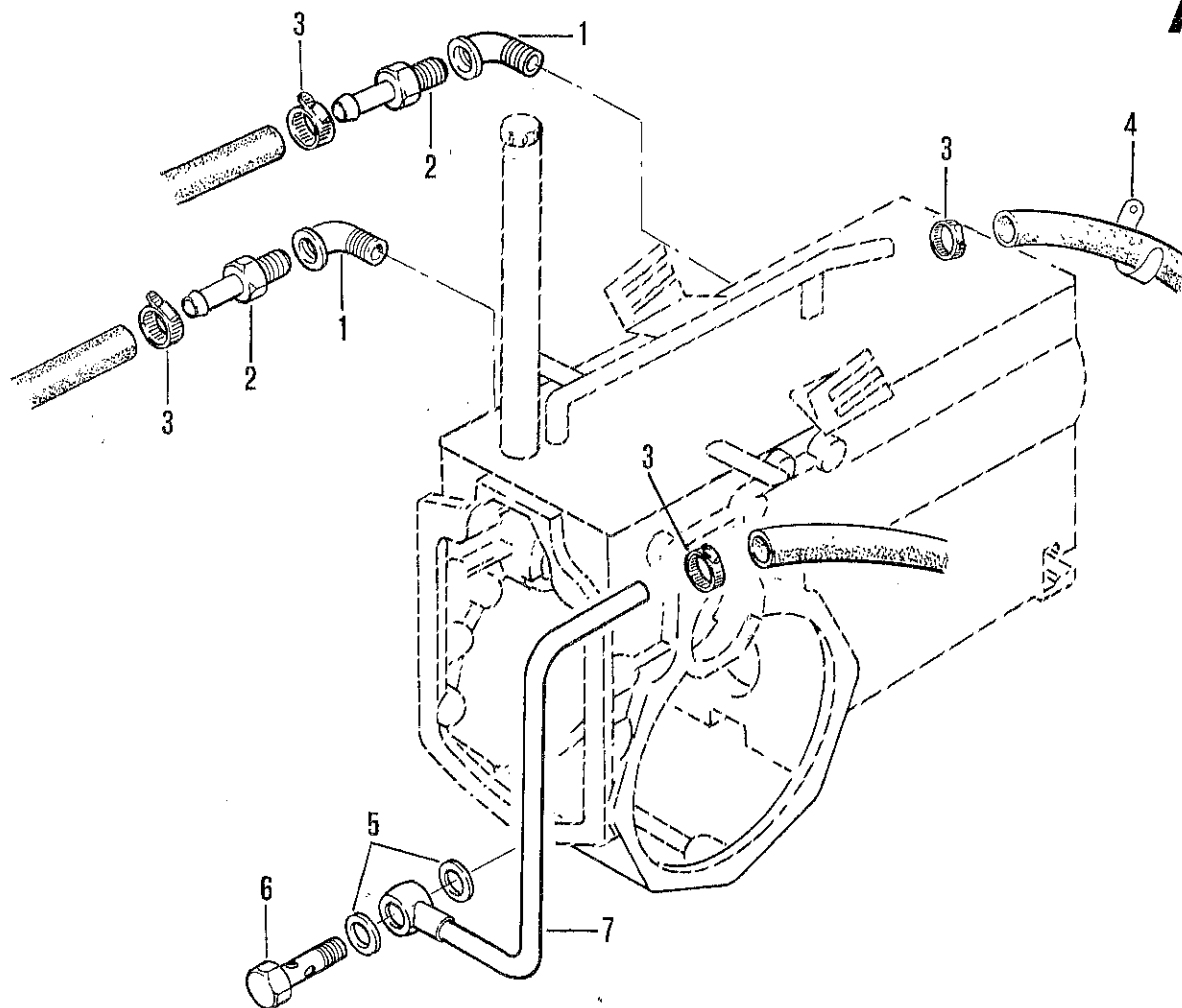

No. pezzo No. pièce No. pièce No. Bild No. pieza	No. di ordinazione Part No. No. de commande Bestell. - Nr. No. de pedido	No. pezzo No. pièce No. pièce No. Bild No. pieza	No. di ordinazione Part No. No. de commande Bestell. - Nr. No. de pedido	No. pezzo No. pièce No. pièce No. Bild No. pieza	No. di ordinazione Part No. No. de commande Bestell. - Nr. No. de pedido
1	84.0544.000				
2	83.5041.000				
3	81.7519.000				
4	01.0001.405				
5	82.4141.000				
6	84.3116.000				
7	19.0029.229				

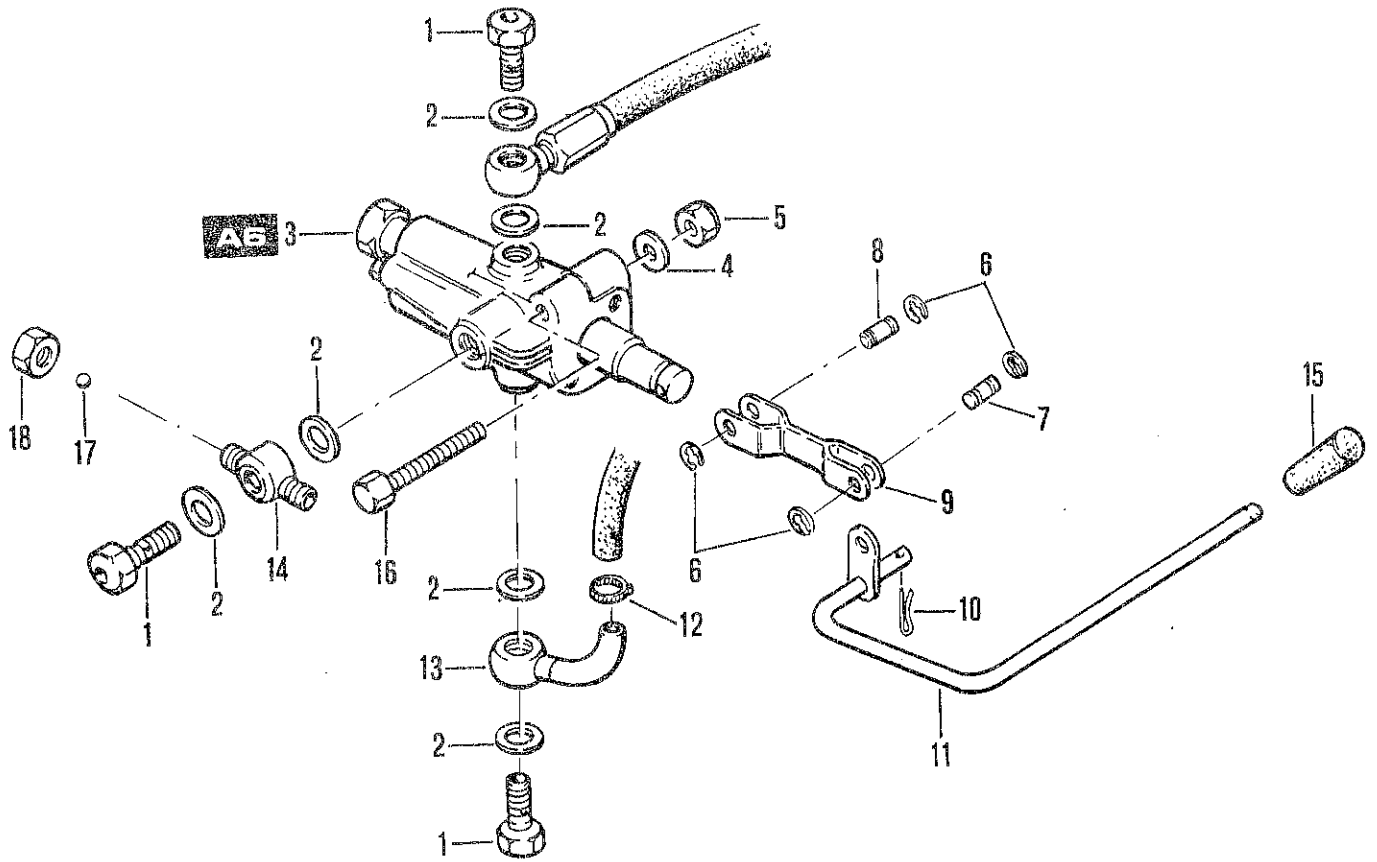

No. pezzo No. pièce No. pièce No. Bild No. pieza	No. di ordinazione Part No. No. de commande Bestell. - Nr. No. de pedido	No. pezzo No. pièce No. pièce No. Bild No. pieza	No. di ordinazione Part No. No. de commande Bestell. - Nr. No. de pedido	No. pezzo No. pièce No. pièce No. Bild No. pieza	No. di ordinazione Part No. No. de commande Bestell. - Nr. No. de pedido
1	84.3110.000				
2	82.4113.000				
3	81.6653.000				
4	84.3685.000				
5	81.4588.000				
6	80.1018.000				
7	19.0029.203				
8	83.5516.000				
9	19.0029.202				
10	81.0505.000				
11	19.0029.205				
12	81.7519.000				
13	84.2514.000				
14	84.2517.000				
15	83.7534.000				
16	86.2944.000				
17	84.7462.000				
18	81.4551.000				

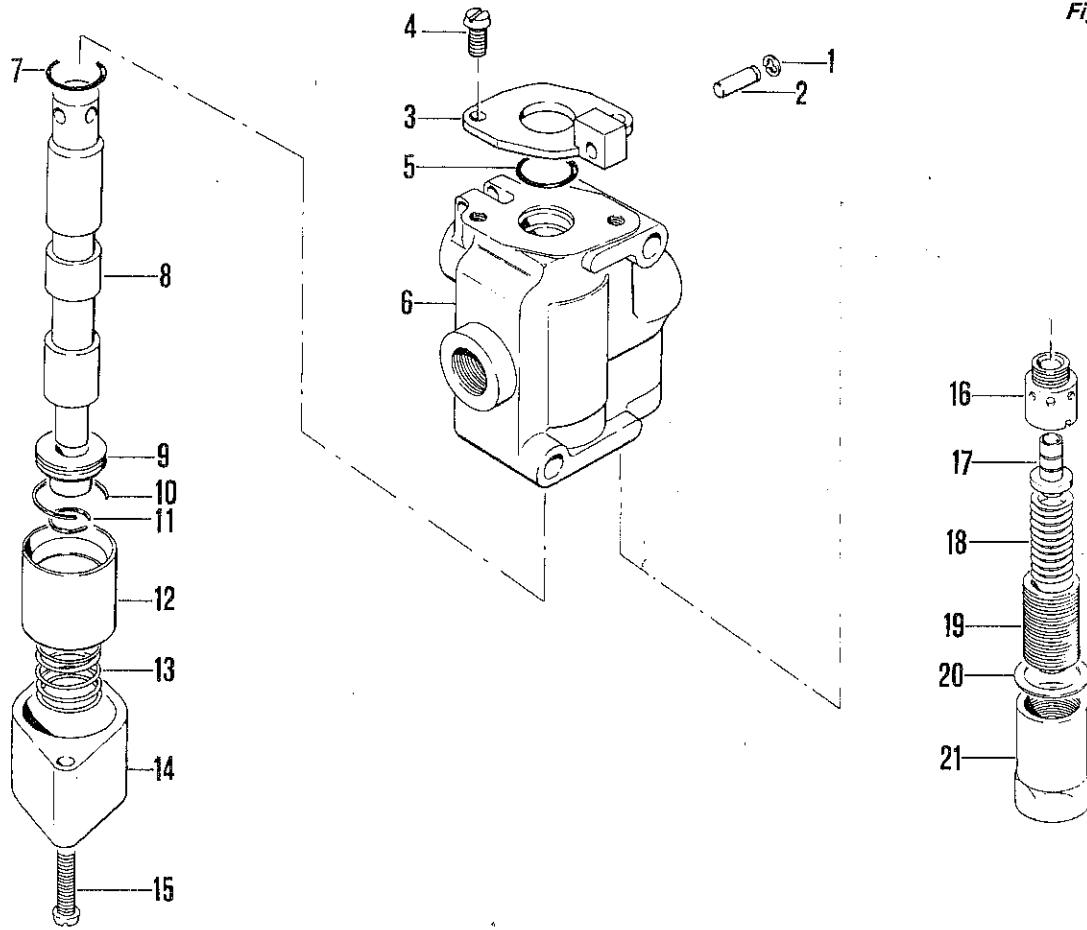

No. pezzo No. pièce No. Bild No. pieza	No. di ordinazione Part No. No. de commande Bestell. - Nr. No. de pedido	No. pezzo No. pièce No. Bild No. pieza	No. di ordinazione Part No. No. de commande Bestell. - Nr. No. de pedido	No. pezzo No. pièce No. Bild No. pieza	No. di ordinazione Part No. No. de commande Bestell. - Nr. No. de pedido
1	80.1018.000	19	81.6651.050		
2	83.5516.000	20	84.4206.000		
3	81.6650.080	21	81.6651.060		
4	86.1970.000				
5	80.3240.000				
6	81.6650.010				
7	80.3240.000				
8	81.6650.020				
9	81.6650.030				
10	81.6650.040				
11	80.1075.000				
12	81.6650.050				
13	81.6650.060				
14	81.6650.070				
15	86.2349.000				
16	81.6651.020				
17	81.6651.030				
18	81.6651.040				

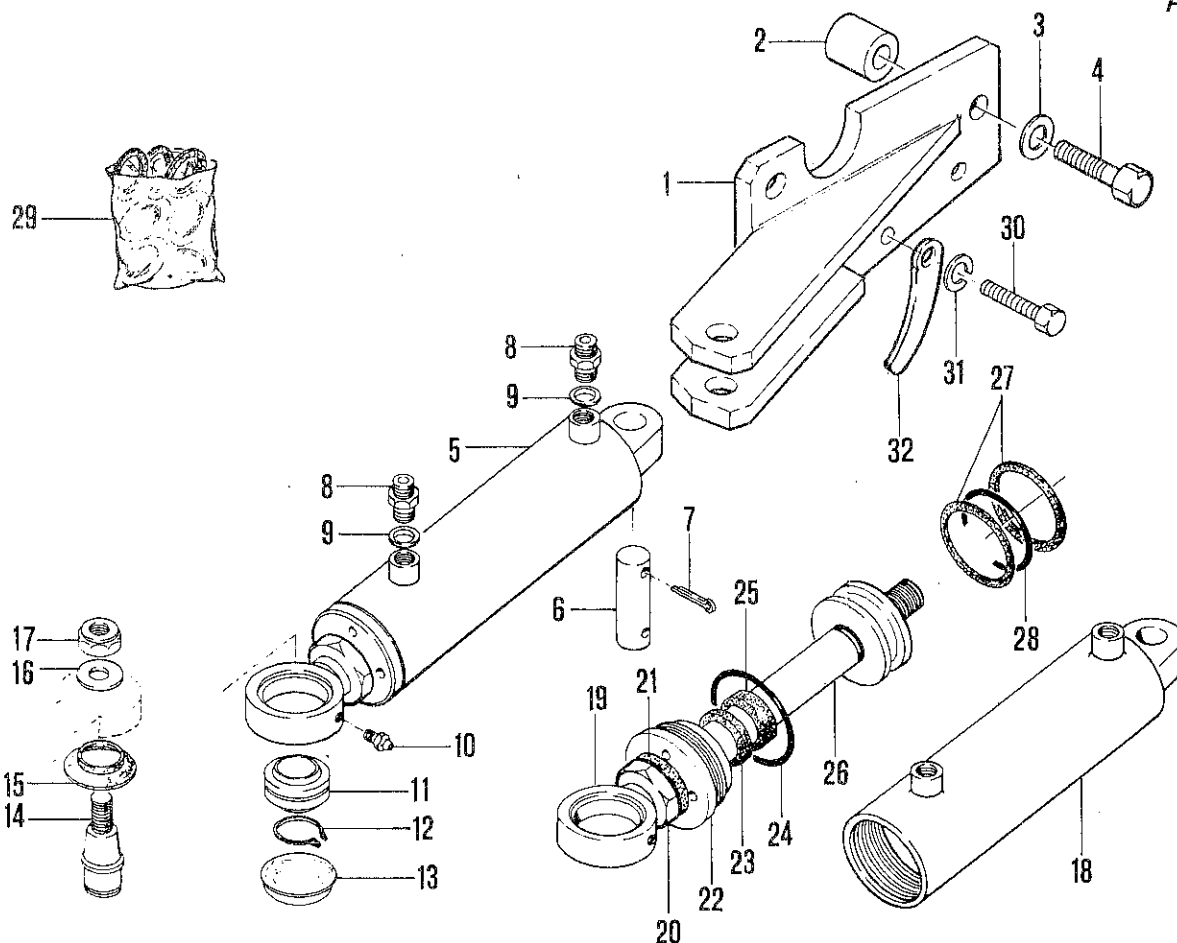

No. pezzo No. pièce No. pièce No. Bild No. pieza	No. di ordinazione Part No. No. de commande Bestell. - Nr. No. de pedido	No. pezzo No. pièce No. pièce No. Bild No. pieza	No. di ordinazione Part No. No. de commande Bestell. - Nr. No. de pedido	No. pezzo No. pièce No. pièce No. Bild No. pieza	No. di ordinazione Part No. No. de commande Bestell. - Nr. No. de pedido
1	19.0030.200	20	81.4809.010		
2	19.0030.201	21	80.9331.090		
3	84.3843.060	22	80.9329.010		
4	86.4007.050	23	80.9331.080		
5	80.9329.000	24	80.3277.000		
6	83.5775.050	25	80.9331.070		
7	81.0625.000	26	80.9320.020		
8	83.5006.000	27	80.9331.050		
9	84.3907.000	28	80.9331.040		
10	82.6016.000	29	16.0027.905		
11	81.1950.000	30	86.3429.000		
12	80.1160.000	31	84.3755.000		
13	85.2756.000	32	01.0001.405		
14	11.0030.226				
15	81.1955.000				
16	84.3927.050				
17	81.4765.000				
18	80.9320.010				
19	80.9320.050				

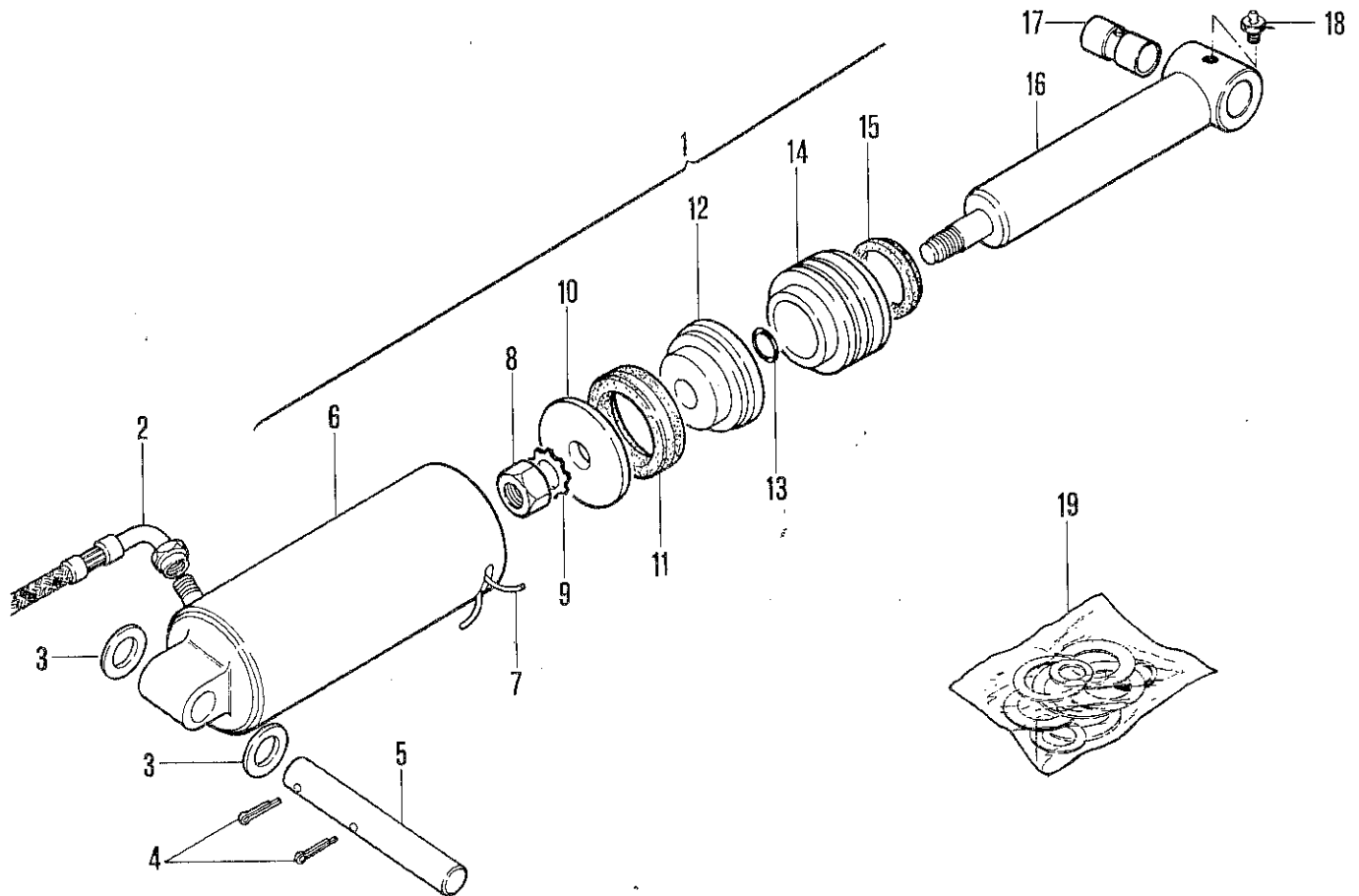

No. pezzo No. pièce No. pièce No. Bild No. pieza	No. di ordinazione Part No. No. de commande Bestell. - Nr. No. de pedido	No. pezzo No. pièce No. pièce No. Bild No. pieza	No. di ordinazione Part No. No. de commande Bestell. - Nr. No. de pedido	No. pezzo No. pièce No. pièce No. Bild No. pieza	No. di ordinazione Part No. No. de commande Bestell. - Nr. No. de pedido
1	80.9319.000				
2	19.0029.900				
3	84.4230.000				
4	81.0561.000				
5	83.5808.000				
6	80.9319.010				
7	80.9325.000				
8	81.4793.000				
9	84.4040.000				
10	80.9326.000				
11	80.2239.040				
12	80.9303.000				
13	80.3186.000				
14	80.9324.000				
15	80.2176.000				
16	80.9323.000				
17	80.4250.000				
18	82.6038.000				
19	11.0029.806				

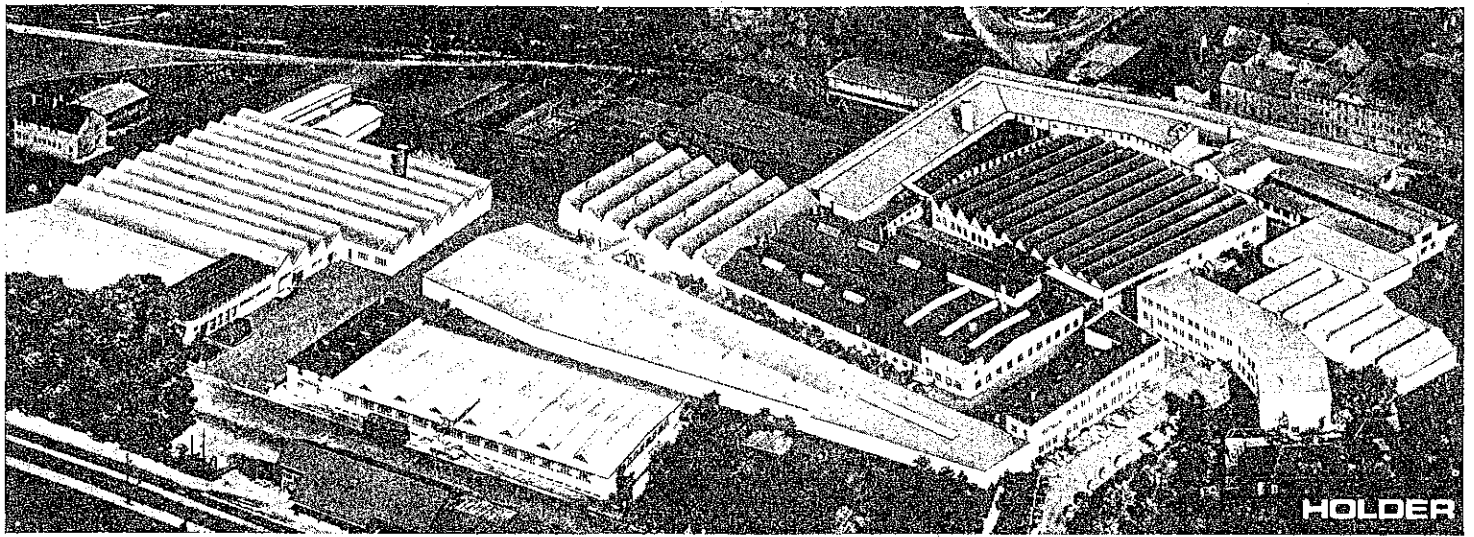

HOLDER- Lieferprogramm	HOLDER- Production Program	Programme de Fabrication HOLDER	Programa de construcción HOLDER
Motorhacken	Motor-Cultivators	Motobineuses	Motoazadas-Motocultivadores
Einachsschlepper	Two-wheel Tractors	Motoculteurs Universels	Tractores de 4 ruedas
Vierradschlepper	Four-wheel Tractors	Tracteurs	Tractores con tracción a las
4-Rad-Antrieb-Schlepper	4-Wheel Drive Tractors	Tracteurs 4 roues motrices	4 ruedas
Hand-Rücken-Karren- Spritzen	Hand-Knapsack-Wheel- Barrow Sprayers	Pulvérisateurs à main — à dos — sur brouette	Pulverizadores de mano — de mochila — en carreta
Motor-Spritzen	Motor Sprayers	Pulvérisateurs à moteur	Pulverizadores de motor
Motorsprühgeräte	Motorized Mist Blowers	Atomiseurs — Poudreuses	Aparatos atomizadores motrices
Motorstäubegeräte	Motorized Dusters	Pompes à prise de force	Aparatos espolvoreadores
Zapfwellenpumpen	Power take-off Pumps	Pulvérisateurs portés sur tracteurs	Bombas de tdf
Schlepperanbauspritzen	Tractor-mounted Sprayers	Atomiseurs portés	Pulverizadores para montar en tractores - Nebulizadores
Anbausprühgeräte	Spraying attachment		
Fordern Sie Prospekte an	Please ask for leaflets	Veillez demander des prospectus	Pidanos Vd. Prospectos