

## Operating Instructions

### C-Trac

C 9700

C 9700 H

C 9800 H

C 9.72

C 9.72 H

C 9.83 H

C 9.78 H

C 9.88 H





## Foreword

We congratulate you for having chosen a product from HOLDER. We would like you to be able to work safely with your tractor and without malfunctions, and therefore we recommend you follow the instructions in this operating manual. You also ensure getting full value from your tractor, save yourself trouble and maintain your warranty. The operating manual provides you with the required information.

### Development

Due to the continuous improvements made in the design and equipment of our tractors, deviations between this operating manual and your tractor may be possible.

Despite taking all care possible in the creation of this manual, we cannot fully exclude mistakes. Please note that the technical data, illustrations and descriptions contained in this manual are not binding and no legal claims can be made on the basis hereof.

This operating and maintenance manual is supplied with each tractor. Keep this in a safe place where it is available for the driver and owner at any time. If they should get lost, the owner must get a replacement from the manufacturer.

The personnel concerned with the operation and maintenance of the tractors must be made acquainted with the operating

and maintenance manual. The owner must ensure that every operator has received, read and understood this manual. We thank you for reading and observing this manual. In case you still have any questions, suggestions for improvements or discovered mistakes, please contact our customer service.

### General Notes on Service

Detach the warranty card, have it filled in by your dealer and send the signed card to us.

Have the scheduled services carried out at the proper intervals and have it confirmed with the dealer's stamp and signature in this manual. Please note that warranty can only be claimed if the regular services have been carried out as scheduled.

Descriptions and illustrations can be related to special equipment not installed in your tractor.

## Foreword

In case of questions regarding your tractor, please state the following data:

Tractor Model ..... eg C 9800 H  
Engine Serial Number ..... eg 00542087  
Chassis Serial Number ..... eg 52410101  
Date of Sale, or Date of Complaint ..... eg 02.01.2003  
Operating Hours ..... eg 2860 service hours

## Date of Issue and Manual Version

**November 2002**

We wish you safe driving and troublefree working with your HOLDER C-Trac.

Gebrüder Holder GmbH  
Max-Holder-Straße 1  
72555 Metzingen

Phone (Germany) 07123 966 - 0  
Fax 07123 966 - 228  
E-mail: info@holder-gmbh.com  
www.holder-gmbh.com

## Explanations of Terminology:



### **DANGER**

*Indicates procedures which must be observed exactly to prevent danger to the life and limbs of persons.*



### **CAUTION**

*Indicates procedures which must be observed exactly to prevent personal injuries.*



### **ATTENTION**

*Indicates procedures which must be observed exactly to prevent damage to and/or destruction of objects and equipment.*



### **NOTE**

*Indicates technical requirements requiring special attention.*

**Table of Contents**

<b>Chapter</b>	<b>Page</b>	<b>Chapter</b>	<b>Page</b>
Foreword .....	1	Maintenance Schedule .....	157
Instructions for the Tractor .....	5	Maintenance during the First Period of Operation .....	161
Instructions for Operation .....	7	Maintenance as Required .....	163
Technical Data .....	15	Maintenance According to Intervals .....	169
Description .....	28	Maintenance Every 125 Service Hours .....	169
Taking into Service .....	49	Maintenance Every 500 Service Hours .....	177
Operation .....	63	Maintenance Every 1000 Service Hours .....	183
Operating Implements .....	85	Maintenance Every 1500 Service Hours .....	187
Other Activities .....	119	Maintenance Every 3000 Service Hours .....	197
Taking out of Operation .....	133	Maintenance Annually .....	199
Trailers, Towing .....	135	Maintenance Every 2 Years .....	199
Transport, Loading, Towing .....	139	Laying Up .....	201
Indicators, Adjustments .....	141	Recommended Oils and Fuels .....	203
Problems, Causes, Remedy .....	143	Alphabetical Index .....	213
General Notes on Maintenance .....	149		



## Instructions for the Tractor

After the safety test, this tractor has received the operating permit acc. to 74/150/EEC. The tractor conforms to the EMC (Electromagnetic Compatibility) requirements of directive 89/336/EEC. The regulations for exhaust gas identification and the noise emissions are observed. The tractor must be registered and the license plate must be attached at the front and/or rear if applicable.

### Approved Applications

The tractor can be used for towing trailers and for mounting various attachments. The maximum trailer load, which must not be exceeded, is stated on the identification plate. The transport of persons is only allowed on the passenger seat. The tractor is designed solely for the customary type of operation in farming and forestry, the upkeep of municipal facilities, including operation in winter. The tractor may only be used as intended and described in this operating manual. The intended use also includes the use following the specified maintenance and repair recommendations. The tractor, together with its attachments, may only be used, serviced and repaired by persons familiar with this equipment and have been warned of possible risks. The applicable safety regulations must be strictly observed, along with all other

recognized rules regarding industrial health, safety at work and the highway traffic code.

### Site of Operation

The tractor must be used in the open. Its operation on public roads is allowed. When using the public highway, respect the high way code in your country.

### Unintended Applications

Any use not intended as described as above is not authorized. The Supplier HOLDER will not be responsible for any hazard resulting from unintended applications. The Supplier will also not be responsible for any resulting damages, they shall be solely borne by the user. The tractor may not be used for any other purposes than those described in this manual. Do not carry persons on the loading area or on attachments.

## Instructions for the Tractor

### Residual Hazards and Risks

Despite all care being taken and in conformance with standards and regulations, it is not possible to exclude all risks in the handling of the tractor.

The tractor and all other system components conform to currently applicable safety regulations. Nevertheless, a residual risk cannot be excluded even by authorized use of the tractor and observation of all the safety notices given.

For this reason, persons standing in the area of the tractor and attachments must exercise particular caution in order to be able to react directly in case of a malfunction, an incident, a failure, etc.



#### **CAUTION**

*All persons standing in the area of the tractor and implements must be advised of the risks which can result from their operation. Furthermore, read and observe the other safety rules and regulations contained in this operating manual.*

The risks can include:

- Unexpected movements of the implements and tractor.
- Escape of fuel and lubricants due to leaks, broken lines and reservoirs, etc.
- Risk of accidents when driving, steering and braking due to unfavourable ground conditions such as slopes, icy roads, unevenness or poor visibility, etc.
- Falling, stumbling, etc. when moving on the tractor, particularly when it is wet.
- Fire and explosion hazards due to the battery and electric currents.
- Danger of poisoning through Diesel exhaust gases
- Danger of fire through Diesel fuel and oils
- Human errors due to non-observance of the safety rules.

#### **Note on Disposal of Tractor**

Your tractor is made of different materials. Each material should be disposed of/treated/recycled according to different regional/national regulations. We recommend contacting a salvage company.



## Instructions for Operation

### Driver's license

For the operation of this vehicle you need a **driver's license** dependent of the maximum speed and the permissible total weight of the vehicle or the combination. See the tables below. Please observe your national laws.

### Driver's license classes (Germany only)

Tractors for farming and forestry (also with implements)

Maximum Speed (dependent on type)	Maximum Total Weight	Driver's License Class (Minimum Requirements)	Former Driver's License Class
up to 32 km/h	no limitation	B, L, T	1, 1a, 1b, 2, 3, 4, 5
over 32 km/h	up to 3.5 tons	B T: 60 km/h, under 18 years only 40 km/h	2, 3
	over 3.5 tons to 7.5 tons	C1 T: 60 km/h, under 18 years only 40 km/h	2, 3

## Instructions for Operation

Single-axle Trailers or Two-axle Trailers with an Axle Base of up to max. 1 m

Maximum Total Weight	Driver's License Class (Minimum Requirements)	Former Driver's License Class
up to 750 kg trailer weight	B, C1, C, T  L: (25) only with additional sign and maximum tractor speed of 25 km/h (depending on type)	1, 1a, 1b, 2, 3, 4, 5
over 750 kg trailer weight	BE, C1E, CE, T  B, C1, C: only up to 3.5 tons adm. total weight of the combination and adm. total weight of trailers $\leq$ dead weight of tractor; otherwise: (25)  C1E: only up to 12 tons adm. total weight of combination and adm. total weight of trailer $\leq$ dead weight of tractor; otherwise: (25)  L: (25)	1, 1a, 1b, 2, 3, 4, 5

### Multiple-axle Trailers and Two-axle Trailers with an Axle Base over 1 m

Maximum Total Weight	Driver's License Class (Minimum Requirements)	Former Driver's License Class
up to 750 kg trailer weight	B, C1, C, T  L: (25) only with additional sign and maximum tractor speed of 25 km/h (depending on type)	2, 3
over 750 kg trailer weight	BE, C1E, CE, T	2, 3
up to 3.5 tons Maximum Total Weight	B, C1, C: only up to 3.5 tons adm. total weight of the combination and adm. total weight of trailers ≤ dead weight of tractor; otherwise: (25)	1, 1a, 1b, 4, 5: in each case (25)
up to 12 tons Maximum Total Weight	C1E: only up to 12 tons adm. total weight of combination and adm. total weight of trailer ≤ dead weight of tractor; otherwise: (25)  L: (25)	

## Instructions for Operation

Two Trailers behind Tractors for Farming and Forestry

Maximum Total Weight	Driver's License Class (Minimum Requirements)	Former Driver's License Class
up to 3.5 Maximum Total Weight	BE, C1E, CE, T  B, C1, C in each case only up to 3.5 tons adm. total weight of the combination and adm. total weight of trailers ≤ dead weight of tractor; otherwise: (25)	2, 3  1, 1a, 1b, 4, 5, (25)
up to 12 Maximum Total Weight	C1E: only up to 12 tons adm. total weight of combination and adm. total weight of trailer ≤ dead weight of tractor; otherwise: (25)  L: (25)	

**Instructions for Operation****Safety****General Notes on Safety**

- Observe the VSG 3.1 (German regulations for safety and health protection).
- Do not allow children under 16 to use the tractor.
- When using the public highway, respect the highway code.
- Do not allow anyone to stand around where they might get hurt.
- Do not run the engine in enclosed spaces.
- Exercise extreme caution when handling fuels - there is a high risk of fire.
- Exercise extreme caution when handling fuels and oils; these can be poisonous and caustic.
- To prevent the danger of fire, keep the tractor and implements clean.
- Observe the warning notices and symbols on your tractor.

**Working Clothes**

- Only wear snugly fitting clothing when working with the tractor.
- If necessary, wear suitable headwear to keep loose hairs and pigtales from being caught in rotating parts.
- Do not wear any jewellery and similar objects, eg rings, when working with the tractor.

**Safety Notes for Later Installations**

The tractor has electronic components whose proper functioning can be influenced by the electromagnetic emissions of other equipment. These influences can endanger persons if the following notes on safety are not observed.

- Have your equipment installed only by an authorized workshop.
- Before the installation of electric or electronic equipment connected to the tractor's electrical system, check if these installations can interfere with the tractor's electronic system or other system components.

## Instructions for Operation

- The installed equipment must conform to the applicable EMC directive 89/336/EU and carry the CE symbol.
- If you must install a mobile communications system (or have it installed) (eg radio, mobile telephone), the following requirements must be met:
  - Only approved equipment (eg BTZ approval in Germany) may be installed.
  - The equipment must be installed permanently.
  - The operation of portable or mobile equipment inside the vehicle is only allowed if connected to a permanently installed external antenna.
  - The transmitting section must be installed away from the tractor's electronic system.
  - When installing the antenna, install it properly and with a good connection vehicle ground.
  - Do not exceed the maximum permissible current rating of the wiring according to the installation instructions of the equipment manufacturer.

## Safety Instructions for Handling Fuels and Oils

### Gear Oil, Engine Oil, Diesel Fuel



Do not eat, drink or smoke when working with the product. Prolonged intensive contact may cause degreasing and irritation of the skin. Wash skin with soap and water, use skin care products. If required, wear protective gear. Change soaked clothes and shoes immediately. If vapour or mist was inhaled, breathe fresh air. Consult a doctor if the complaint persists. After contact with the eyes, rinse the eyes thoroughly with water (at least 10 minutes), then consult an eye doctor. If swallowed, do not force to vomit, but consult a doctor. Danger of slipping on the spilled product, especially in connection with water. Oils can contaminate water. Always keep them in approved containers. Avoid spilling oils. Remove spilled fluids at once with an oil binding agent and dispose of in accordance with laws and regulations. Discard drained fluids as specified. Observe all applicable laws and regulations. Oils are inflammable. Do not

**Instructions for Operation**

let them come in contact with hot engine parts as fire can result.

**Hydraulic Oil, Brake Fluid**

During tractor operation, these fluids are under pressure and a health hazard. Do not spill these fluids! Remove any spilled fluid at once with an oil binding agent and discard as specified. Dispose of old fluids as specified and follow the applicable laws and regulations. Do not allow them to come in contact with hot engine parts as fire can result. Danger of fire!

Avoid contact with the skin. Avoid the inhalation of spray fog. The penetration of the fluids into the skin is especially dangerous if the fluids are under high pressure and escape from the hydraulic system through leaks. Seek medical aid at once in case of such injuries.

If injuries cannot be excluded, use suitable protectors (for example, protective gloves, glasses and skin protection and care creams).

**Battery Acid**

Battery acid contains dissolved sulphuric acid. This acid is poisonous and caustic. When working with battery acid, always wear protective clothing and eye protectors. Do not allow acid to contact clothing, skin or eyes. In case of contact, wash directly with ample clean water. If personal injuries exist, seek medical aid at once. Neutralize spilled battery acid immediately.

Discard the old battery fluid as specified. Observe laws and regulations.

**Emissions****Exhaust Gases**

During operation, the engine emits exhaust gases into the environment. The exhaust gas mainly consists of water vapour, carbon dioxide (CO<sub>2</sub>), carbon monoxide (CO), hydrocarbon (CH), nitrogen oxide (NOX) and soot. The components CO, CH and NOX are poisonous or hazardous to health and should not be inhaled in high concentrations. Soot is a carcinogenic material; particularly the

## Instructions for Operation

particles in the exhaust gases can cause cancer. For this reason the engine may not be operated in enclosed spaces.

### Heat



The exhaust gases are very hot and can ignite inflammable material. The exhaust gas pipe should therefore be kept away from ignitable material.

### Battery



During charging, the battery produces a mixture of oxygen and hydrocarbon (detonating gas). This mixture of gases is explosive and may not be ignited. The risk of explosion can be avoided with proper ventilation and keeping naked flames away. Observe the safety rules when handling the battery.



## Technical Data

### Model Variants

Model	Transmission	Type of Drive	Type of Engine	Engine Performance
C 9700	Mechanical Reversing Gearbox	Mechanical	BF4M1011	53.5 kW $\triangleq$ 72 HP (DIN)
C 9700 H	Hydrostatic transmission	Hydrostatic	BF4M1011	53.5 kW $\triangleq$ 72 HP (DIN)
C 9800 H	Hydrostatic transmission	DUAL DRIVE*	BF4M1011F	61 kW $\triangleq$ 83 HP (DIN)
C 9.72	Mechanical Reversing Gearbox	Mechanical	BF4M1011	53.5 kW $\triangleq$ 72 HP (DIN)
C 9.72 H	Hydrostatic transmission	Hydrostatic	BF4M1011	53.5 kW $\triangleq$ 72 HP (DIN)
C 9.83 H	Hydrostatic transmission	DUAL DRIVE*	BF4M1011F	61 kW $\triangleq$ 83 HP (DIN)
C 9.78 H	Hydrostatic transmission	Hydrostatic	BF4M2011	57 kW $\triangleq$ 78 HP (DIN)
C 9.88 H	Hydrostatic transmission	DUAL DRIVE*	BF4M2011F	65 kW $\triangleq$ 88 HP (DIN)

\* mechanical + hydrostatic

## Technical data

### Tractor Dimensions

### Sketch

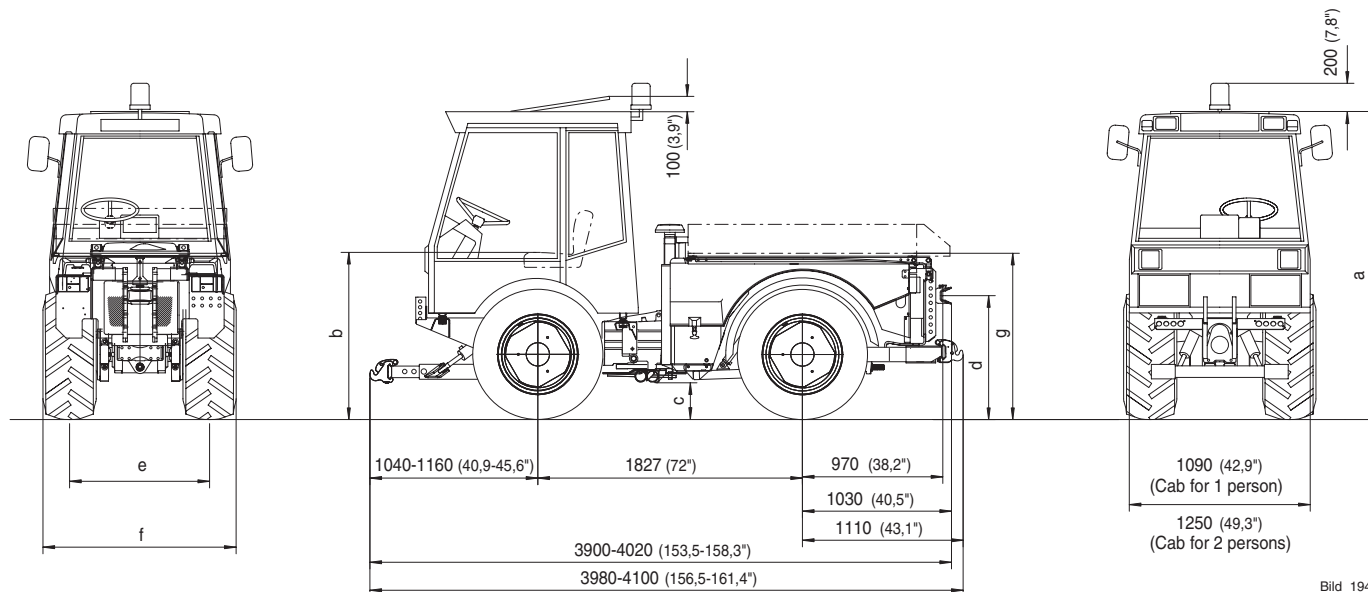

Data in brackets are American dimensions

Table of Dimensions

Tires	Type	Overall Height	Avg. Height of Seat	Ground Clearance	Trailer Coupling		Height of Body
					Lowest Position	Highest Position	
					d mm (Inches)	d mm (Inches)	
		a mm (Inches)	b mm (Inches)	c mm (Inches)			g mm (Inches)
10.5-18 MPT S	524-31-6	2130 (83.8)	1050 (41.3)	230 (9)	575 (22.4)	975 (38.2)	1130 (44.5)
10.5-18 MPT	524-31-1	2130 (83.8)	1050 (41.3)	230 (9)	575 (22.4)	975 (38.2)	1130 (44.5)
36x13.50-15	524-31-8	2100 (82.5)	1020 (40.1)	200 (7.9)	545 (21.3)	945 (37.1)	1095 (43.1)
400/60-15.5	524-31-5	2095 (82.3)	1030 (40.5)	195 (7.5)	540 (21.2)	940 (37)	1095 (43.1)
33x12,50-R15	524-31-7	2090 (82.2)	1020 (40.1)	190 (7.3)	535 (21.0)	935 (36.6)	1090 (42.9)
33/18LL-16.1	524-31-9	2090 (82.2)	1020 (40.1)	190 (7.3)	535 (21.0)	935 (36.6)	1090 (42.9)
33x12.50-15	524-31-4	2075 (81.4)	1010 (39.7)	180 (7)	525 (20.6)	925 (36.3)	1075 (42.3)
33x15.50-15	524-31-3	2075 (81.4)	1010 (39.7)	180 (7)	525 (20.6)	925 (36.3)	1075 (42.3)
31x15.50-15	524-31-2	2065 (81.1)	980 (38.6)	165 (6.4)	510 (20)	910 (35.8)	1060 (41.7)

## Technical data

### Track Widths

Tires	Min. Turning Radius to DIN 7020 (measured at outermost point of vehicle)  m	Normal Track Width (Flange size 1034)				With Hub Spacers							
		Track Width e		Overall Width f		Type 5234-80= 45 mm				Type 526-34-70= 80 mm			
		min.-mm	max.-mm	min.-mm	max.-mm	min.-mm	max.-mm	min.-mm	max.-mm	min.-mm	max.-mm	min.-mm	max.-mm
		36x13.50-15	7.28 m f. track w. 1084	-	1084	-	1439	1090	1174	1445	1529	1160	1244
10.5-18 MPT S	7.10 m f. track w. 960	960	1124	1230	1394	1124	1140	1320	1484	1120	1284	1390	1554
10.5-18 MPT	7.14 m f. track w. 1034	1034	1050	1304	1320	1050	1214	1394	1410	1194	1210	1464	1480
400/60-15.5	7.30 m f. track w. 1070	-	1070	-	1470	1106	1160	1506	1560	1176	1230	1576	1630
33x12.50 R15	7.15 m f. track w. 1000	1000	1084	1320	1404	1090	1174	1410	1494	1160	1244	1480	1564
33x12.50-15	7.15 m f. track w. 1000	1000	1084	1320	1404	1090	1174	1410	1494	1160	1244	1480	1564
33x15.50-15	7.24 m f. track w. 1124	*• 992	1124	* 1382	1514	1052	1214	1442	1604	1122	1284	1512	1674
33/18LL-16.1	7.45 m f. track w. 1164	-	1164	-	1636	-	1254	-	1726	-	-	-	-
31x15.50-15	7.30 m f. track w. 1124	*• 962	1124	* 1332	1494	1052	1214	1422	1584	1122	1284	1492	1654

\*Snow chains not possible

\* With track spacer type 526-34-75 (15 mm per wheel)

### Weights

All Tractors	Weight in kg
Permissible total weight	4500 kg (9920.6 LBS)
Permissible load on front axle	*2660 kg - 2700 kg (5864 LBS - 5952 LBS)
Permissible load on rear axle	*2660 kg - 2700 kg (5864 LBS - 5952 LBS)
Permissible supporting load on trailer hitch	800 kg (1764 LBS)

\* With 33x12.50 R15 tires

Accessories	Total	Front	Rear
Creep speed gear	13 kg (28.6 LBS)	10 kg (22 LBS)	3 kg (6.6 LBS)
Rear lift	77 kg (169.7 LBS)	-25 kg (-55 LBS)	102 kg (224.8 LBS)
Loading platform	75 kg (165.3 LBS)	0 kg (0 LBS)	75 kg (165.3 LBS)

### Weights w/o loading platform and rear lift

Tires	36x13.5-15		10.5-18 MPT 400/60-15.5		33x12.50 R15		33x12.50-15		31x15.50-15 33x15.50-15		33/18LL-16.1	
	C9700 C9.72	C9700H C9800H C9.72H C9.78H C9.83H C9.88H	C9700 C9.72	C9700H C9800H C9.72H C9.78H C9.83H C9.88H	C9700 C9.72	C9700H C9800H C9.72H C9.78H C9.83H C9.88H	C9700 C9.72	C9700H C9800H C9.72H C9.78H C9.83H C9.88H	C9700 C9.72	C9700H C9800H C9.72H C9.78H C9.83H C9.88H	C9700 C9.72	C9700H C9800H C9.72H C9.78H C9.83H C9.88H
Empty weight (incl. driver 75 kg)												
Total: kg	2430 (5351)	2620 (5776)	2440 (5319)	2630 (5198)	2390 (5269)	2580 (5687.8)	2380 (5246.9)	2570 (5665.8)	2410 (5313.1)	2600 (5732)	2470 (5445.4)	2660 (5864.2)
Front: kg	1275 (2810.8)	1390 (3064.4)	1280 (2821.8)	1395 (3015)	1255 (2766.7)	1370 (3020.3)	1250 (2755.7)	1365 (3009.3)	1265 (2788.8)	1380 (3042.3)	1295 (2855)	1410 (3108.5)
Rear: kg	1155 (2546.3)	1230 (2711.6)	1160 (2551.3)	1235 (2122.6)	1135 (2502)	1210 (2667.5)	1130 (2491.2)	1205 (2656.5)	1145 (2524.3)	1220 (2689.6)	1175 (2590.4)	1250 (2755.7)

**Technical data****Tires**

Type of Tire	Ply	Profile	Tube	Inflation Pressure	Wheel Weights	
					Type	Weight
10.5-18 MPT S	6	Cleat profile	yes	1.5 bar (22 PSI)	524-34-1	approx. 45 kg (100 LBS)
10.5-18 MPT	6	Cleat profile	yes	1.5 bar (22 PSI)	524-34-1	approx. 45 kg (100 LBS)
31x15.50-15	8	Profile	no	2.0 bar (14-29 PSI)	524-34-1	approx. 45 kg (100 LBS)
33x15.50-15	4	Profile	no	1.0 bar (14.7 PSI)	524-34-1	approx. 45 kg (100 LBS)
33x12.50-15	6/8	(M+S)/Profile	no	1.4 bar (20 PSI)	524-34-1	approx. 45 kg (100 LBS)
33x12.50-R15	6	M + S	no	1.6 bar (23 PSI)	524-34-1	approx. 45 kg (100 LBS)
36x13.50-15	4	Lawn	no	1.0 bar (14.7 PSI)	524-34-1	approx. 45 kg (100 LBS)
400/60-15.5	6	Profile	yes	1.8 bar (26 PSI)	524-34-1	approx. 45 kg (100 LBS)
33/18LL-16.1	10	Lawn	no	1.2 bar (17 PSI)	524-34-1	approx. 45 kg (100 LBS)

NOTE: Observe prescribed inflation pressure with maximum axle load and when driving on roads.

**Engine Specifications**

	<b>C 9700/9.72 C 9700/9.72H</b>	<b>C 9800/9.73H</b>	<b>C 9.78H</b>	<b>C 9.88H</b>
Manufacturer	Deutz AG	Deutz AG	Deutz AG	Deutz AG
Type	BF4M1011	BF4M1011F	BF4M2011	BF4M2011
Mode of operation	Four-stroke Diesel	Four-stroke Diesel	Four-stroke Diesel	Four-stroke Diesel
Number of cylinders	4	4	4	4
Cubic capacity	2914	2914	3108	3108
Fuel consumption	223g/KW-h at 1500-1750 rpm	222g/KW-h at 1750-1850 rpm	216g/KW-h at 1750-1850 rpm	216g/KW-h at 1550-1650 rpm
Rated speed	2500 rpm	2600 rpm	2500 rpm	2800 rpm
Maximum idling speed	2600 rpm	2750 rpm	2750 rpm	3050 rpm
Minimum idling speed	900 rpm	900 rpm	900 rpm	900 rpm
Power at n=2800 rpm	53.5 KW (72 HP)	61 KW (83 HP)	57 KW (78 HP)	65 KW (88 HP)

## Technical data

### Theoretical Driving Speeds

Transmission		Unit	Gearbox	Hydrosta- tic Drive	Hydrosta- tic Drive	Hydrosta- tic Drive	Dual Drive	Dual Drive	Dual Drive
Engine Output		kW	53.5	53.5 57	61	65	53.5 57	61	65
Engine speed		rpm	2500	2500	2600	2800	2500	2600	2800
Tires	Type								
36x13.50-15	524-31-8	km/h	36.8	30.8	32.0	34.4	38.4	39.9	43.0
10.5-18 MPT	524-31-1/-6	km/h	35.9	30.1	31.3	33.7	37.6	39.1	42.1
400/60-15.5	524-31-5	km/h	34.1	28.6	29.7	32.0	35.7	37.1	40.0
33x12.50 R15	524-31-7	km/h	33.3	27.9	29.0	31.2	34.8	36.2	39.0
33x12.50-15	524-31-4	km/h	32.4	27.2	28.3	30.4	33.9	35.3	38.0
33x15.50-15	524-31-3	km/h	32.4	27.2	28.3	30.4	33.9	35.3	38.0
33/18LL-16.1	524-31-9	km/h	31.8	26.7	27.8	29.9	33.3	34.7	37.3
31x15.50-15	524-31-2	km/h	30.5	25.1	26.1	28.1	31.3	32.6	35.1



## Technical Data/Filling Quantities

Assembly	Suppl. Information	Description
<b>Mechanical gearbox</b>		16 forward gears/16 reverse gears with planetary axles
<b>Hydrostatic drive</b>		Infinitely variable driving speed, 2 mechanical speed ranges
Power take-offs		2 PTOs (front and rear) Rotating Direction: clockwise when looking at end of shaft
- RPM, front		540 rpm at 2200 engine rpm, 1000 rpm at 2390 engine rpm
- RPM, rear		1000 rpm at 2360 engine rpm
- Wedge shaft profile		1 3/8 " (6) DIN 9611
PTO clutch		Multiple disk wet clutch
Differential lock		Acts simultaneously on front and rear axles
<b>Fuel system</b>		
Fuel tank	Diesel fuel	86 l (22.7 USGAL.)

## Technical data

Assembly	Suppl. Information	Description
<b>Steering</b>		
- Type		Hydrostatic with 2 double-acting steering rams
- Steering valve		Orbitrol OSPC 125 LS
<b>Brakes</b>		
- Service brake		Multiple-disk brakes, wet, acting on all 4 wheels
- Activation		Hydraulic
- Parking brake		Multiple-disk brakes, wet, acting on all 4 wheels
- Activation		Mechanical
<b>Trailer hitch</b>		
- Make		Cramer, height-adjustable
<b>Front lift</b>		
- Make		3-point, upper link adjustable
- Mounting		Category I and II
- Lifting power		27000 N (measured at installation points)
- Cylinders		2 double-acting cylinders

Assembly	Suppl. Information	Description
<b>Rear lift</b>		
- Model		HOLDER 3-point standard
- Mounting		Category I and II
- Lifting power		15700 N (at installation points)
- Cylinders		2 double-acting cylinders
<b>Drive Hydraulics</b>		
Variable pump		Hydromatik
- Model		A11 VG 50 EP / A4 VG 40 EP
- Flow rate		160 l/min (42 GAL/MIN)
- Operating pressure		300 bar (4410) (max. 350 bar (5145)) / 380 bar (5586) (max. 430 bar (6320))
Variable motor		Hydromatik
- Model		A6 VM 55 EP
- Displacement		26.1 - 55 cm <sup>3</sup> /rev
Hydraulic oil tank		19 l (5.02 GAL.)

## Technical data

Assembly	Suppl. Information	Description
<b>Hydraulics for implements (with steering)</b>		
Pump		Sundstrand
- Make		-
- Flow rate		17 cm <sup>3</sup> /rev (42.5 l/min at 2500 engine rpm)
- Operating pressure		180 -190 bar
Hydraulic oil tank		22 l (5.8 GAL.)
<b>Electrical System</b>		
- Operating voltage		12 VDC
- Battery		12 V / 88 Ah
- A/C alternator		14 V / 60 A
- Starter		12 V / 2.4 kW
<b>Whole Vehicle</b>		
- Ambient temperature range		- 30° to + 50°C

**Noise Level**

The tractor emits the following noise level (measured at the driver's ear) according to EU Standard 77/311/EEC; measurement according to Appendix II.

**Table of Noise Levels and Absorption Rating**

Model	Engine Type	Engine Output	Noise Level dB(A)		Absorption rating
			Cabin open*	Cabin closed	
C 9700	BF4M1011	53.5 kW (72 HP)	79	78	2.1
C 9700 H	BF4M1011	53.5 kW (72 HP)	79	78	2.1
C 9800 H	BF4M1011F	61 kW (83 HP)	79	78	2.1
C 9.72	BF4M1011	53.5 kW (72 HP)	79	78	2.1
C 9.72 H	BF4M1011	53.5 kW (72 HP)	79	78	2.1
C 9.83 H	BF4M1011F	61 kW (83 HP)	79	79	2.1
C 9.78 H	BF4M2011	57 kW (78 HP)	79	79	1.8
C 9.88 H	BF4M2011F	65 kW (88 HP)	79	79	2.0

\*Roof vent and side window open

**Exhaust Gas Identification**

The absorption rating is stated on the identification plate.

### Description

#### Views of Tractor

##### Front Left View

- 1 Turn signal, position light
- 2 Headlight, top
- 3 Driver's cab
- 4 Dumpbody (dump)
- 5 Rear of vehicle
- 6 Engine oil dipstick
- 7 Battery isolating switch
- 8 Rear axle
- 9 Hydraulic oil tank and filler neck (drive hydraulics)
- 10 Front axle
- 11 Hydraulic couplings for implements\*
- 12 Front lift - lower link support
- 13 Upper link support
- 14 Headlight
- 15 Windshieldwiper/washer

\* Option



### Tractor

#### Rear Right View

- 1 Dump Body
- 2 Fuel filler neck
- 3 Oil filler neck for implement hydraulics
- 4 Intake screen for fresh air blower
- 5 Support for rotating beacon
- 6 Floodlight\*
- 7 Driver's cab
- 8 Front part of tractor
- 9 Front axle
- 10 Intake screen for drive oil cooler
- 11 Air vent for drive oil cooler
- 12 Oil level gauge for implement hydraulics and steering
- 13 Rear axle
- 14 Hydraulic couplings for implements\*
- 15 Trailer hitch
- 16 Socket for trailer lighting
- 17 Tail light, LH/RH

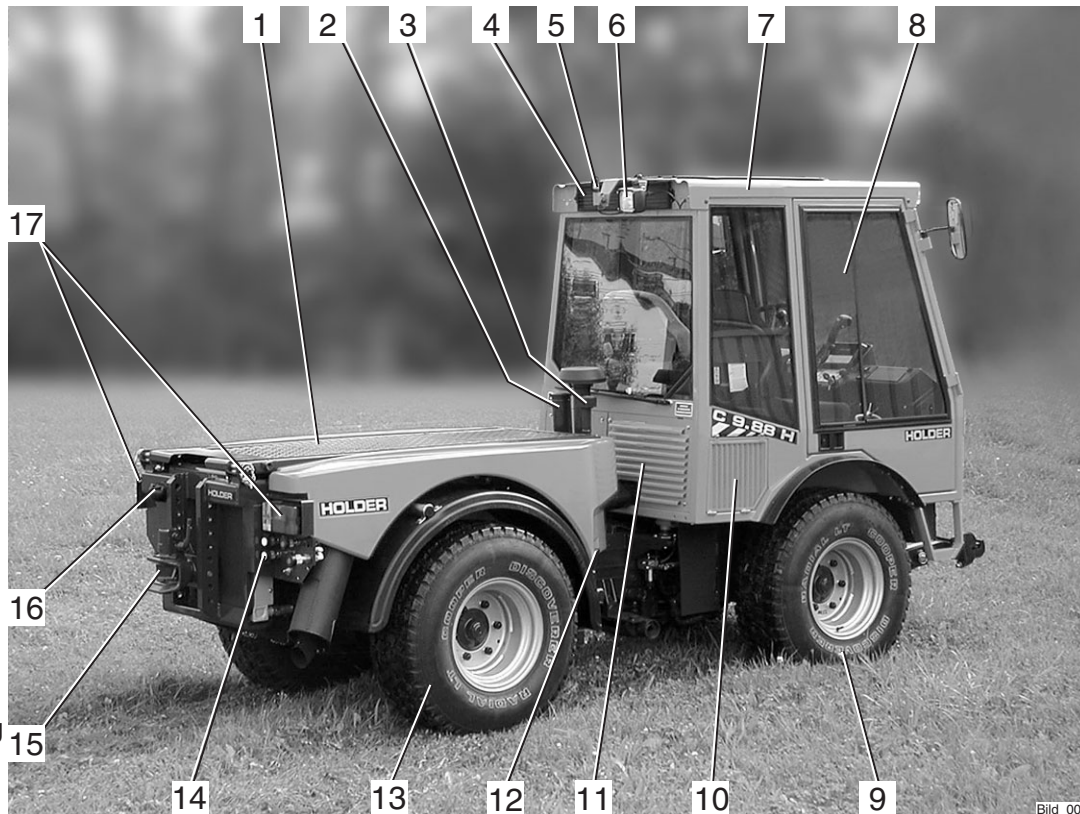

Bild\_002

\* Option

## Description

### Driver's Station

#### Operating controls

- |    |   |    |  |
|----|---|----|--|
| 1  | Light switch  | 15 | Tilt lock switch*  |
| 2  | Differential lock switch                                    | 16 | Preheat/starter switch   |
| 3  | Pressure gauge for hydraulic carrier*                       | 17 | Hydraulic carrier* control   |
| 4  | Steering wheel  | 18 | Passenger seat<br>(water reservoir for windshield washer system is located under the seat) |
| 5  | Brake fluid reservoir                                       | 19 | Parking brake lever  |
| 6  | Control lever for dump support*                             | 20 | Driver's seat<br>(warning triangle is mounted behind the seat)                             |
| 7  | Implement* control lever                                    | 21 | Accelerator pedal  |
| 8  | Multi-function display                                      | 22 | Steering wheel tilt adjustment knob  |
| 9  | Multi-function lever* (front lift and direction of travel)  | 23 | Driving program switch   |
| 10 | Digital instrument switch (ground speed in km/h or PTO rpm) | 24 | Inch knob for ground speed   |
| 11 | Hazard warning flasher switch                               | 25 | Turn signal lever  |
| 12 | Heater fan switch   |    |  |
| 13 | Power Socket  |    |  |
| 14 | Implement lock switch*                                      |    |  |

\* Option





### Description

#### Implement\* and Engine Controls (Details)

- 1 Control lever for dump/rear lift\*
- 2 Control lever functions plate
- 3 Multi-function lever functions plate
- 4 Multi-function lever\* (front lift and travel direction)
- 5 Hand throttle
  - Outer ring for fine adjustment:  
Turn clockwise to decrease rpm  
Turn counter-clockwise to increase rpm
  - Inner knob for coarse adjustment:  
Pull out to increase rpm  
Push in to decrease rpm  
Push in fast for emergency reset to idling rpm
- 6 Preheat/starter switch
- 7 Lock knob for longitudinal motion of multi-function lever:
  - Depressed - locked
  - Centre position - free movement
  - Pulled out - float position
- 8 Lock knob for lateral motion of multi-function lever
- 9 Lock knob for longitudinal motion of control lever
- 10 Lock knob functions plate

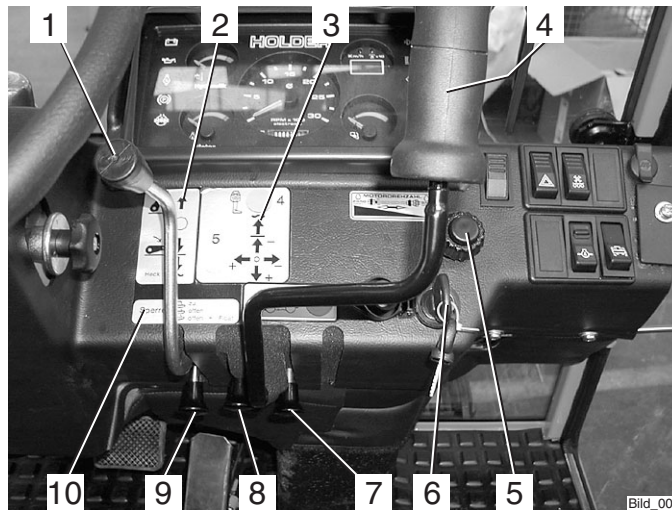

\* Option

## Description

### Multi-function Lever



#### **NOTE**

*Various types of multi-function levers can be installed.*

### Multi-function Lever (Variant 1)

- 1 Multi-function lever without forward reverse selector lever (Forward-reverse selector installed on instrument board)
- 2 Forward/reverse selector lever
- 3 Note plate  
Driving direction

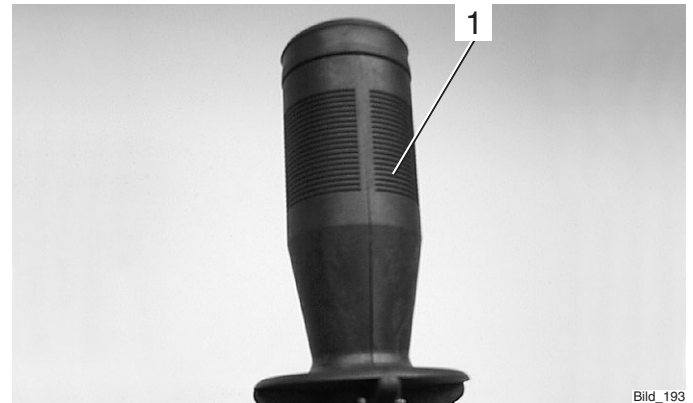

Bild\_193

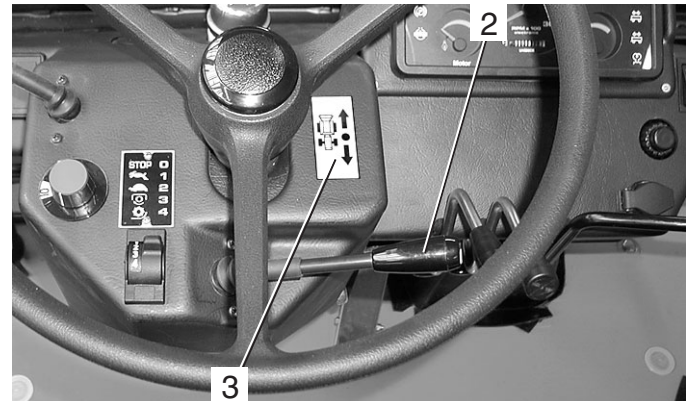

## Description

### Multi-function Lever\* (Variant 2)



#### NOTE

The coloured buttons control the function of the implements attached to the related hydraulic couplings

- 1 Multi-function lever
- 2 Blue hydraulic couplings on
- 3 Blue hydraulic couplings off - float position
- 4 LED indicator, red or green
- 5 Functions off
- 6 LED indicator, red
- 7 Functions on
- 8 LED indicator, red
- 9 LED indicator, red or green
- 10 Yellow hydraulic couplings, off
- 11 Green hydraulic couplings off - float position
- 12 Green hydraulic couplings on
- 13 Yellow hydraulic couplings on

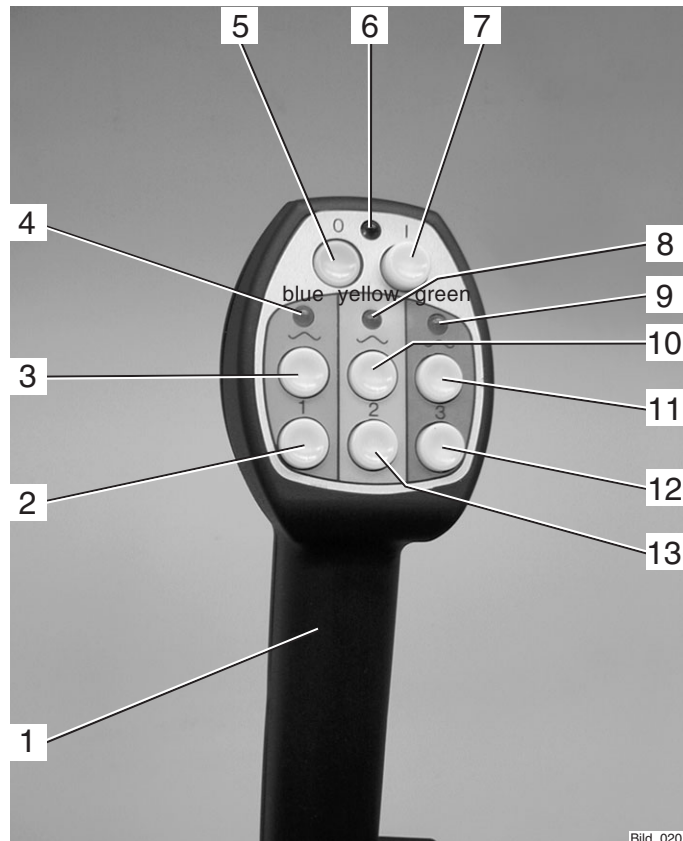

\* Option

**Description****Multi-function Lever\* (Variant 3)**

- 1 Forward direction arrow (illuminated if selected)
- 2 Reverse direction arrow (illuminated if selected)
- 3 Forward/reverse selector switch (left for forward - right for reverse)
- 4 Multi-function lever

**Multi-function Lever\* (Variant 4)**

- 1 Forward direction arrow (illuminated if selected)
- 2 Reverse direction arrow (illuminated if selected)
- 3 Forward/reverse selector switch (left forward - right reverse)
- 4 Front lift float position pushbutton
- 5 Multi-function lever
- 6 Front lift pushbutton
- 7 Yellow pushbutton, left (front when looking forward) (movements at yellow hydraulic couplings on)
- 8 Yellow pushbutton, right (front when looking forward) (movements at green hydraulic couplings on)

\* Option

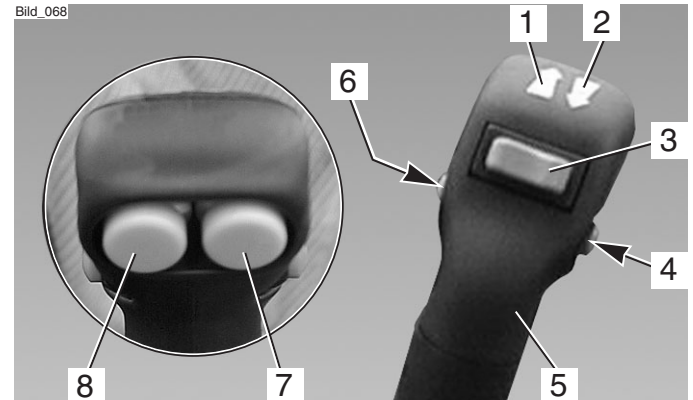
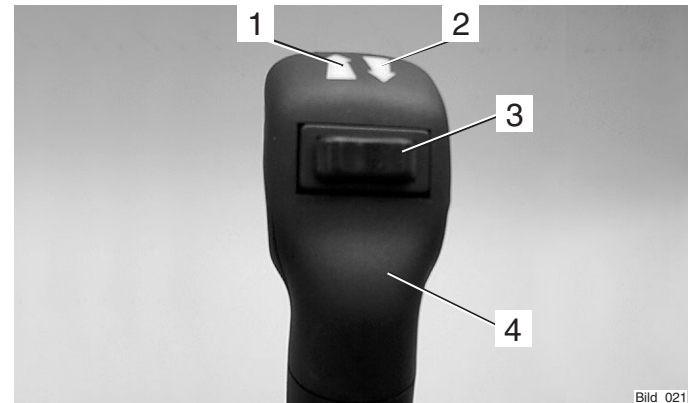

## Description

### Foot Pedals

- 1 Inch pedal (clutch pedal if gearbox is fitted)
- 2 Brake pedal
- 3 Accelerator pedal

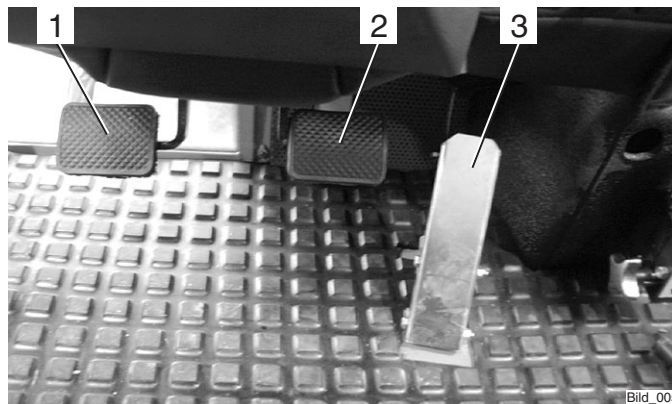

### Hydraulic Carrier\* Control (Power Lifter)

- 1 Pressure adjuster
- 2 ON-OFF label
- 3 Star knob for turning on/off

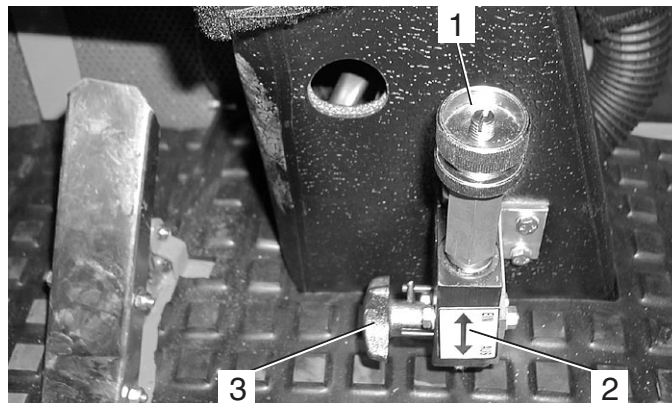

\* Option

**Description****Operating Controls Behind the Seat**

- 1 PTO clutch lever, ON-OFF
- 2 Device selector lever:
  - Position for dump on
  - 3 - Position for rear lift on
- 4 Emergency start  
(Hydrostatic Drive with Dual-Drive only)

**Drive Range Pre-selection Lever between Seats**

- 1 Drive range pre-selection lever
- 2 Drive range label
  - Position S - Fast Driving range (low tractive force)
  - Centre position 0 - Drive off - Towing
  - Position L - Slow Working range (high tractive force)



Bild\_069

### Taking into Service

#### Front PTO Selector

- 1 PTO rpm label
  - Top position (up) - 540 rpm
  - Centre position - Neutral
  - Lower position (down) - 1000 rpm
- 2 PTO selector lever

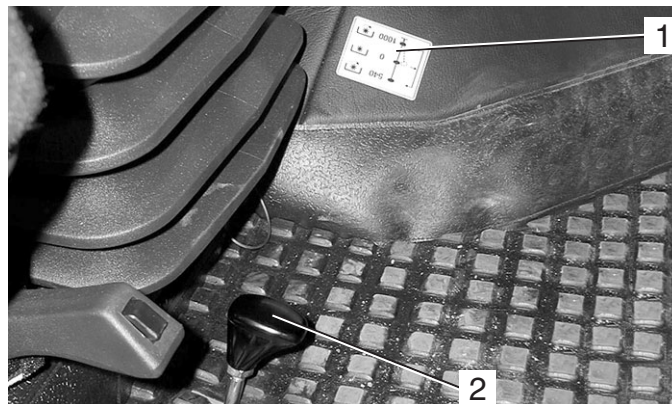

#### Heater

- 1 Heater temperature control
- 2 Heating temperature label
  - lever up - warmer
  - lever down - cooler

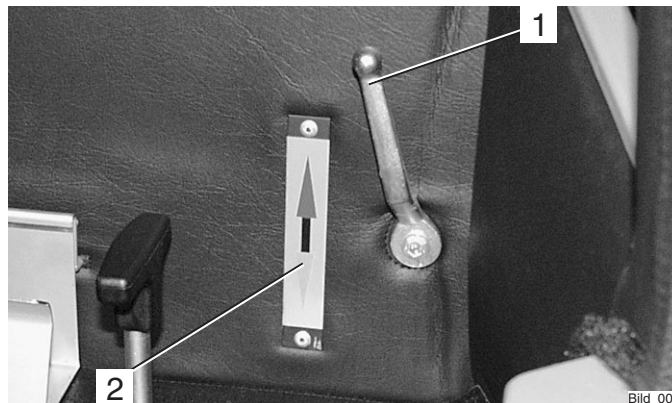

Bild\_009



## Taking into Service

### Legend for Multi-function Display

- 1 Display for
  - Ground speed in km/h or
  - PTO rpm x10
- 2 Position light indicator
- 3 High beam indicator
- 4 Turn signal indicator
- 5 Turn signal indicator for trailer 1
- 6 Turn signal indicator for trailer 2
- 7 Preheating indicator
- 8 Fuel gauge
- 9 Hour meter
- 10 Tachometer
- 11 Engine temperature gauge
- 12 Spare
- 13 Differential lock engaged indicator
- 14 Parking brake engaged indicator
- 15 Engine oil temperature indicator
- 16 Engine oil pressure indicator
- 17 Battery charge indicator
- 18 Hydraulic oil temperature gauge

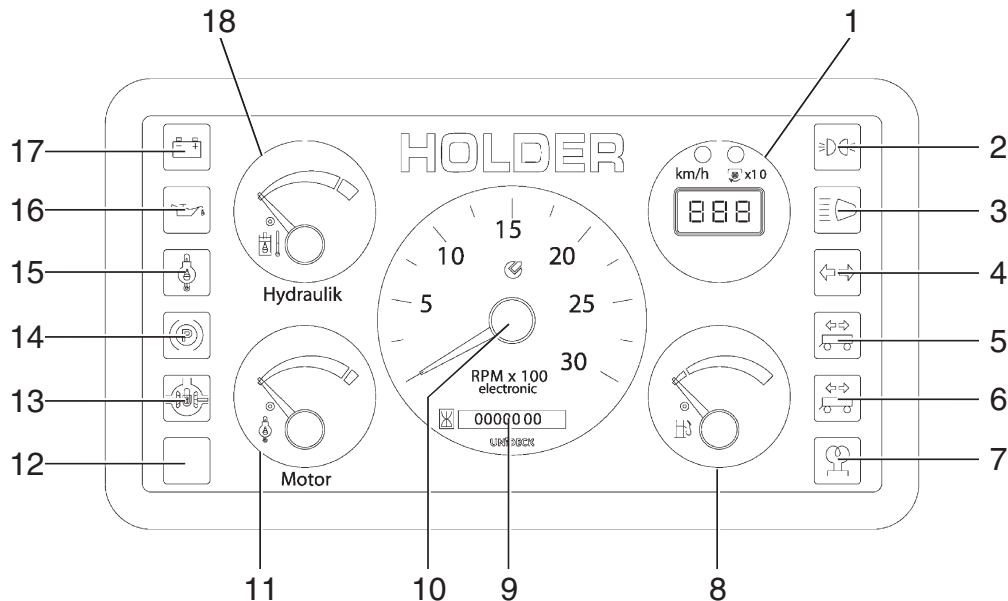

## Description

### Controls for Mechanical Gearbox

- 1 Gearshift lever (left looking forward) with 4 synchronized gears 1-2-3-4
- 2 Range selector lever (right looking forward) with 4 speed ranges:  
S - Highway driving  
M - Medium speed  
L - Slow speed  
LL - Very slow speed
- 3 Gearshift label

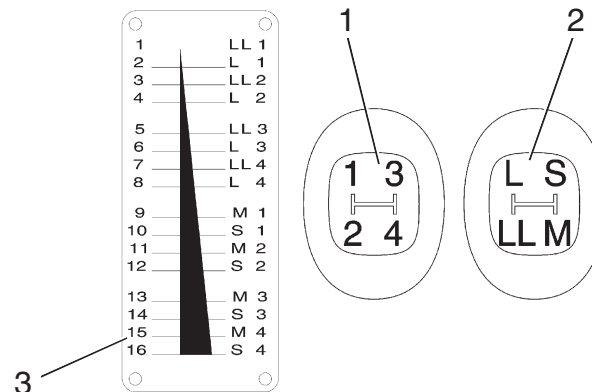
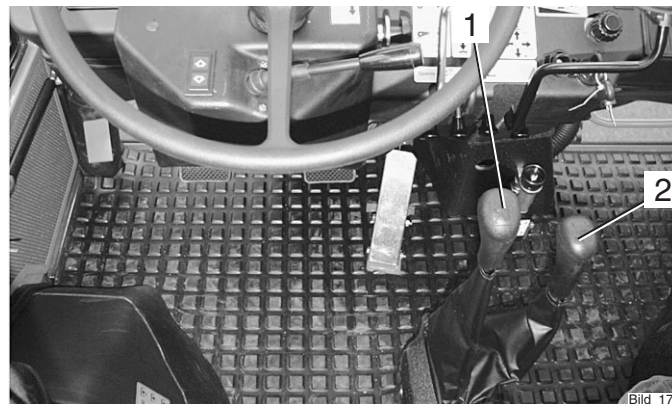

Bild\_017

## Description

### Controls on Cabin Console at Front Left

- 1 Front wiper/washer switch
- 2 Rear wiper/washer switch
- 3 Sun blind
- 4 Air vent nozzle

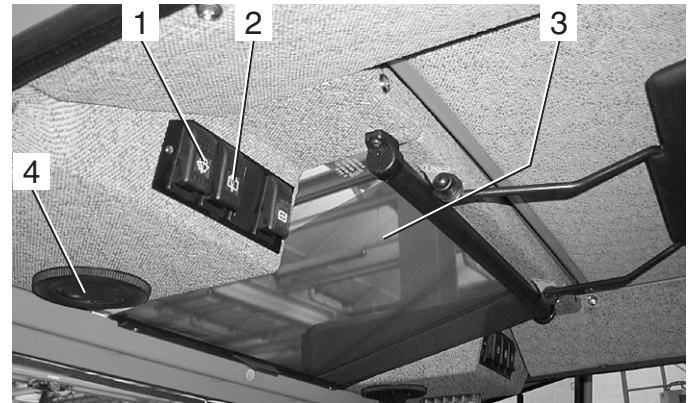

### Controls on Cabin Console at Front Right

- 1 Rotating beacon switch
- 2 Fresh air blower switch, top
- 3 Headlight switch, top
- 4 Rear floodlight switch
- 5 Air vent nozzle

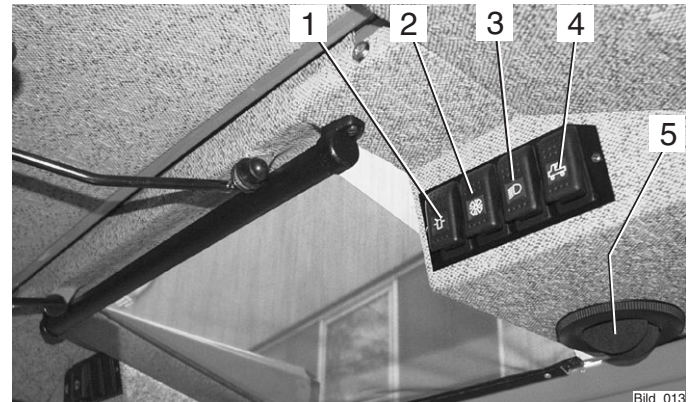

Bild\_013

### Description

#### Controls in Cabin at Rear

- 1 Interior light
- 2 Sun visor
- 3 Roof hatch handle
- 4 Roof hatch

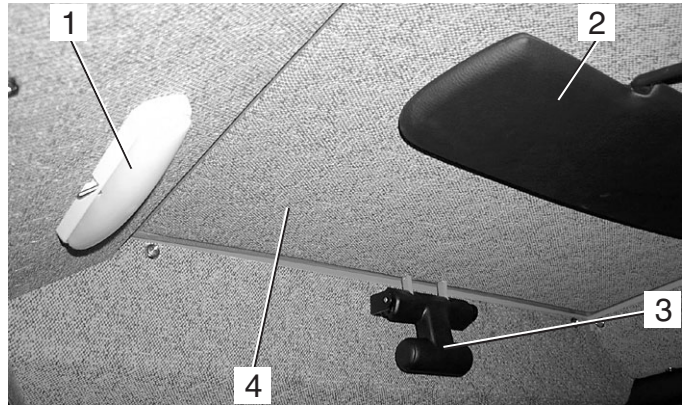

### Location of Plates and Labels

#### Identification Plates

- 1 Variable motor type plate
- 2 Engine type plate
- 3 Variable pump type plate
- 4 Machine type plate
- 5 Chassis Serial Number  
(on front RH support looking forward)
- 6 Cabin type plate

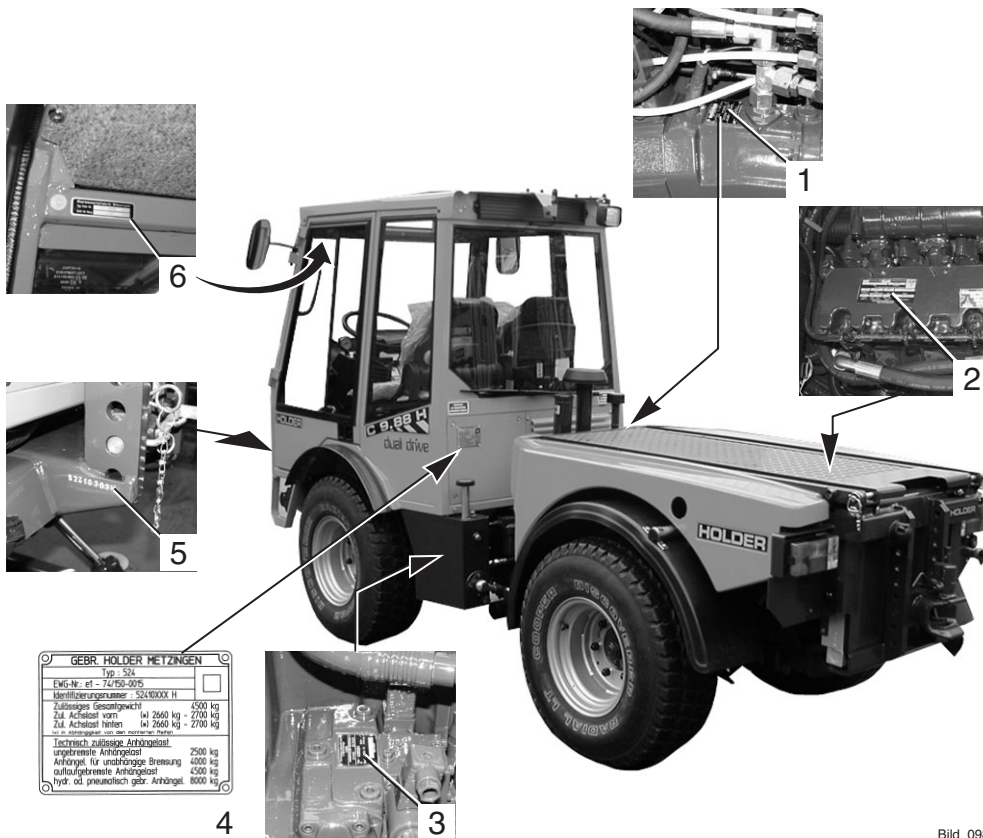

Bild\_098

## Description

### Mounting Instructions for License Plate

- Install the front license plate (1) above the upper link support at the front cabin wall.
- Install the rear license plate (2) at the rear below the left tail light.

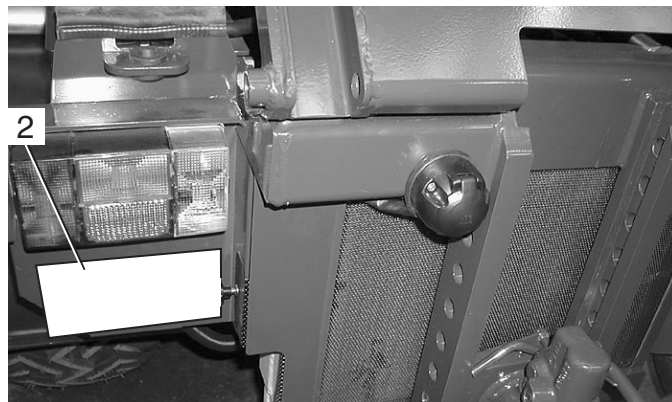
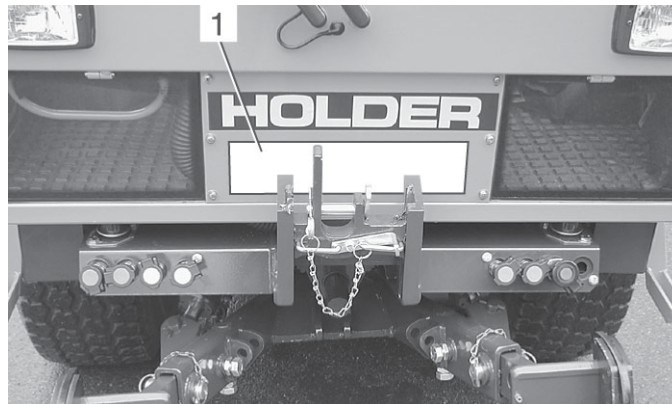

**Overview of Options and Variants**

<b>Assembly</b>	<b>Suppl. Information</b>	<b>Dimension /Order No./Type</b>
Charcoal filter	For cabin ventilation	131667
Pneumatic braking system	For trailer operation	526-34-60, 524-34-63
Rear lift		524-51-4
Oil heating element	from - 20°C	230 VAC
Hydraulic carrying equipment (power lifter)		524-80-19
Creep speed gearbox with hand lever	Super For mechanical gearbox only	5262-11, 524-62-70
Variable pump for implements	0-100 l /min adjustable	524-80-34
- Pump		
- Delivery capacity		0-40 cm <sup>3</sup> /rev
- Flow rate		0-100 l/min
- Maximum pressure		280 bar

**Description**

<b>Assembly</b>	<b>Suppl. Information</b>	<b>Dimension /Order No./Type</b>
Power hydraulics	75 l/min fixed displacement	524-80-35
- Pump	Mounted on drive pump	Gear pump
- Delivery capacity		22 cm <sup>3</sup> /rev
- Flow rate		75 l/min
- Maximum pressure		210 bar
<hr/>		
Flow divider I. Circuit		524-80-25
- Pump	Standard pump	
- Delivery capacity		17 cm <sup>3</sup> /rev
- Flow rate		0-25 l/min
- Maximum pressure		200 bar
<hr/>		
Flow divider II. Circuit		524-80-47
- Pump	Tandem pump	
- Delivery capacity		14 cm <sup>3</sup> /rev
- Flow rate		0-25 l/min
- Maximum pressure		200 bar



**Description**

<b>Assembly</b>	<b>Suppl. Information</b>	<b>Dimension /Order No./Type</b>
Circulating oil device	rear, uncontrolled	524-80-45
- Pump	Tandem pump	
- Delivery capacity		14 cm <sup>3</sup> /rev
- Flow rate		35 l/min
- Maximum pressure		200 bar
Reduction gearbox	Reduction of rear PTO rpm to 540 rpm	526-62-1

## Description

### Accessories

The tractor is delivered with the following accessories:

- 1 Operating Instructions
- 2 Bio-Pass for certification of filling with environment-friendly hydraulic oil
- 3 Key holder
- 4 2 ignition keys
- 5 4 door keys
- 6 Upper link
- 7 2 reducers for category II implements

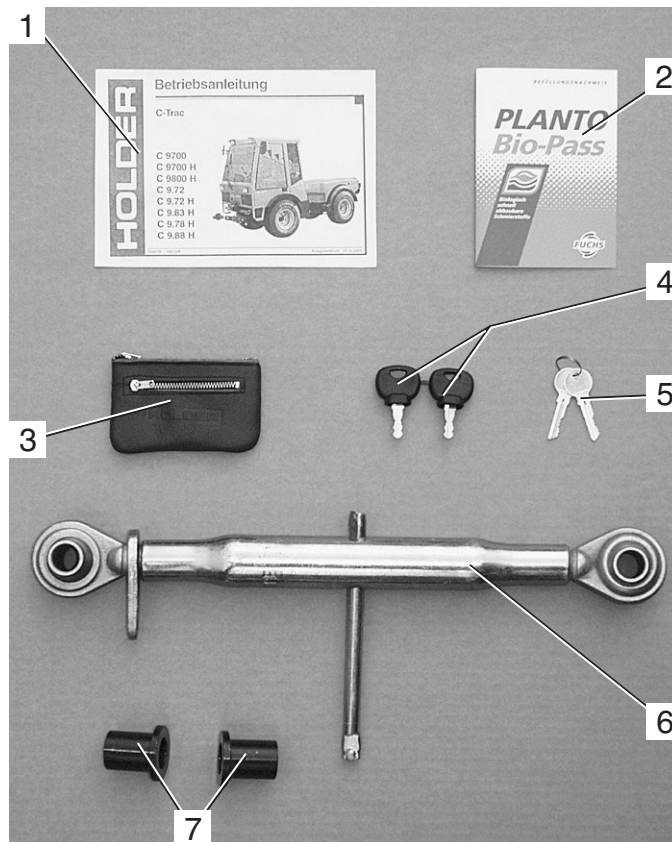

## Taking into Service

### Daily Checks and Activities before Taking into Service

If damages or defects are found during the following checks, they must be eliminated before taking the vehicle into service. Do not operate the tractor before proper repairs are carried out. Safety and protective devices should not be removed or disabled. Fixed specified settings may not be changed.

Before starting work, make yourself familiar with all the functions and protective devices of the tractor.

### Checking and Cleaning the Cooler and Radiator Screen Guards



#### NOTE

- Check if the mud guards (2, 3, 4, 5 and 6) are clean.
- Clean the mud guards if necessary. The guard (6) can be pulled out laterally to the left after releasing the bayonet screw (7) and then cleaned easily.
- The air intake of the air filter (1) must be clean.

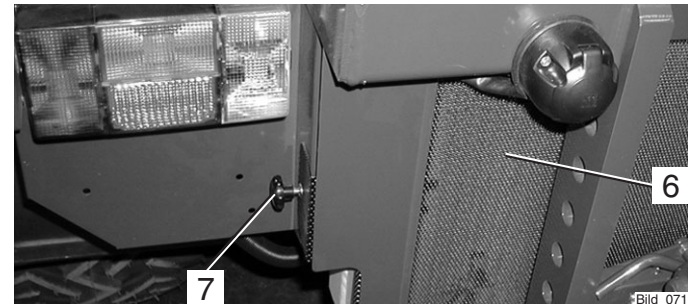
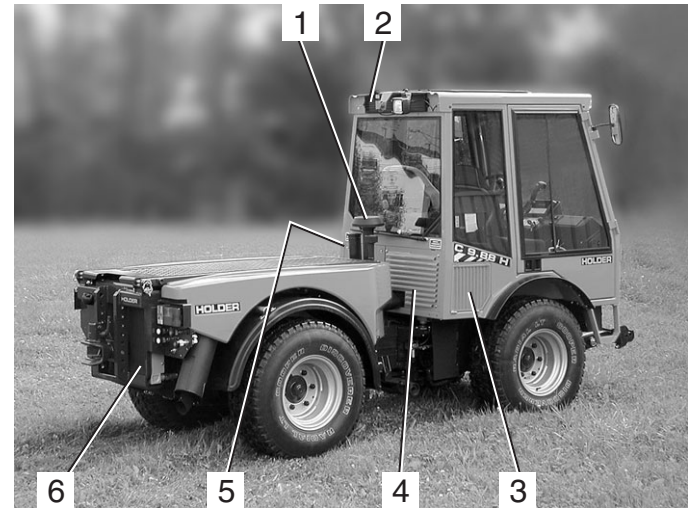

Bild\_071

### Taking into Service

#### Turning on the Battery Isolating Switch



##### NOTE

The battery can be switched off completely with the removable key.

- Insert the key (1) in the battery isolating switch and set it to the vertical position.  
The battery circuit is turned on.

#### Checking Engine Oil Level



##### NOTE

Check the engine oil level only when the tractor is on level ground.

- Let the engine run approx. 2 minutes with the heat shut-off valve open.
- Stop the engine and pull the oil dipstick (1) out after approx. 1 minute.
- The oil level should be between the Min (2) and Max marking (3).
- If necessary, fill oil according to the maintenance manual.



##### ATTENTION

Do not fill too much oil.

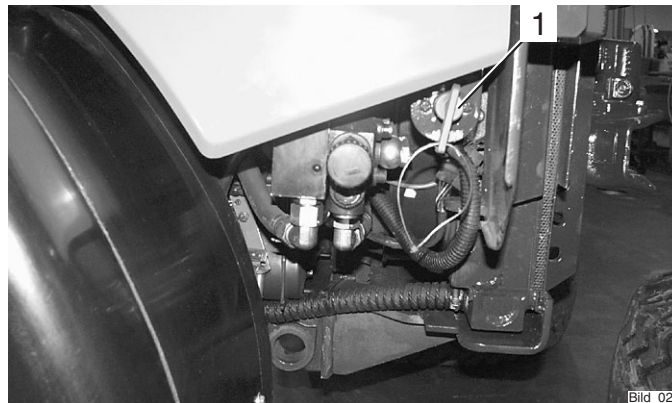

Bild\_022

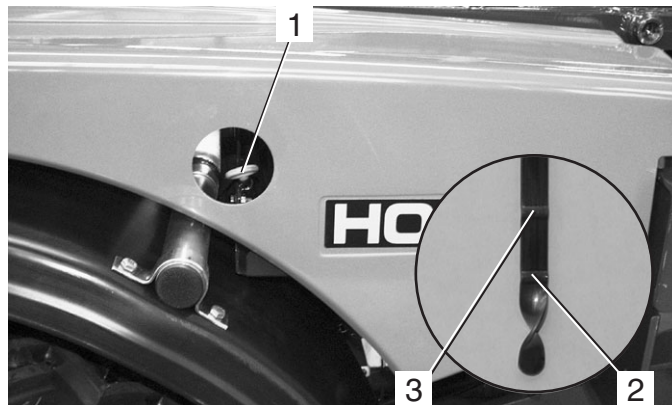

### Checking the Trailer Hitch (Optional), if required

- Check the trailer hitch for proper condition and working. Carry out the check according to the instructions in the section "Operating the Trailer Hitch".

### Checking Tire Inflation Pressure



#### **NOTE**

Your tractor can be equipped with different types of tires. The specified inflation pressure for your tires is given in the table entitled "Tires" in the technical data section.

- Check the inflation pressure of all four tires. All tires must have the same pressure. If the pressure is too low, the rolling resistance increases. This causes an increase in fuel consumption and tire wear, the driving characteristics become poorer.



#### **DANGER**

If the inflation pressure is too high, the tires can explode.

- The tires should not be damaged or worn.
- Have damaged tires replaced without delay. Due to the longer braking distance the risk of an accident is increased.

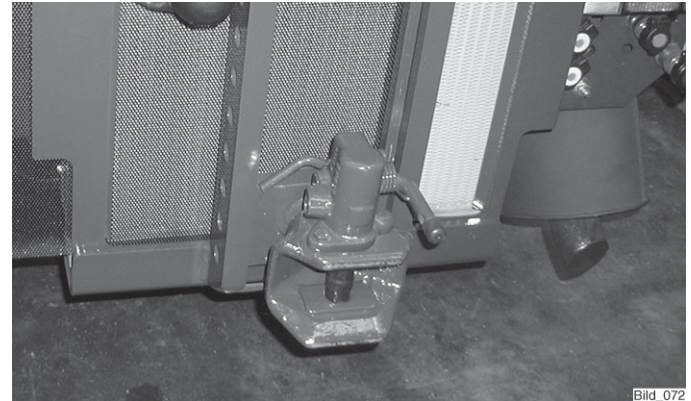

Bild\_072



### Taking into Service

#### Checking the Drive Hydraulics Oil Level

- Withdraw the oil dipstick (1).
- The oil level must be at the marking (2).
- Top up oil as specified in the maintenance manual.



Bild\_026

#### Checking the Implement Hydraulics Oil Level

- Retract all hydraulic cylinders.
- Check the oil level at the sight glass (2).  
The oil level must be at the centre (1) of the sight glass.
- Top up oil as specified in the maintenance manual.

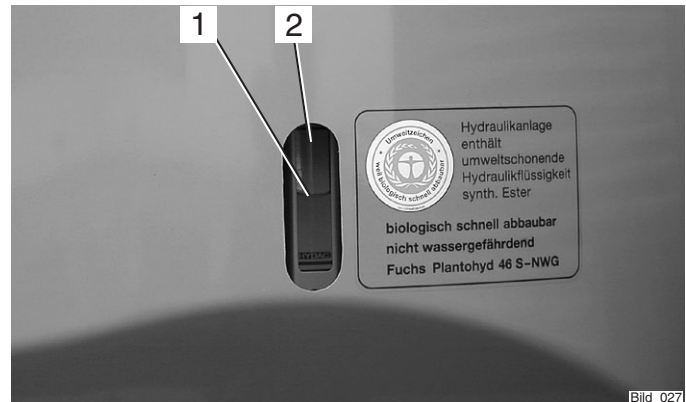

Bild\_027

**Taking into Service****Filling Fuel**

- If necessary, read the fuel level (1) on the multi-function display.

**CAUTION**

*Danger of fire when handling fuels. Turn off the engine. Do not fill any fuels in the vicinity of naked flames, ignition sparks or hot engine parts. Do not smoke during refuelling.*

- Remove the fuel tank filler cap (2).
- Top up Diesel fuel as specified in the maintenance manual.

**Filling quantities ..... approx. 86 litres (22.7 USGAL.)**

- Refit the filler cap (2).

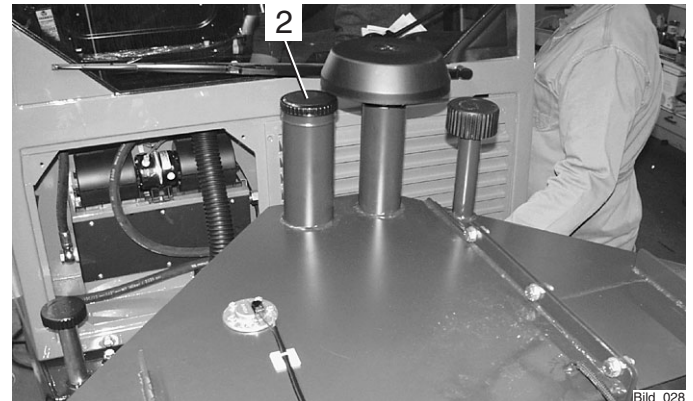
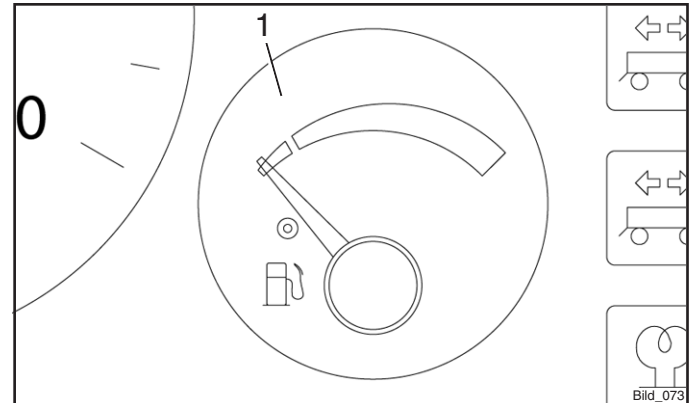

### Taking into Service

#### Checking the Brake Fluid Level

- Check the brake fluid level at the brake fluid reservoir (2).
- The brake fluid level must be between the Min and Max marking at the reservoir.
- Top up the brake fluid as specified in the maintenance manual.

#### Adjusting the Steering Wheel



##### **NOTE**

*The tilt of the steering wheel can be set to a comfortable position.*



##### **DANGER**

*Do not adjust the steering wheel while driving.*

- Loosen the star knob (3).
- Pull the slider (4) to the right.
- Adjust the tilt of the steering wheel (1) and release the slider again.
- Retighten the star knob.

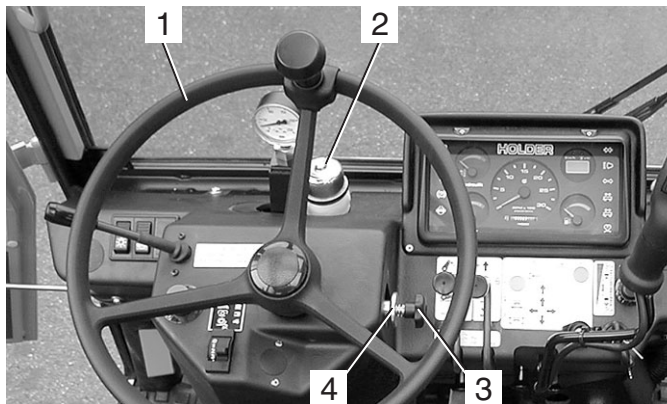



### Adjusting the Driver's Seat

- 1 Backrest
- 2 Adjustment knob for lumbar padding
- 3 Backrest adjustment
- 4 Weight adjustment
- 5 Horizontal cushioning
- 6 Horizontal adjustment



#### **DANGER**

*Do not adjust the seat while driving. Risk of accidents!*

- Adjust the seat so that all controls can be reached and operated safely.



#### **NOTE**

*Observe the operating manual for the seat supplied with your tractor.*

### Adjusting the Lumbar Padding

- Sit down on the seat and lean against the backrest (1).
- Turn the adjustment knob for lumbar padding (2) until the most comfortable position is reached.

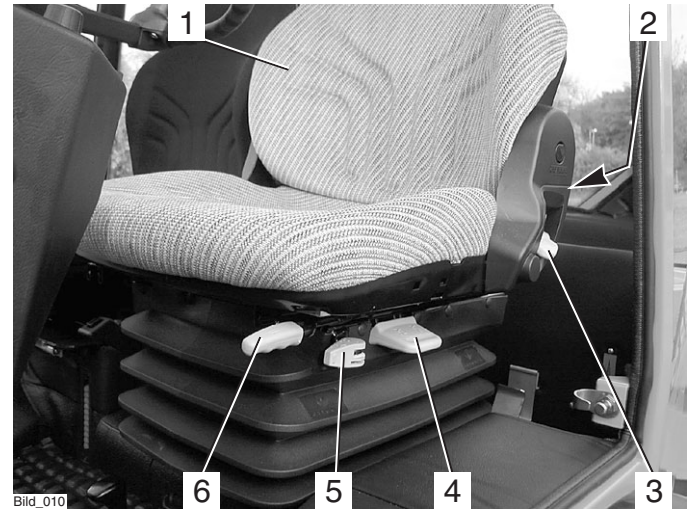

### Adjusting the Backrest

- Pull the tilt lever (3) up.
- Adjust the inclination of the backrest with your back.
- Release the tilt lever.

### Taking into Service

#### Adjusting the Driver's Weight

- Sit down on the driver's seat.
- Pull the weight adjustment handle (4) up.



#### NOTE

*An alert sounds. The seat is automatically set to the weight of the driver; The alert ceases.*

- Release the lever.

#### Adjusting the Horizontal Suspension

- Push the horizontal suspension lever (5) back: the seat suspension is unlocked in horizontal direction.
- Move the horizontal suspension lever (4) forward: the seat suspension is locked in the horizontal direction.

#### Adjusting the Seat Horizontally

- Pull the horizontal adjustment lever (6) up.
- Slide the seat horizontally forward or rear to the suitable seat position.
- Release the horizontal adjustment lever.

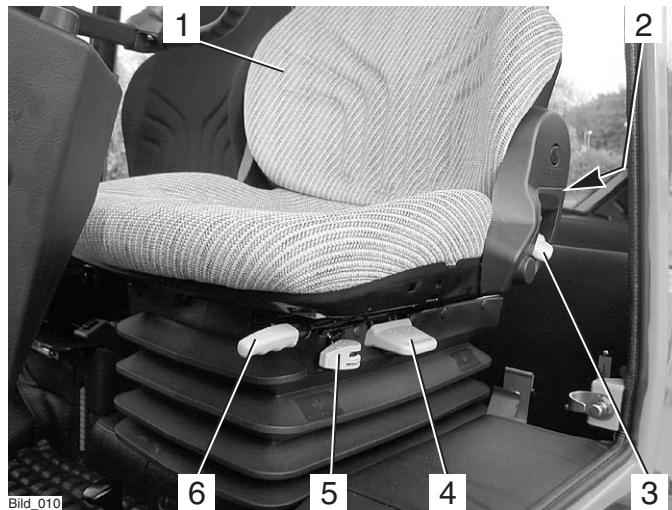

**Adjusting the Passenger Seat**

- 1 Backrest
- 2 Weight adjustment
- 3 Horizontal adjustment lever
- 4 Backrest tilt adjustment

**Adjusting the Weight**

- Sit down on the seat.
- Press the weight adjustment knob (2) from the top down until the weight is reached on the scale; The weight can be adjusted in 9 stages of 50 to 130 kg.
- Release the knob when your weight is indicated.

**NOTE**

*Only push the knob from the top down.*

- At the bottom press the knob against the stop - the weigh adjuster automatically resets the seat to 50 kg.
- Release the knob.

**Adjusting the Seat Horizontally**

- Pull the horizontal adjustment lever (3) up.
- Slide the seat horizontally forward or rear to the suitable seat position.
- Release the horizontal adjustment lever.

**Adjusting the Backrest Horizontally**

- Pull the tilt lever (4) up.
- Adjust the inclination of the backrest with your back.
- Release the tilt lever.



## Taking into Service

### Filling Washing Water



#### NOTE

*The washing water reservoir for the windshield washer is located beneath the passenger seat.*

- Tilt the seat forward.
- Open the filler cap (1) and add washing water into the reservoir (2).

**Filling capacity ..... approx. 2.5 litres (0.66 USGAL.)**

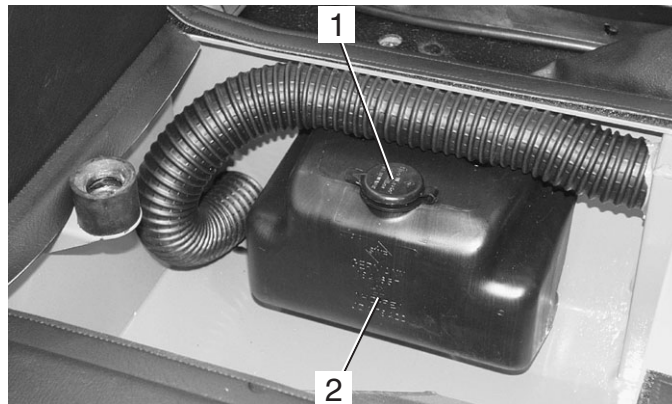

### Checking the Lights and Rear View Mirror

- Check that the lighting is functioning properly. Carry out the check according to the instructions in the section entitled "Lights".
- Adjust the rear view mirror so that the roadway behind the tractor and the working area are easily seen.

**Taking into Service**

**Starting the Engine**

**Instructions before Starting the Engine**



**DANGER**

*Do not start or run the engine in enclosed spaces. Danger of poisoning through exhaust gases!*

**Instructions before Starting**



**CAUTION**

*Before starting, check to ensure no one is in the vicinity of the tractor.*



**ATTENTION**

*Do not use a starting aid such as Startpilot or similar means. Turn off the drive or driven attaching implements.*



**CAUTION**

*Start the engine only from the driver's station.*

### Taking into Service

#### Starting the Engine

- Shift the gearshift lever (gearbox) to neutral.
- Set the forward/reverse selector lever (1) to the neutral position (centre).
- Depress the clutch pedal (gearbox) or inch pedal (hydrostatic drive).



#### NOTE

*The engine can only be started if the pedal is fully depressed (starting safety switch).*

- Set the hand throttle (2) to idle (push in fully).
- Insert the ignition key and turn the preheat/starter switch (3) to position 1.



Bild\_180

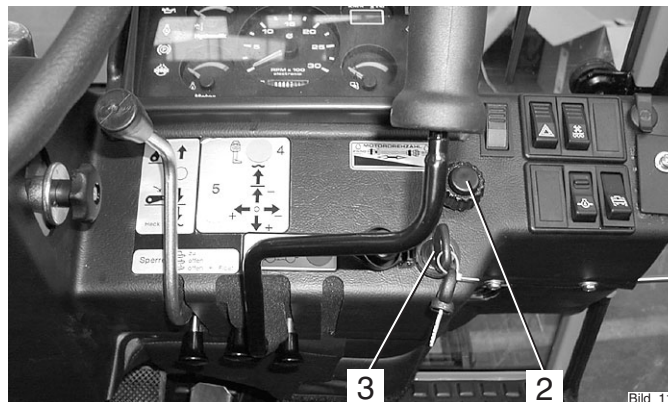

Bild\_113

**Taking into Service****NOTE**

The battery charge indicator (8), engine oil pressure indicator (7), parking brake indicator (6) (if parking brake is engaged) and the red indicator for km/h or x10 (3) in the multi-function display come on.

- Turn the ignition key to position 2 to preheat the engine. The preheating indicator (4) comes on.

**NOTE**

When starting at low temperatures, hold the ignition key longer (approx. 1 minute) in position 2.

- When the preheating indicator goes out, turn the ignition key to position 3 to start the engine.

**ATTENTION**

Operate the starter for a maximum of 20 seconds. Wait one minute, then repeat the starting procedure. Repeat the starting procedure only twice at most. In case the engine does not start, carry out a troubleshooting according to the section entitled "Problems, Causes, Remedy".

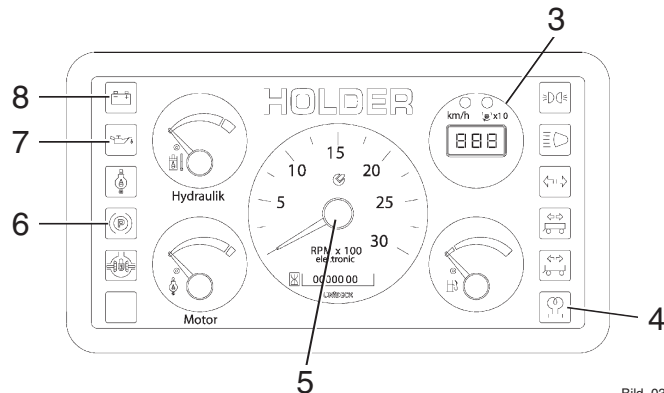

Bild\_033

### Taking into Service

- Release the ignition key as soon as the engine turns over. The battery charge indicator (8) and the engine oil pressure indicator (7) will go out.
- Set the engine speed with the hand throttle (1) or accelerator pedal to the desired RPM (5) .

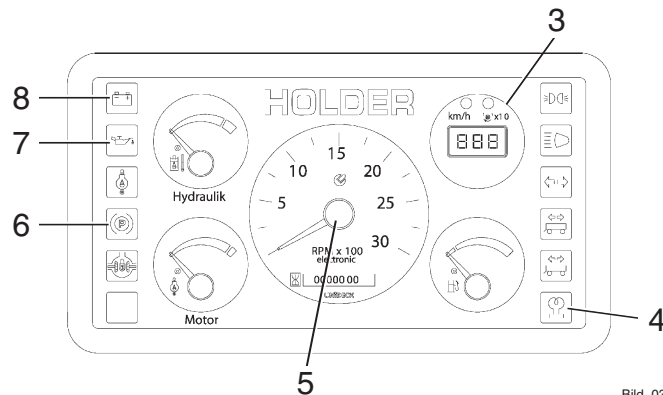

Bild\_033

### Checking the Brakes and Steering for Proper Operation

- Make a short trial run and check the steering and brakes for proper operation.



#### **DANGER**

*Do not drive a tractor with a defective steering and/or braking system.*

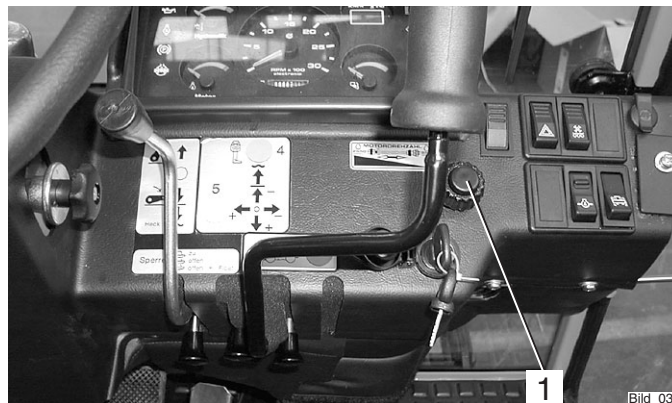

Bild\_032



## Operation

### Before Starting to Drive

When driving on public highways, observe the regulations of the highway code.



#### Driving Safety Rules

- Drive the tractor only from the driver's station with the cab doors closed.
- Always adjust your speed to the driving conditions and the load you are carrying.
- Never drive downhill without having the tractor in gear or with the engine stopped.
- Before driving, check that no-one is standing in the immediate vicinity of the vehicle.
- The driving behaviour of the tractor is strongly affected by the weight and swing range of the implements, trailers and, if fitted, ballasting. Therefore drive slowly with heavy equipment and take the longer braking distance into consideration.



#### **DANGER**

*Parts of implements posing a danger to traffic must be covered before driving or identified with warning signs.*

- Switch off the differential lock when travelling along a curve.
- When driving on slopes, drive downhill if possible; if you have to turn, turn only when driving uphill.
- On steep slopes you can improve traction by activating the differential lock.
- Drive across slopes only in accordance with the notes at the end of this chapter.

### Operation

#### Driving

##### Driving with Hydrostatic Drive and Digital Electronics

- Start the engine.
- Select the direction of travel with the forward/reverse selector lever (3) (forward left or reverse right).
- The direction arrow for forward (1) or reverse (2) travel comes on.



#### NOTE

After starting the engine, the forward/reverse selector lever must be operated once if it was in the forward or reverse position when starting. This prevents any accidental movement of the tractor when starting the engine.



#### NOTE

You can also select the new direction while travelling at reduced speed.

#### CAUTION

The tractor will brake strongly and accelerate in the opposite direction.



- Set the drive range pre-selection lever (4) (between the seats) to the desired driving range:



#### ATTENTION

This must only be done when the tractor is stationary.



Bild\_181

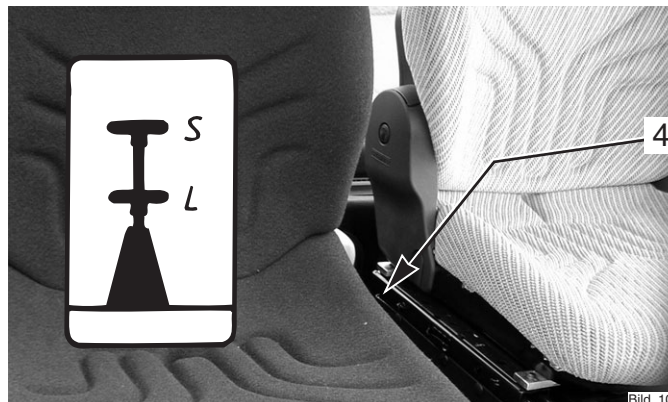

Bild\_108

## Table of Driving Ranges

Position	Symbol	Function	Travel Speed*	Use
Top position	S	Fast speed	0 - 30 / 36 km/h	Low tractive force, eg for highway driving
Centre position	0	Drive off		Towing
Bottom position	L	Slow speed	0 - 11.5 km/h	High tractive force, eg for working operation or pulling trailers on gradients

- Select the desired driving program at the driving program switch (6). The selected position is illuminated:

You can select 4 programs:

Stage 1 and 2 programs	eg road travel
Stage 3 and 4 programs	eg working operation

\* Depending upon the model



## Operation

Table of Driving Programs\*

Position	Symbol	Function	Use
Range 0	STOP	Drive off	
Range 1	Rabbit symbol	Maximum speed	eg for highway driving
Range 2	Turtle symbol	Maximum speed	eg for highway driving
Range 3	PTO symbol	Travel speed adjustable with fine adjustment knob, is controlled automatically in case of high power demand of implement	eg for mowing
Range 4	Snow blower symbol	Travel speed adjustable with fine adjustment knob, is controlled automatically in case of high power demand of implement	eg special setting for snow blower

\* The driving programs can be optimised for special operations by your Service, eg controlled constant driving speed

**Selecting Road Speed (Transport Speed)**

The tractor is stationary.

- Set the program switch (6) to range 1 or 2.

**NOTE**

*The driving range can also be switched while driving at reduced ground speed.*

- Disengage the parking brake.
- Depress the accelerator pedal for the desired ground speed.

The tractor starts driving and can be driven up to maximum ground speed of the selected range.

- You can read the engine speed (8) and ground speed (7) on the multi-function display.

**Setting the Working Speed of Programs 3 and 4****NOTE**

*With programs 3 and 4 you can select the ground speed independent of the PTO rpm.*

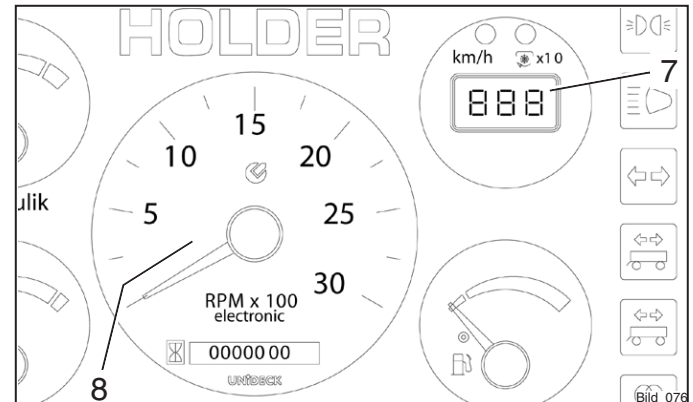

### Operation

The tractor is stationary.

- Set the inch knob (5) to 0.
- Set the program switch (6) to range 3 or 4.
- Adjust the PTO rpm with the hand throttle.



#### NOTE

The engine speed must reach at least 1500 rpm as the control is only effective beginning at this speed. You can read the speed on the multi-function display.



#### NOTE

You can also switch ranges while driving.

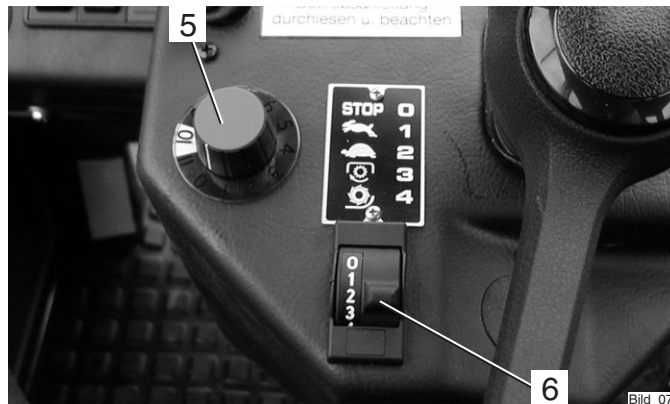

Bild\_075

The ranges 3 and 4 provide a speed as required by the load on the PTO.

This means that if, for example, the snow blower requires more power when meeting high resistance, the tractor drives more slowly. As the resistance decreases, the tractor accelerates again to the previously selected ground speed. Driving range 4 is especially adapted for particular applications.

- Set the PTO clutch lever (7) fast to the vertical position to engage the PTO.
- Disengage the parking brake.



Bild\_077

### Adjusting the Inch Knob

**NOTE**

While driving you can adjust the inch knob (5) at any time for fine and infinitely variable control of the ground speed.

- In position 0 the tractor is stationary. When turned further clockwise, the tractor starts driving and at the maximum scale position 11, the maximum ground speed of the driving range is achieved.
- You can read the engine speed and ground speed at the multi-function display.

**NOTE**

In this operating mode, the tractor drives automatically and needs only to be steered.

This mode is best for operating an implement as you can concentrate fully on controlling the implements.



### Operation

#### Operating the Inch Pedal

- 7 Inch pedal
- 8 Accelerator pedal

This function is active for all driving programs.



#### NOTE

*The inch pedal allows driving speed to be reduced temporarily.*

- Depress the inch pedal (7) to reduce driving speed and to stop completely.
- Release the inch pedal again behind the obstacle. The tractor will resume the previously selected driving speed.

#### Changing the Direction of Travel

- Preselect the new direction with the forward/reverse selector lever (9).
- The tractor will come to a standstill and accelerate again in the opposite direction.

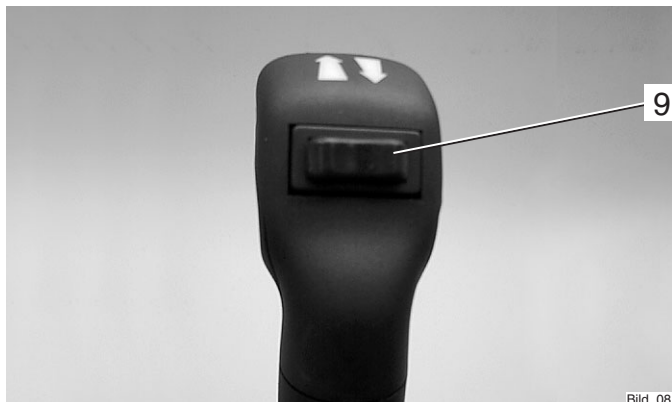
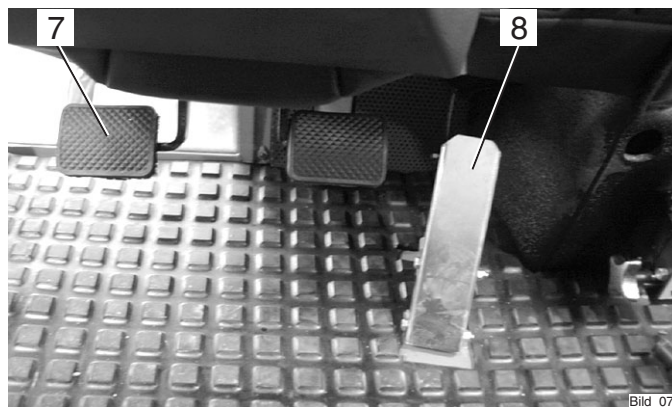



### Driving with Hydrostatic Drive, Digital Electronics and Dual Drive

- Set the drive range pre-selection lever (1) to "S".  
The DUAL Drive will work only in this driving range.

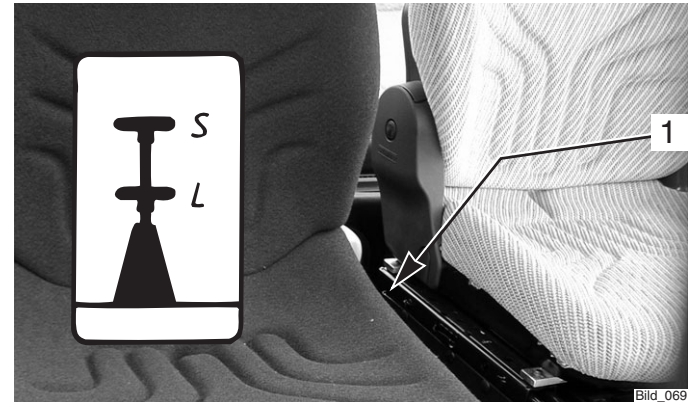

Table of Driving Ranges with Dual Drive

Position	Symbol	Function	Hydrostatic Speed*	DUAL Drive Speed*	Use
Top position	S	Fast range	0 - 30 / 36 km/h	0 - 30 / 42 km/h	Low tractive force, eg for road travel
Centre position	0	Drive off			For towing
Bottom position	L	Slow range	0 - 11.5 km/h/ 14.5 km/h	-	High tractive force, eg for working or pulling trailers on gradients

\* Depending on the version

### Operation

- Set the program switch (2) to driving range 2.



#### **ATTENTION**

*Drive the tractor warm for approx. 10-12 min. at driving range 2.*

- Set the program switch to driving range 1.



#### **NOTE**

*The functions of the drive are same except for the overdrive:*

*When the driving speed\* exceeds 25 km/h, the transmission automatically shifts from the hydrostatic drive to the mechanical gear.*

*If the driving speed drops again, the transmission shifts back to the hydrostatic drive.*



\* Depending on the version

### Driving with the Mechanical Gearbox

- Set the gearshift lever to the neutral position.
- Start the engine.
- Select the direction of travel with the forward/reverse selector lever (1) (forward or reverse). The indicator will flash green (forward or reverse).
- Fully depress the clutch pedal (2) (buzzer sounds until shifting is completed). The indicator is now illuminated green.
- Shift the gearshift lever (4) left (looking forward) into the desired gear.

4 gears 1-2-3-4 are available.

- Shift the range selector lever (5) right (looking forward) in the desired speed range.

4 speed ranges are available:

- S - Fast
- M - Medium
- L - Slow
- LL - Very slow

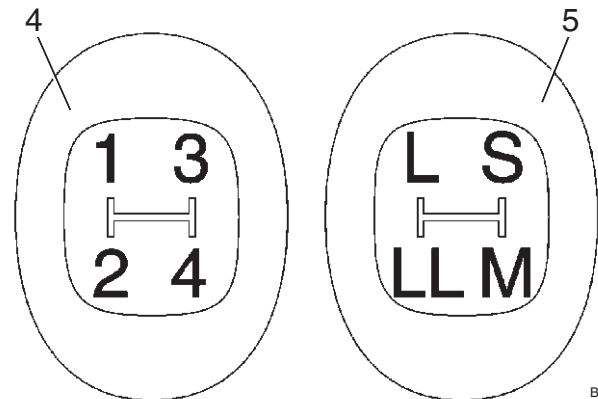
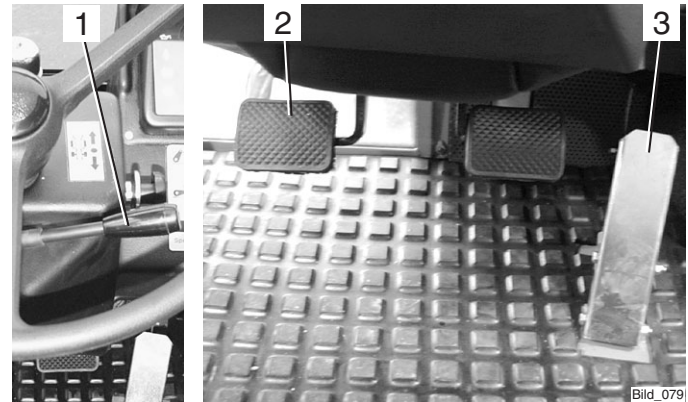

Bild\_082

## Operation



### NOTE

The label (4) shows the possible shift combinations. You have a total of 16 gears available, both for forward and for reverse travel.

- Release the clutch pedal (5) to start driving.



### ATTENTION

Do not keep the foot on the clutch pedal when driving.

- Control the driving speed with the accelerator pedal (6) or the hand throttle.



### NOTE

The attainable driving speeds can be read in the table in the technical data section.



### ATTENTION

When downshifting, the driving speed must be reduced and lie in the area of the low speed range. As the transmission is synchronized, you do not have to give gas when downshifting.

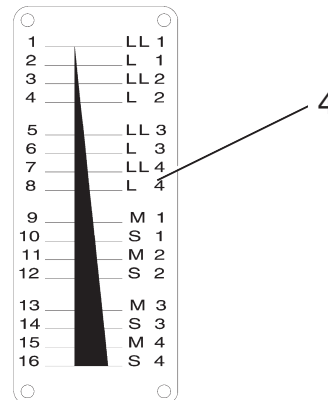

Bild\_083

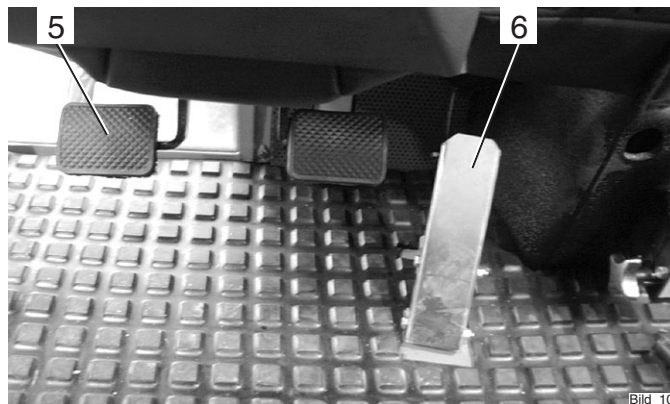

Bild\_109

**Changing the Direction of Travel****ATTENTION**

*The direction of travel can be changed when driving slowly.*

- To change the driving direction from forward to reverse, the forward/reverse selector lever (1) must be pulled back.
- The indicator (3) flashes green and shows the selected direction of travel.
- As soon as the clutch pedal is fully depressed, a buzzer sounds until shifting is completed. Then the indicator (3) is steadily illuminated green.
- Release the clutch pedal to drive in reverse.

**NOTE**

*When working, we recommend preselection of the direction of travel while driving.*

**ATTENTION**

*If the clutch pedal is released before the shifting is completed, the mechanical gear shifts into neutral (0). Both arrows are flashing (2 and 3).*

- Depress the clutch pedal again.  
The green indicator is on steadily, shifting is completed.



Bild 182

## Operation

### Engaging the Differential Lock



#### NOTE

With the differential lock you can improve traction on soft, slippery ground. The lock is engaged when the engine speed is over 1000 rpm. You can keep the differential lock engaged steadily and also only briefly by toggling the switch momentarily.



#### ATTENTION

The differential lock may only be used when driving straight.

- Toggle the differential lock switch (1) down and hold it. The indicator (2) in the multi-function display comes on red. An intermittent alert sounds at the same time. The differentials of both axles are locked and power is transferred to all 4 wheels equally.
- Toggle the differential lock switch (1) up. The switch remains on until you return it to the middle position again.

### Disengaging the Differential Lock

- Return the differential lock switch (1) to the middle position. The differentials are in operation again. The indicator (2) goes out and the alert in the multi-function display ceases.

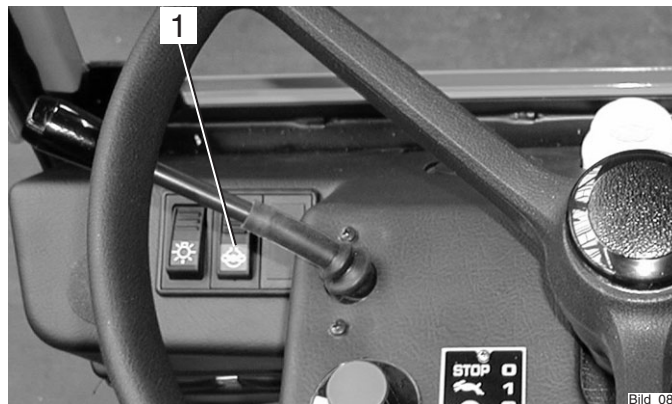

Bild\_085

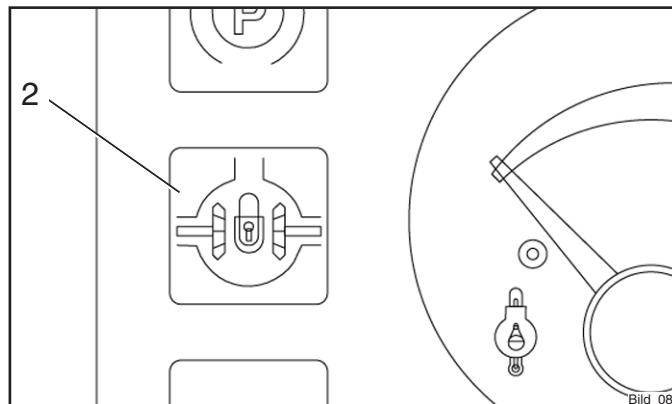

Bild\_084

## Steering

The articulated steering is operated hydraulically. The wheels also stay in track in curves, so that implements are guided without any lateral offset.

### Steering

- Turn the steering wheel (1) in the desired direction.

The possible turning radii depend on the tires and track widths of your tractor. For exact information refer to the track width table in the section "Technical Data".

## Braking

The service brake is a wet disc brake mounted in the front axle. It is operated hydraulically and acts on all four wheels. The parking brake is mechanical and operated with the parking brake lever.

### Operating the Service Brake



#### **ATTENTION**

*The engine can stall if you brake too hard in the mechanical gear.*

- Depress the brake pedal (2).



#### **NOTE**

*If the mechanical gearbox is fitted, the clutch pedal must also be operated.*

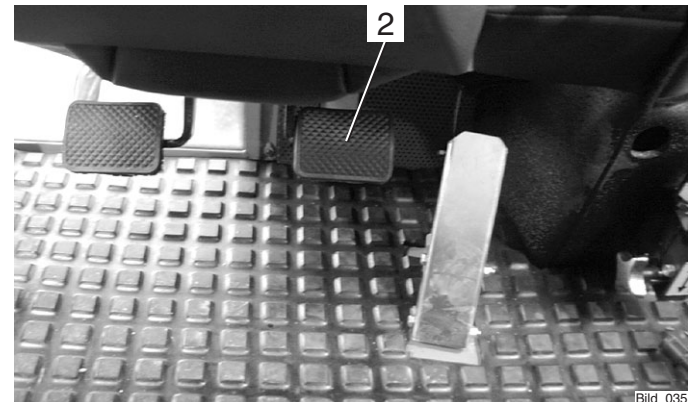
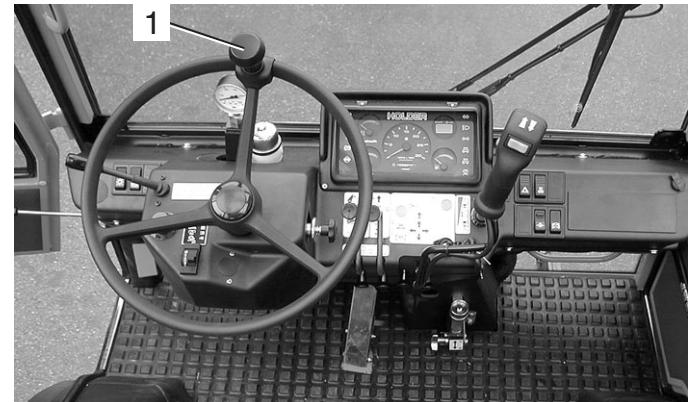

Bild\_035

### Operation

#### Engaging the Parking Brake



#### ATTENTION

*The parking brake is not intended to be used for braking while driving.*

- Pull the parking brake lever (2) up. The parking brake is engaged, the parking brake indicator (3) in the multi-function display comes on red.

#### Disengaging the Parking Brake

- Pull on the parking brake lever (2) slightly. While depressing the release button (1) in the lever, push the lever downwards. The parking brake is disengaged, the parking brake indicator goes out.



#### ATTENTION

*An alert is sounded when driving with the parking brake applied.*

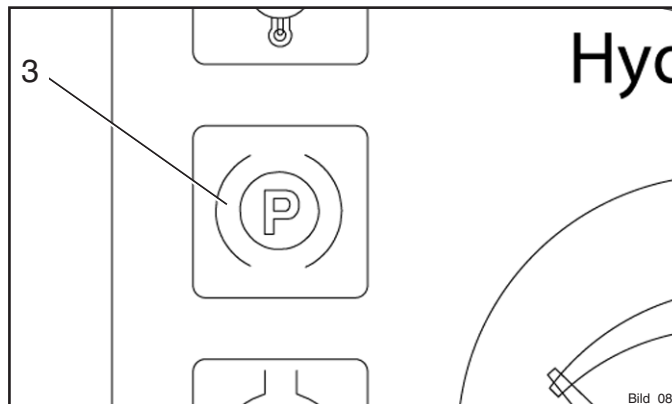
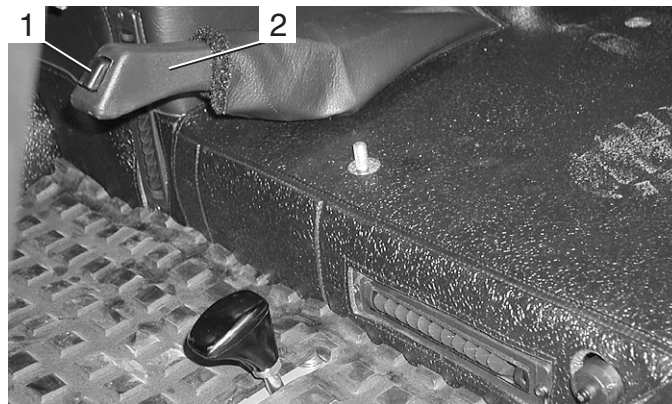



**Operation****Driving on Slopes****DANGER**

*Driving on slopes is dangerous as the tractor can tip over if the centre of gravity exceeds the tip-over limit on an extreme slope.*

The following factors reduce the hazard:

- small or no load
- low ground speed
- low gradient
- low tire inflation pressure

**NOTE**

*The driving comfort and the traction of the tractor can be improved by reducing the inflation pressure.*

- large track width
- level, non-bumpy terrain

When turning on slopes we recommend the proceeding as shown in the drawing on the right.

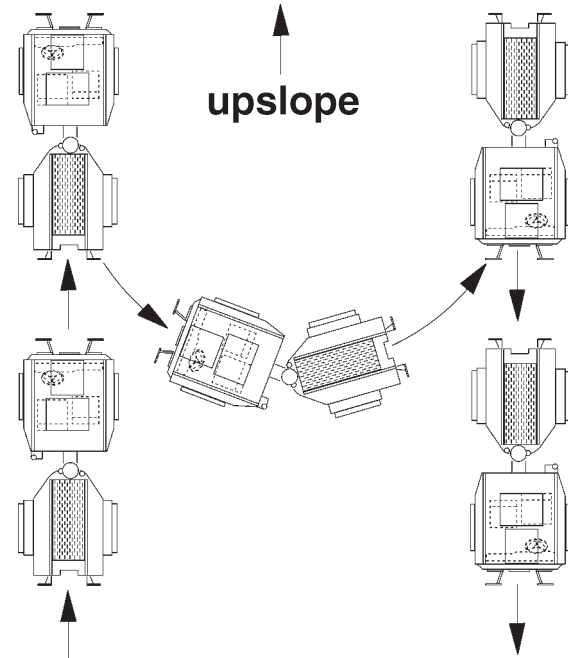



## Special Operating Instructions

### Stationary Operation

The tractor can be used for stationary operation, for example, to drive a water pump via the PTO shaft.

**ATTENTION**

*Place the tractor on level ground in both directions.*

- Attach the stationary equipment to the PTO shaft (1).
- Set the gearshift lever (with a mechanical gearbox the gearshift and range selector lever) to the zero position.
- With a hydrostatic drive, set the program switch to 0.
- Apply the parking brake.

**DANGER**

*Before switching on the PTO, make sure no one is standing in the vicinity of the tractor and the rotating PTO shaft.*

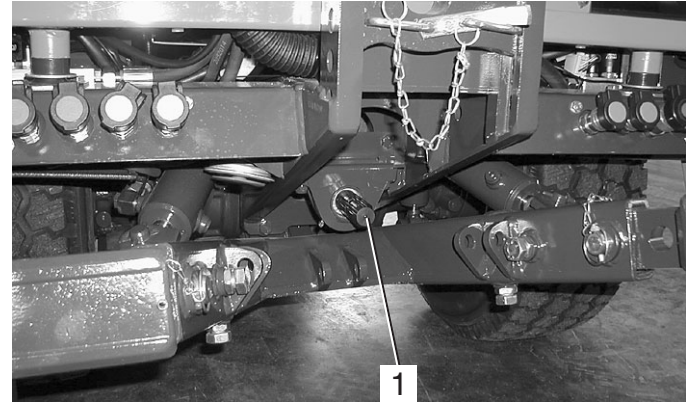

### Hydraulic Oil Flow for Stationary Operation

When the tractor is stationary, hydraulic oil is available, for example, for the operation of a hydraulic pump.

**Max. oil quantity available ..... 22 litres (5.8 USGAL.)**

**ATTENTION**

*Before starting to drive after stationary operation, first check the hydrostatic steering. Turn the steering wheel fully to the right and left several times to release air from the steering system.*

## Special Operating Instructions

### Adjusting the Track Width

You can widen the track width of the tractor by adding spacers. You have a choice of 3 different spacers.



#### **DANGER**

*Observe the safety notes on safe parking and jacking up for the wheel change in the maintenance manual.*

- Remove the wheels. Turn the wheels inside out or install the selected spacers.



#### **ATTENTION**

*The same spacers must be installed on all four wheels.*



#### **NOTE**

*The arrows on the tires must show in the forward direction of rotation.*

- Tighten the wheel nuts to the specified torque.

**Torque to ..... 340 Nm**

**Special Operating Instructions****Operating the Emergency Start (Hydrostatic Drive with Dual-Drive Only)****NOTE**

*In case the engine was stalled and can not be started again, the emergency start must be operated before a renewed starting attempt.*

- Fully depress the inch pedal.
- Briefly operate the starter.
- Pull the handle for the emergency start (1) up.
- Start the engine again.

**Operating the Emergency Shift (Mechanical Gearbox Only)****NOTE**

*In the event of a failure of the electrical installation, it is possible to drive to an authorized workshop with the emergency shift.*

- Turn off the engine.
- Apply the parking brake
- Put the range selector lever and the gearshift lever in neutral
- Remove the wire safety (3).
- Carefully press the ball socket of the servo motor (2) down until it is disconnected.
- Move the operating lever (1) to the desired position. V = forwards or R = reverse.
- Start the engine and drive to the workshop.

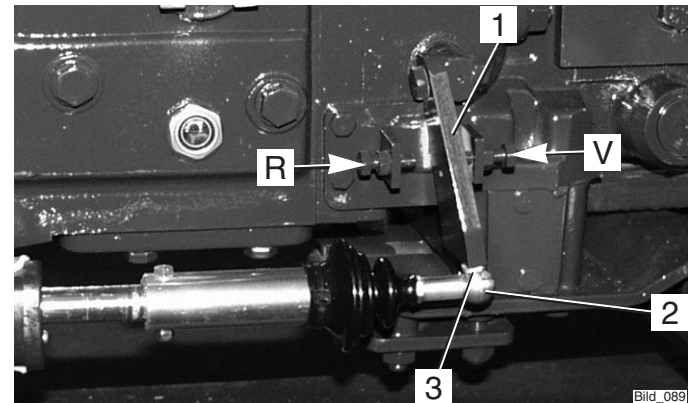

Bild\_099

## Special Operating Instructions

### Operation in Winter

#### Preheating of Oil\*

Before starting the engine at temperatures below - 20 °C, turn on the heating element\* for preheating the oil.

- Connect the preheating system plug to a 230 VAC (U.S.: 120 V) source.

Follow the Operating Instructions of the manufacturer.

#### Winter Diesel Fuel

Whenever temperatures fall below 0 °C, use winter diesel or super diesel fuel or additives recommended in the maintenance manual.

#### Engine Oil for Winter Operation

Fill engine oil with a suitable SAE class as recommended the maintenance manual.

The cold start capability of the engine can be reduced if the temperature limits are underrun occasionally, but this does will not damage the engine.

#### Hydraulic System

The hydraulic functions are sluggish and slower during cold temperatures. Bring the hydraulic system to operating temperature by operating it without a load.

\* Option

### Putting on Snow Chains

Snow chains can be mounted on the tires to improve grip. In the following table you will find the order numbers for RUD chains which fit on the listed tires. You can also fit snow chains from other manufacturers if these have the proper dimensions.

<b>Tires</b>	<b>Snow chain type (RUD Order No.)</b>
10.5-18 MPT	24 553 and 22 553
400/60-15.5	22 177
33x12.50 R 15/33x12.5-15	22 167
33x15.50-15	22 174
31x15.50-15 Terra	22 548
36x13.5-15	24 178

### Ballast Weights

The weight of the machine can be increased with ballast weights. The ballast weights must be applied parallel with the same weight on each axle and side.

## Operating the Implements

We have tested and approved a large number of possible implements for use with this tractor. We recommend contacting our customer service before installing special equipment.

### Possible Implements

Rotary mower with different widths  
Reel mower  
Flail-type mower  
Hedge cutters  
Leaf blower and grass collector  
Weed brushes and -burners  
Weed killers  
Casting fixtures  
Distributors for service in winter  
Conveyor feed distributors for different distribution widths  
Snow blowers  
Snow plow  
Sweepers  
Spray and high-pressure cleaners  
Oil removal device

### Safety Instructions for Handling Implements

Before the installation of implements, the tractor must be parked safely.

It must be secured against rolling, for example, with the parking brake or, if required, with chocks.



#### **DANGER**

*Be careful to avoid injury from being crushed or cut when implements are being attached.*



#### **DANGER**

*No-one must come between the tractor and implement unless the tractor is secured against rolling.*

*For highway driving purposes, the implements must be lifted and secured against lowering. Observe the applicable safety regulations for your implement. Observe the Operating Instructions and the safety rules for your implement.*



#### **DANGER**

*During work breaks, the implement must always be lowered to the ground in order to relieve the hydraulic cylinders. Accidents can occur if the lowering is uncontrolled, for example, due to damage or accidental movement of the control levers.*



#### **DANGER**

*Any parts of the implements posing a traffic hazard must be covered before driving or identified with warning signs.*

## Operating the Implements

### Additional Information for Implements



When installing attachments on the front and rear 3-point lift, do not exceed the permissible total weight, the permissible axle loads and tire carrying capacities of the tractor. The front axle of the tractor must always be loaded with at least 20 % of the tractor's empty weight.

Before the purchase of equipment, make sure these conditions are met by performing the following calculations or by weighing the tractor-equipment combinations.

### Determining the Total Weight, Axle Loads and Tire Carrying Capacity including the Minimum Ballasting

For the calculation you need the following data:

$T_L$ (kg)	Empty weight of the tractor <sup>1)</sup>
$T_V$ (kg)	Front axle load of the empty tractor <sup>1)</sup>
$T_H$ (kg)	Rear axle load of the empty tractor <sup>1)</sup>
$G_H$ (kg)	Total weight rear implement/rear ballast <sup>2)</sup>
$G_V$ (kg)	Total weight Front implement/front ballast <sup>2)</sup>

- a (m) Distance between centre of gravity of front implement/front ballast and centre of front axle <sup>2) 3)</sup>
- b (m) Tractor wheelbase <sup>1) 3)</sup>
- c (m) Distance between centre of rear axle and centre of lower link ball <sup>1) 3)</sup>
- d (m) Distance between centre lower link ball and centre of gravity of rear implement/rear ballast <sup>2)</sup>

- 1) See operating manual, Technical Data
- 2) See price list and/or operating manual of the implement
- 3) Measure

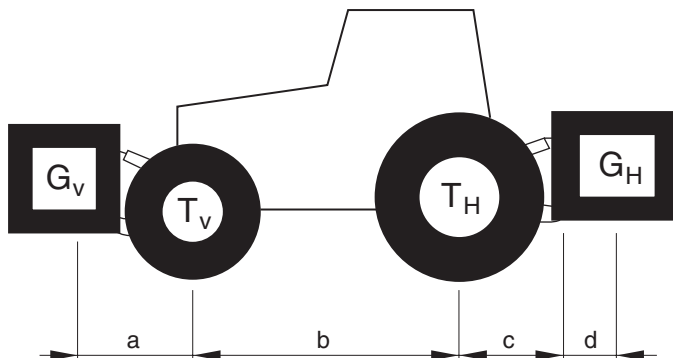



**Operating the Implements****Rear Implement or Front/Rear Combinations**

1) Calculation of the minimum front ballasting  $G_{V \min}$

$$G_{V \min} = \frac{G_H \cdot (c+d) - T_V \cdot b + 0.2 \cdot T_L \cdot b}{a+b}$$

Enter the calculated minimum ballasting required for the front of the tractor in the table.

**Front Implement**

2) Calculation of the minimum rear ballasting  $G_{H \min}$

$$G_{H \min} = \frac{G_V \cdot a - T_H \cdot b + X \cdot T_L \cdot b}{b+c+d}$$

the calculated minimum ballasting required for the rear of the tractor in the table.

(Value X is 0.25 for Holder tractor 4-wheel)

3) Calculation of the actual front axle load  $T_{V \text{tat}}$

(If the minimum front ballasting ( $G_{V \min}$ ) is not obtained with the front implement, the weight of the front implement must be increased to the weight of the minimum front ballasting.)

$$T_{V \text{tat}} = \frac{G_V \cdot (a+b) + T_V \cdot b - G_H \cdot (c+d)}{b}$$

Enter the calculated actual and the permissible front axle load specified in the operating manual of the tractor in the table.

4) Calculation of the actual total weight  $G_{\text{tat}}$

(If the required minimum rear ballasting ( $G_{H \min}$ ) is not obtained with the rear implement ( $G_H$ ), the weight of the rear implement must be increased to the weight of the minimum rear ballasting.)

$$G_{\text{tat}} = G_V + T_L + G_H$$

Enter the calculated actual and the permissible total weight specified in the operating manual of the tractor in the table.

5) Calculation of the actual rear axle load  $T_{H \text{tat}}$

$$T_{H \text{tat}} = G_{\text{tat}} - T_{V \text{tat}}$$

Enter the calculated actual and the permissible rear axle load specified in the tractor operating manual in the table.

## Operating the Implements

### 6) Tire carrying capacity

Enter the double value (two tires) of the permissible tire carrying capacity (eg see tire manufacturer documentation) in the table.

	Actual Calculated Weight		Specified Permissible Weight acc. to operating instructions		Double Permissible Tire Load Capacity (Two Tires)
Minimum ballast at front/rear	<input type="text" value=" / kg"/>		-		-
Total weight	<input type="text" value=" kg"/>	≤	<input type="text" value=" kg"/>		-
Front axle	<input type="text" value=" kg"/>	≤	<input type="text" value=" kg"/>	≤	<input type="text" value=" kg"/>
Rear axle	<input type="text" value=" kg"/>	≤	<input type="text" value=" kg"/>	≤	<input type="text" value=" kg"/>

**The minimum ballasting must be mounted on the tractor either as attachment or ballast weight!**

**The calculated weights must be lower/higher (≤) than the permissible weights!**

## Operating the Implements

### Attaching Implements

The various implements are attached to the front lift or rear lift\*.

There are 2 different fastening categories:

Category I Pin diameter 22 mm

Category II Pin diameter 28 mm

The tractor can be adjusted to both categories by adjusting the catch hook bars and providing the catch hooks with or without reducer sleeves.



### **DANGER**

*Use only the following specified devices for attaching your implement.*

*Secure the implement against shifting or rolling off.*

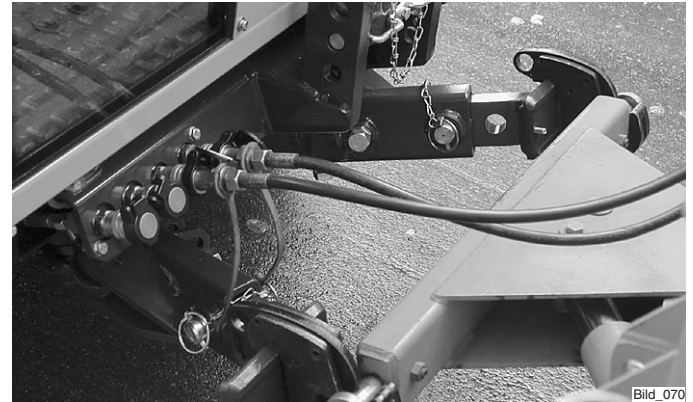

\* Option

### Operating the Implements

#### Adjusting Catch Hook and Catch Hook Bar

You can adjust the catch hook laterally and longitudinally.

- Measure the stand-off of the pins on your implement.
- Disengage the clamping screws (6) on both sides.
- Slide the catch hook laterally until the required distance is reached.
- Retighten the clamping screws.
- Equipment of category II can be attached with the catch hook (5) directly;
- For equipment of category I install the reducing sleeves on the left and right.

#### Adjusting the Length of the Catch Hook Bar

- Disengage 2 locknuts and clamping screws (inside and at bottom) on the lower link (2).
- Pull the linch pin out of the pin (1) and remove the pin.
- You can put the catch hook bar (3) in one of 3 positions.
- Insert the pin (1) in the hole and secure with the linch pin.
- Retighten the locknuts and clamping screws.



#### **DANGER**

*Make sure no-one is standing between the tractor and implement.*

- Drive the tractor to the implement to be picked up.

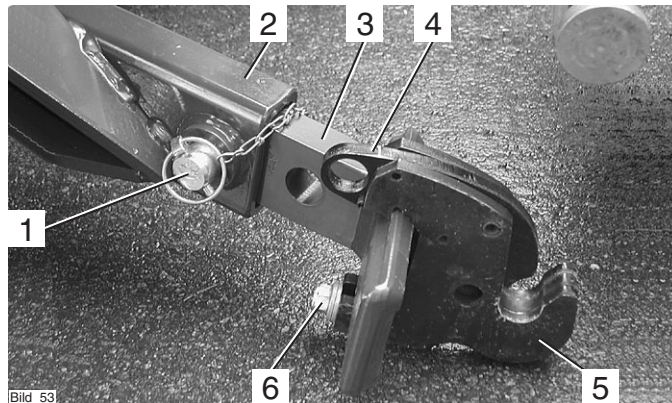

- |                      |  |
|----------------------|--|
| 1 Pin with linch pin | 4 Quick attach                                 |
| 2 Lower link support | 5 Catch hook                                   |
| 3 Catch hook bar     | 6 Clamping screw (adjustable) with 3 positions |

Hole	Position	Used for
1st hole	Front	Category I and II
2nd hole	Centre	Category I
3rd hole	Rear	Optional attachments

- Steer the catch hooks (5) below the attaching pin of the implement.
- Raise the front lift until the quick attach (4) closes and engages.

**Operating the Implements****Adjusting the Upper Link Mount**

The height of the upper link mount can be adjusted. The required height depends on your implement.

- 1 Upper link support
  - 2 Retaining spring
  - 3 Top link pin
  - 4 Height adjustment lever
  - 5 Upper link mount
- Raise the height adjustment lever (4).
  - Slide the upper link mount (5) to one of the 4 possible positions.
  - Release the height adjustment lever; the upper link support engages.
  - Pull the retaining spring (2) off the pin (3) and pull the pin to the side.
  - Adjust the upper link (8) to the proper length (screw in or out by rotating the sleeve); secure the upper link with the locking lever (7).
  - Insert the pin through eyelet on the upper link and secure the pin again with the retaining spring.

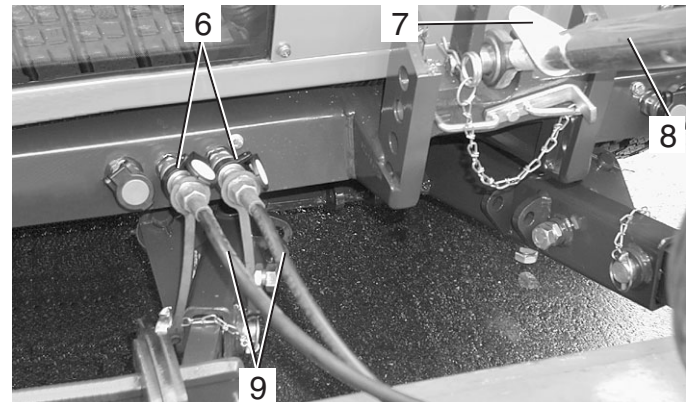
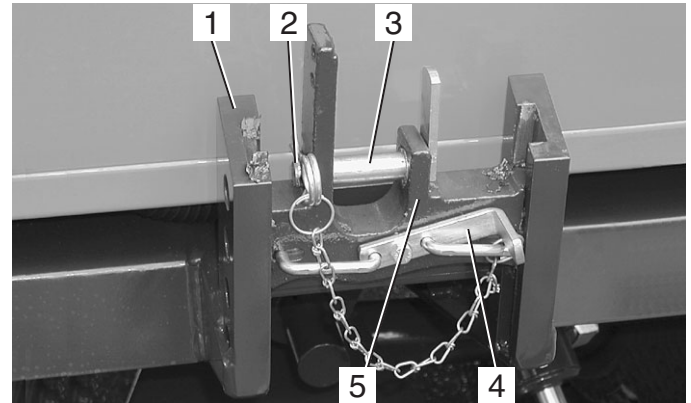

## Operating the Implements

### Coupling Hydraulic Lines



#### ATTENTION

The hydraulic couplings on the tractor must be without hydraulic pressure before the connection. The couplings on the tractor and the hydraulic hoses must be clean.



#### NOTE

Each implement has different functions and hydraulic lines for its control. Observe the operating manual supplied with your implement and make yourself familiar with the functions and colour codes.

- Open the protective caps of the hydraulic couplings (6).
- Attach the colour coded hydraulic hoses (9) of the implement to the hydraulic couplings of the same colour on the tractor.



#### ATTENTION

The hydraulic male couplings fit on each coupling and can therefore be connected incorrectly.

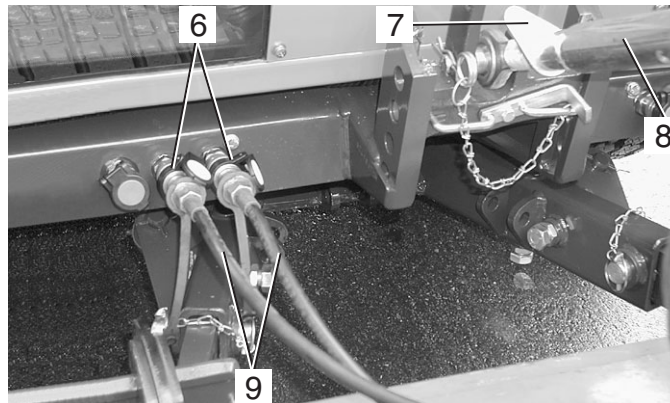

With the connection you therefore decide which function/movement of the implement is actually to be performed with the control lever assigned to the coupling.



#### DANGER

If you are not sure about the functions, determine them with trials at a safe place.

**Operating the Implements****Installing the Cardan Shafts**

Only use the shafts suited and intended for the implement. The shafts are supplied with the implement. The length of the articulated shaft must be adjusted before the first installation. In case of doubt, please contact our customer service. Observe installation instructions for the articulated shaft when installing it.

**DANGER**

*Turn off the engine before the installation. After the installation, fit the protective devices as specified. After the removal, cover the PTO shaft (1) with the protective cap again.*

**Removing Implements**

- Drive the implement to its storage place and lower it with the front lift.
- Stop the engine, but do not turn off the ignition.
- Operate all control levers for the front lift several times in all directions. This relieves the pressure in the hydraulic system.
- Slide the outer ring of the hydraulic couplings (1) back and disconnect the hydraulic hoses (2).
- Close the protective caps of the hydraulic couplings (as for item 4).
- Remove the upper link from the pin of the upper link support.
- Pull the quick attaches (3) up to release the implement pins.
- Lower the front lift and back off.

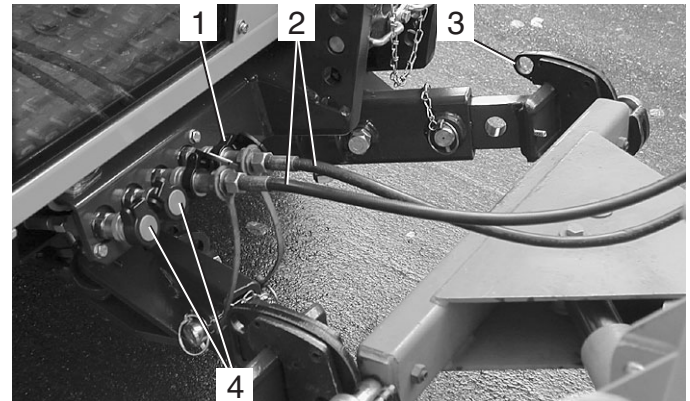
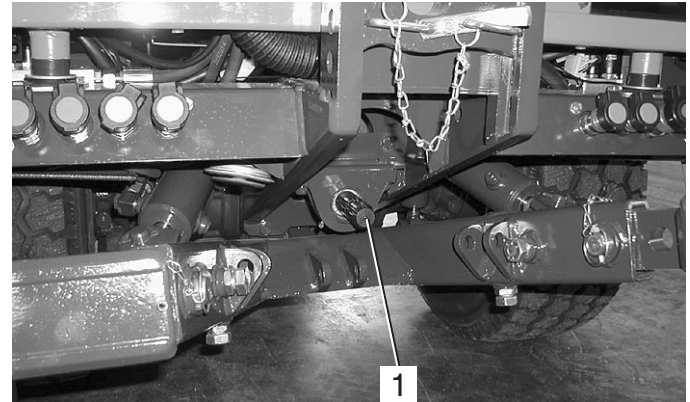

## Operating the Implements

### Operating Implements

#### Operating the Hydraulic Control Levers

- 1 Control lever for dump or rear lift\*
- 2 Control lever functions plate
- 3 Multi-function lever functions plate
- 4 Multi-function lever\*  
(front lift and driving direction)
- 5 Lock knob for longitudinal motion  
of the multi-function lever
- 6 Lock knob for laterally movement  
of the multi-function lever
- 7 Lock knob for longitudinal motion  
of the control lever
- 8 Lock knob functions plate

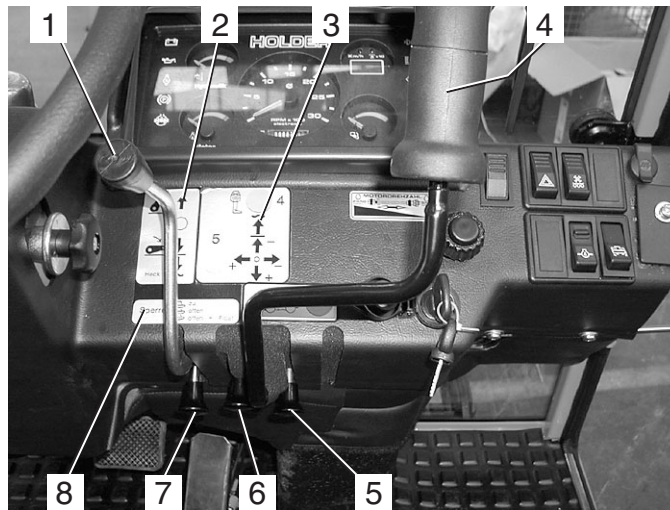

#### **NOTE**

The control levers control those functions of the implements which are connected to the front or rear hydraulic couplings. The couplings and notice plated for the control levers are colour coded, ie the colours match to the function.

\* Option



## Operating the Implements

**DANGER**

*Due to the variety of implements and connections, however, we recommend a trial run of the movement at a safe place without danger to persons or risk of material damage before starting operation.*

Two types of control levers can be installed: control levers (1) and multi-function levers (4).

### Control Lever Functions

You can recognize the functions on the notice plate (2).



**NOTE:** *At the base of the control lever (1) is a lock knob (7) with which the motions of the lever can be locked or released.*

The following movements are possible:

- Set the lock knob (7) to the middle position (lever free to move).
- Push the control lever (1) forward:
  - The implement is lifted.

You can stop the movement by releasing the lever.

- To lower the implement, pull the control lever (1) back:
  - The implement is lowered.
- Pull the control lever (1) fully back:
  - The float position of the implement is turned on, i.e. the implement can be moved with external use of force. The function is on until the control lever is disengaged again. It always returns to the neutral position.

### Functions of Lock-out Knob

With the lock knob (7) lever movements can be controlled as follows:

The functions are shown on the plate (8).

- Knob depressed - lever movement locked
- Knob in middle - lever movement released
- Knob pulled out - float position released

**NOTE:**

*If the lever movement is locked, you can prevent any unintended movement of the implement.*

*Transport lock for road travel.*

### Operating the Implements

#### Multi-function Lever Functions



#### NOTE

*Different versions of the multi-function lever can be installed.*

#### Multi-function Lever (Variant 1)

Multi-function lever (4) (without forward/reverse selector switch)

The multi-function lever can be operated forward and back as well as to the right and left: The functions are shown on the plate (3).

The following movements are possible:

- Fully pull out the lock knobs (5 and 6) (lever movement).
- Push the multi-function lever (4) forward:
  - The implement is lowered.

You can stop the motion by releasing the lever.

- For lifting, pull the multi-function lever (4) back:
  - The implement is lifted.

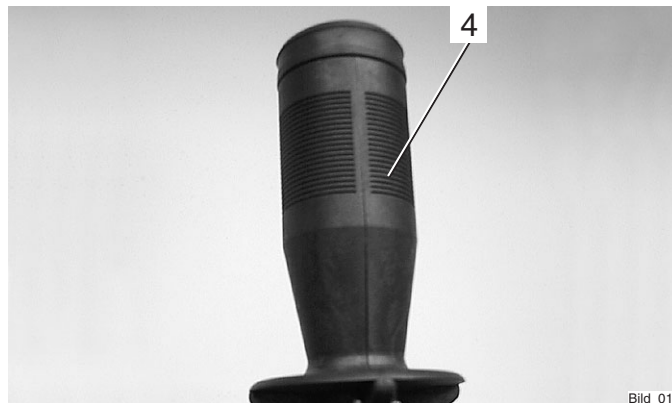

Bild\_018

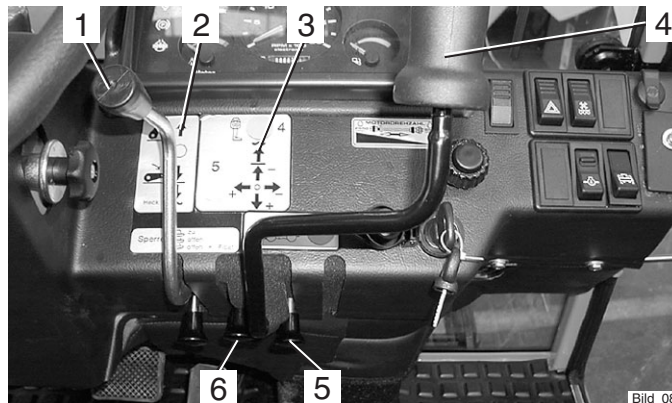

Bild\_088

## Operating the Implements

- Push the multi-function lever (4) fully forward:
    - The float position of the implement is turned on, ie the implement can be moved with external use of force. The function is on until the multi-function lever is pressed out of the detent again. It always returns to the neutral position.
  - Push the multi-function lever (4) to the right:
    - The implement is swung to the right\*.
  - Push the multi-function lever (4) to the left:
    - The implement is swung to the left\*.
- \* For example, when a snow plough is attached.



### **NOTE**

*Lock knob (5) controls the longitudinal motion, lock knob (6) the lateral movement of the multi-function lever.  
There is no float position for the lateral movement of the multi-function lever.*

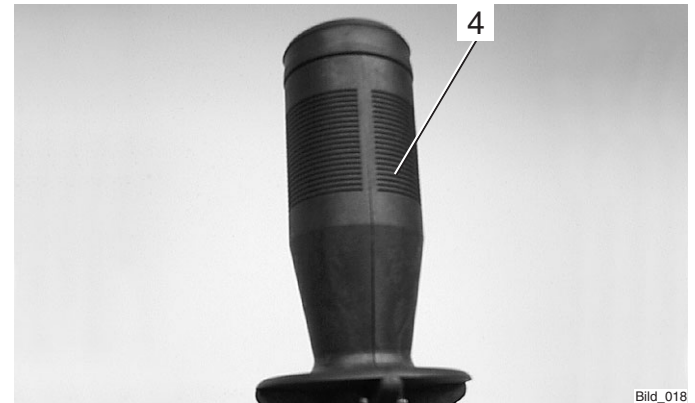

### Operating the Implements

#### Multi-function Lever (Variant 2)

- 1 Blue hydraulic couplings on
- 2 Blue hydraulic couplings off - float position
- 3 LED indicator, red or green
- 4 Functions off
- 5 LED indicator, red
- 6 Functions on
- 7 LED indicator, red
- 8 LED indicator, red or green
- 9 Yellow hydraulic couplings off
- 10 Green hydraulic couplings off - float position
- 11 Green hydraulic couplings on
- 12 Yellow hydraulic couplings on



#### **NOTE**

*With this multi-function lever it is possible to control 3 different functions:*

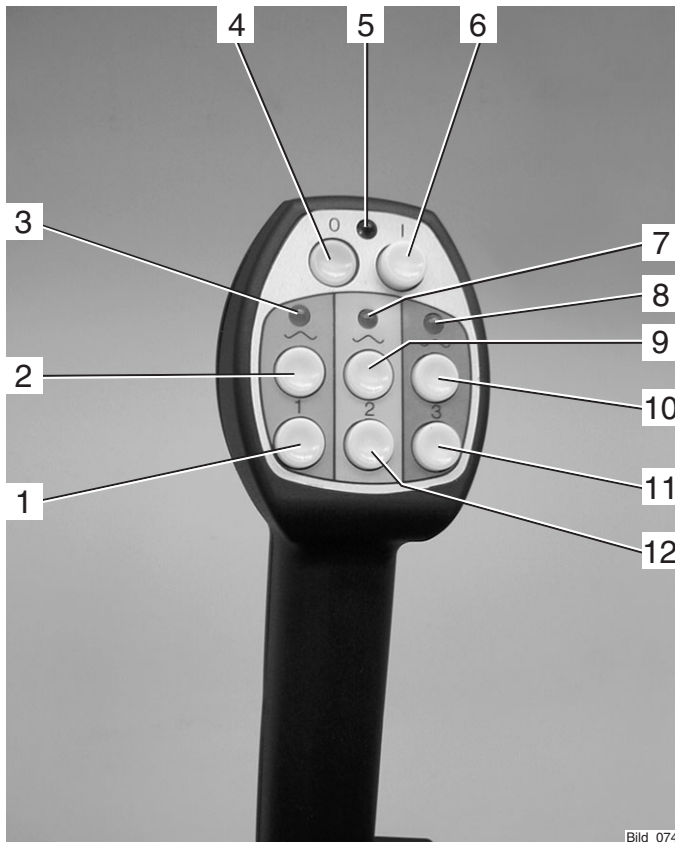

Bild\_074

Table of Multi-function Lever Functions (Variant 2)

Attachment	Motion	Related Hydraulic Couplings
Front lift 1	Lift - lower	Function at blue couplings
Front lift 2	Sideshifting left/right	Function at yellow couplings
Front lift 3	Tilting	Function at green couplings

The functions are selected as follows:

### Front Lift 1 - Lifting/Lowering

- Push button I (6). The red LED indicator (5) comes on.
- Press pushbutton 1 (1).



#### **NOTE**

*You can also operate the function only temporarily by pressing lightly.*

- The red LED indicator (3) comes on.
- Push the multi-function lever forward.
  - The front lift is lowered.
- Pull the multi-function lever back.
  - The front lift is lifted.



#### **NOTE**

*In addition you can also select the float position\*:*

- Press the pushbutton (2) blue hydraulic couplings off - float position.
- LED indicator (3) is illuminated green. To turn it off, press the pushbutton (1) lightly.
- LED indicator (3) goes off.
- To turn the function off, press pushbutton 0 (4). The red LED indicator (5) extinguishes.

\* Option

### Operating the Implements

#### Front Lift 2 - Shifting Left/Right

- Push button I (6). The red LED indicator (5) comes on.
- Press pushbutton 2 (12).



#### NOTE

*You can also select the function only temporarily by pressing lightly.*

- LED indicator (7) is illuminated red.
- Push the multi-function lever forward
  - to move the front lift to the left.
- Pull the multi-function lever back
  - to move the front lift to the right.

You can also select the float position:

- Push the multi-function lever fully forward.
- To deselect the float position, pull the lever back.  
To turn off, press pushbutton (9) lightly.
- The LED indicator (7) extinguishes.
- To deselect the function, press pushbutton 0 (4).  
The red LED indicator (5) extinguishes.

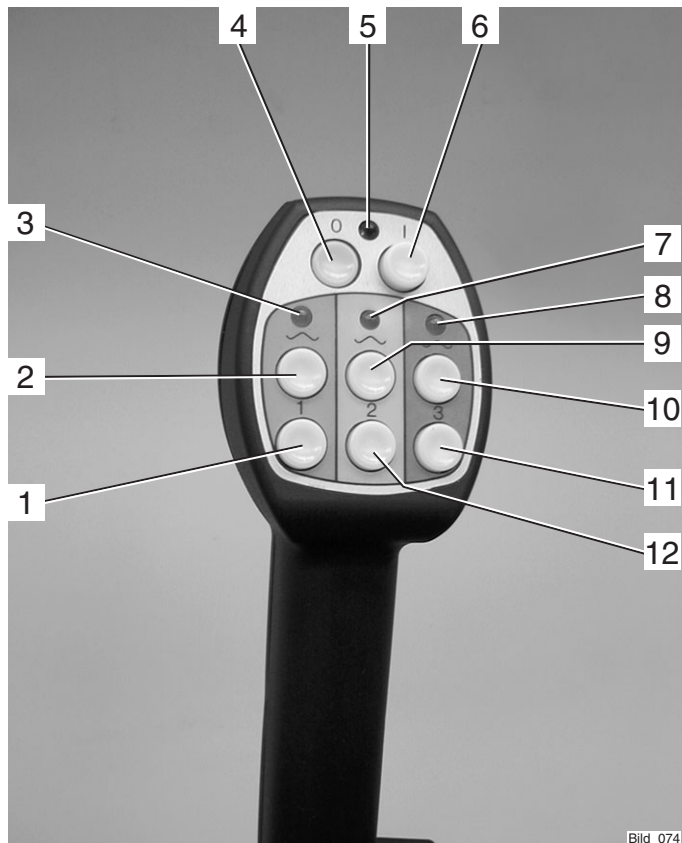

Bild\_074

## Operating the Implements

**Front Lift 3 - Lateral Tilt**

- Push button I (6). The red LED indicator (5) comes on.
- Press pushbutton 3 (11).

**NOTE**

*You can also select the function only temporarily by pressing the button lightly.*

- LED indicator (8) is illuminated red.
- Push the multi-function lever forward
  - The front lift is tilted to the left.
- Pull the multi-function lever back.
  - The front lift is tilted to the right.

In addition you can also select the float position\*:

- Push the pushbutton (10) green hydraulic couplings off - float position.
- LED indicator (8) is illuminated green.  
To turn it off, press the pushbutton (11) lightly.
- The LED indicator (8) extinguishes.
- To deselect the function, press pushbutton 0 (4). The red LED indicator (5) extinguishes.

\* Option

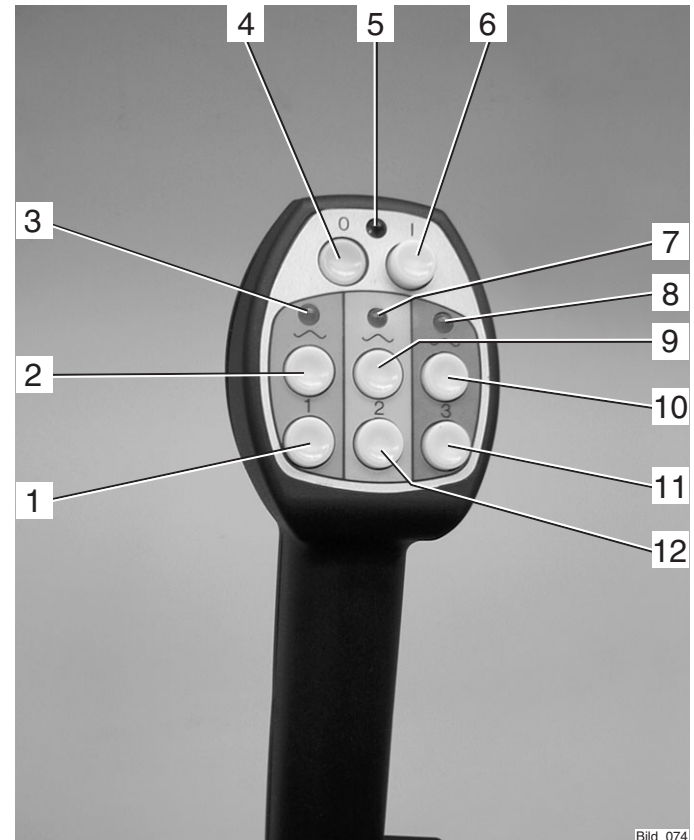

Bild\_074

### Operating the Implements

#### Multi-function Lever (Variant 4)

- 1 Forward direction arrow (illuminated if selected)
- 2 Reverse direction arrow (illuminated if selected)
- 3 Forward/reverse selector switch (left forward - right reverse)
- 4 Front lift float position pushbutton
- 5 Multi-function lever
- 6 Front lift pushbutton
- 7 Yellow pushbutton, left (front when looking forward) (movements at yellow hydraulic couplings activated)
- 8 Yellow pushbutton, right (front when looking forward) (movement at green hydraulic couplings activated)

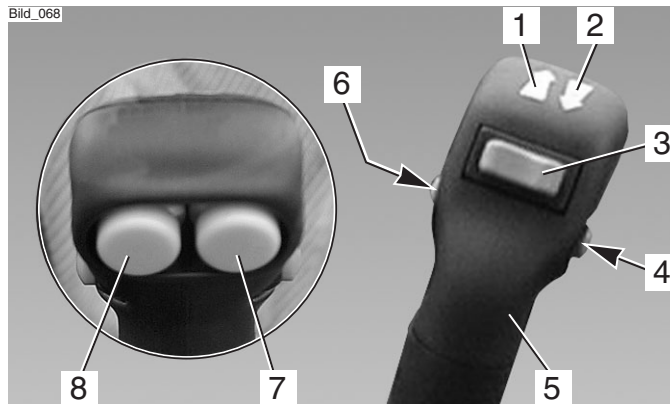

#### Activating Functions (Operation)

Press the desired pushbutton and move the multi-function lever either forward/back or across, depending upon the required function.



## Operating the Implements

## Operating the PTO

**DANGER**

The PTO clutch lever (3) must be turned off.  
To turn it off, it must be put in the horizontal position.

- Start the engine.
- Select the required PTO rpm with the PTO selector lever (2).
- To do so, pull the lever to the front and operate it upwards or downwards.

The possible positions are shown on the plate (1).

- Up position - 540 rpm
- Middle position - OFF
- Down position - 1000 rpm

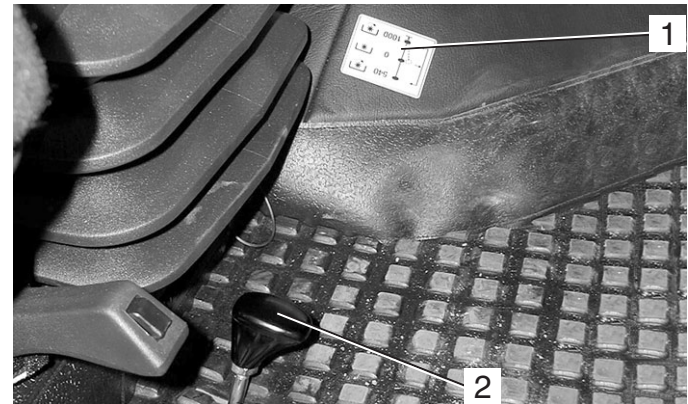

Bild\_087

### Operating the Implements

#### Engaging the Front PTO



#### **ATTENTION**

*Never engage the PTO with the engine off.*



#### **DANGER**

*Before engaging the PTO, make sure no-one is standing close enough to the tractor and the driven implement to be hurt.*

- Pull the PTO clutch lever (3) quickly to the vertical position. The pressure point must be passed very noticeably. The front PTO is turned on.
- To disengage it, return the PTO clutch lever to the horizontal position.
- Return lever (2) to position 0 (neutral).



#### **DANGER**

*After being disengaged, the installed equipment can continue to run. Wait until the equipment is stationary before working on it again.*

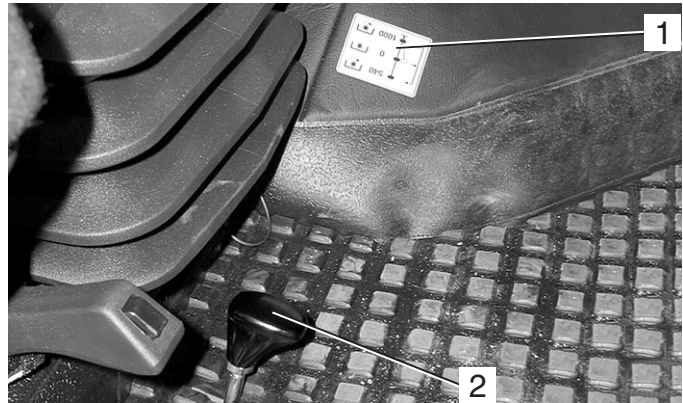

## Operating the Implements

## Engaging the Rear PTO

**NOTE**

The rear PTO can be engaged with PTO selector lever (4) located at the articulated joint. The lever positions are shown on the plate (5).

- PTO selector lever (3) must be turned off.
- Move PTO selector lever (4) up to engage the rear PTO.

**DANGER**

Before engaging the PTO, make sure no-one is standing close enough to the tractor and the driven implement to be hurt.

- Pull the PTO clutch lever (3) up quickly to the vertical position. The rear PTO is engaged.
- To disengage it, return the PTO clutch lever to the horizontal position.
- Push the PTO selector lever (4) down again.

**DANGER**

After the equipment is turned off, it can still continue to run. Wait until the equipment is stationary before working on it again.

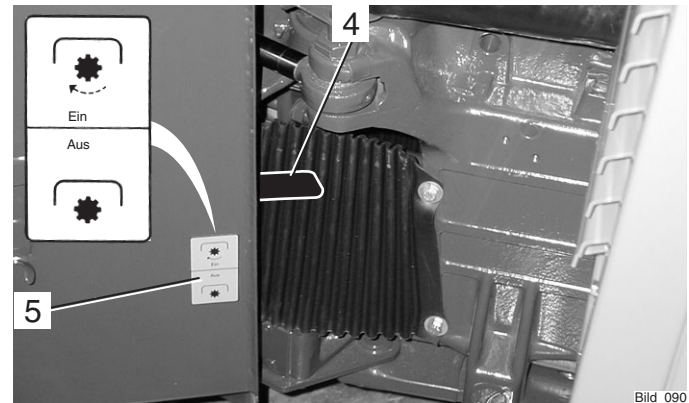

Bild\_090



Bild\_087

## Operating the Implements

### Operating the Hydraulic Carrier\* (Power Lifter)

- 1 Pressure adjuster
- 2 ON-OFF plate
- 3 Star knob for turning on/off

The hydraulic carrier allows for a weight compensation between implement and tractor. This increases the axle load and the climbing ability is improved. During road travel with a lifted implement, the hydraulic system absorbs shocks due to bumps in the road.

- Turn the star knob (3) to the left (ON position).
- Screw in the pressure adjuster (1) as far as possible.
- Raise the implement with the front lift.
- Read the pressure at the pressure gauge (4) at the driver's station (eg 100 bar) and select the float position.
- Screw out the pressure adjuster (1) until the pressure gauge indicates, for example, 50 bar (implement resting on ground). The selected pressure corresponds to the carried weight.
- Lower and raise the implement with the front lift.

\* Option

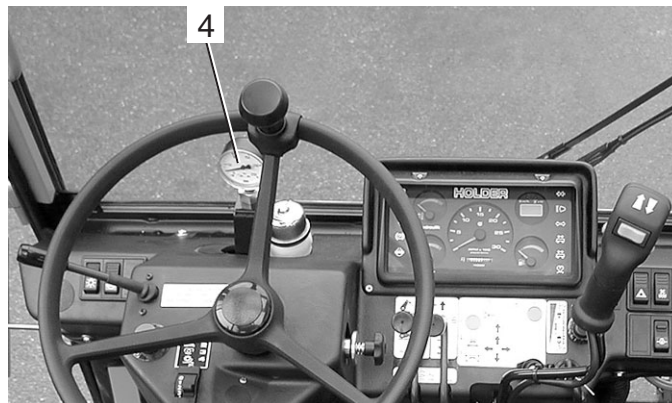
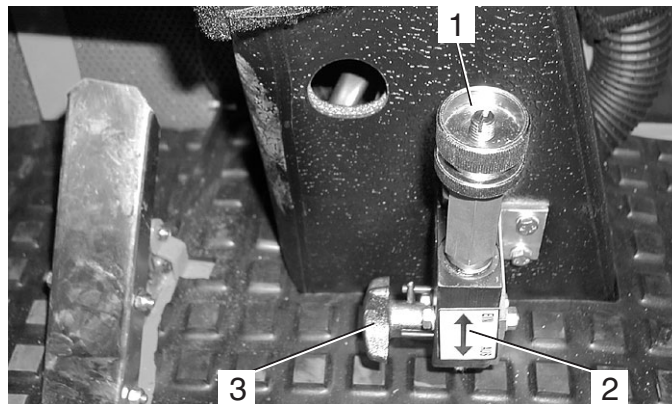

## Operating the Implements

## Road Travel with Carrier

**NOTE**

*Do not raise the implement completely to allow the shock absorption to be effective.*

## Operation with Carrier

**NOTE**

*If the implement adapts to uneven ground with delay, turn the pressure adjuster (1) back until the pressure is reduced.*

**ATTENTION**

*On very rough terrain the pressure gauge (4) may not indicate any pressure at all.*

- Raise the implement again with the front lift by operating it briefly.
- In the case of light implements (eg rotary mower) turn the carrier off.
- Turn the star knob (3) to the right (OFF position).

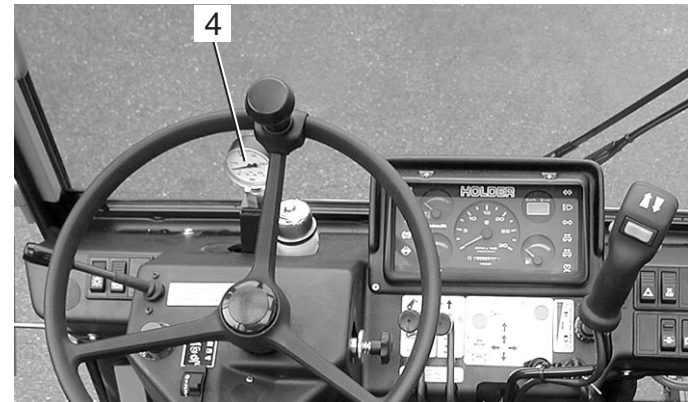
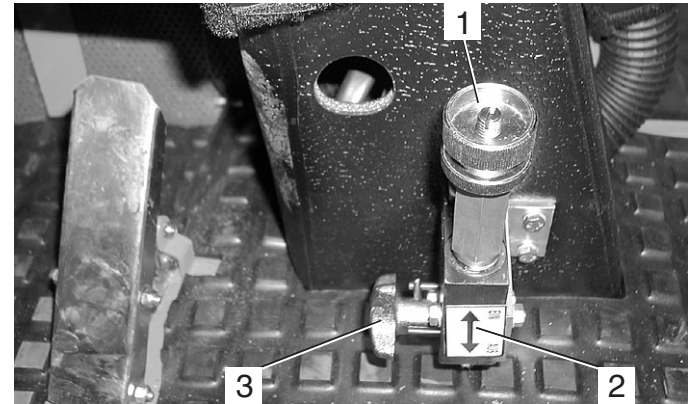

### Operating the Implements

#### Operating Variable Pump\* for Implements (setting from 0 to 100 litres)

The variable pump for the implements is a device for driving attachments with a high hydraulic power demand such as a spiral-bladed lawn mower. It draws its oil from the working hydraulics tank with a filling quantity of approx. 45 litres and is controlled from the driver's station.

- Connect the hydraulic hoses of the implements to the screw couplings (1) and (2) and the leakage oil coupling (3).
- Set the switch for the driving program (4) to one of the required driving programs.



#### NOTE

*The variable pump can not be turned on without a driving program being selected.*



#### ATTENTION

*Turn on the starting safety switch (7) only at low engine speed.*

- Set the rotary knob (5) to 0.
- Release the lock at the starting safety switch (7) and depress the switch. The indicator in the switch comes on.

\* Option

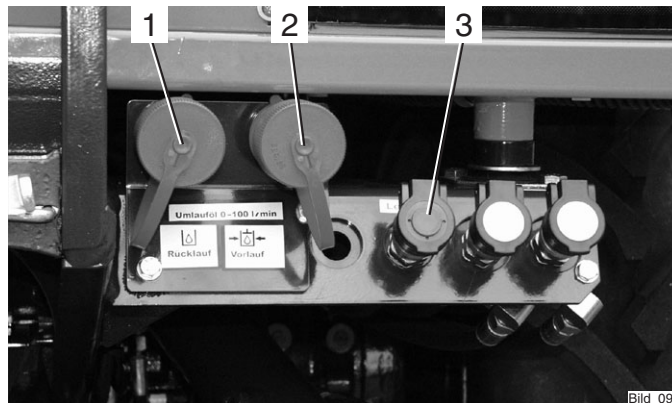

Bild\_092

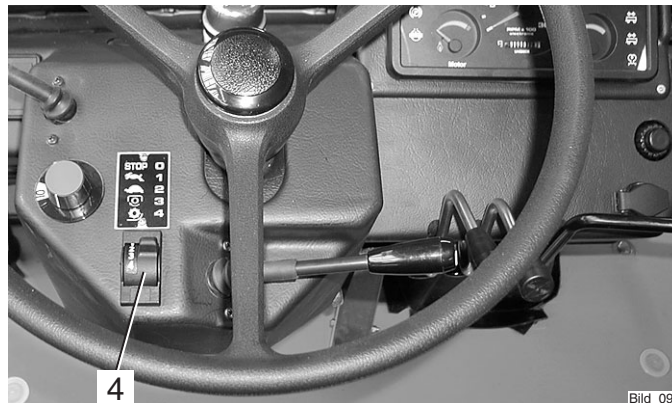

Bild\_091

## Operating the Implements

**ATTENTION**

Increase the engine speed, but then increase the oil flow only slowly.

- Turn the rotary knob (5) to adjust the oil flow from 0 to 100 litres/min until the desired flow rate for the implement is reached.  
The figure on the ring x10 corresponds roughly to the oil flow in litres per minutes at full throttle.

**NOTE**

With the setscrew at the stop ring (6) it is possible to set a stop so that a certain flow rate for an implement is not exceeded.

**ATTENTION**

If the implement is no longer used, turn the variable pump for implements off with the starting safety switch to prevent any unnecessary overheating of the hydraulic oil.

**Turning Off the Variable Pump for Implements**

- Turn off the starting safety switch (7). The indicator in the switch extinguishes.

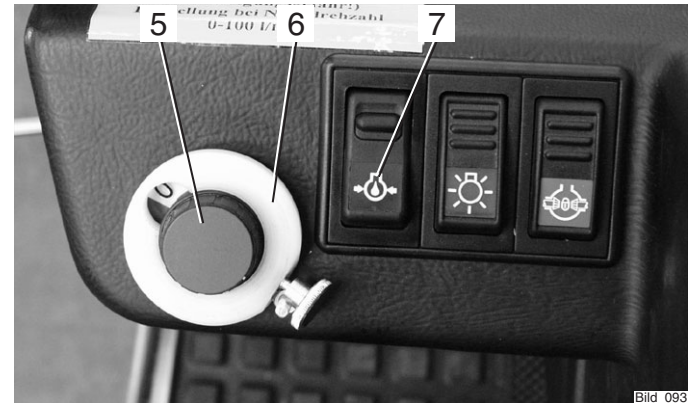

Bild\_093

**NOTE:** If the variable pump for the implements is not first switched off when you:

- turn off the engine,
- set the drive program switch to 0,
- started with the forward/reverse selector lever in the forward or reverse position

you can not, for safety reasons, immediately restart the variable pump for implements.

Before a renewed start you must either first:

- set the rotary knob to 0, or
- turn the starting safety switch off and on again once, or
- operate the forward/reverse selector lever once through neutral.

### Operating the Implements

#### Operating the Power Hydraulics\* (75 L Fixed Flow)

The power hydraulic system is used for driving attachments with a fixed hydraulic power demand. It draws the oil from the working hydraulics tank and is controlled from the driver's station.

- Connect the hydraulic hoses of the implement to the screw couplings (1) and (2) and the leakage oil coupling (3).



#### ATTENTION

Turn on the starting safety switch only at a low engine speed.

- Release the lock at the starting safety switch (4) and depress the switch. The indicator in the switch comes on.



#### ATTENTION

Increase the speed of the engine slowly.

- The implement is supplied with an oil flow of approx. 75 l/min.

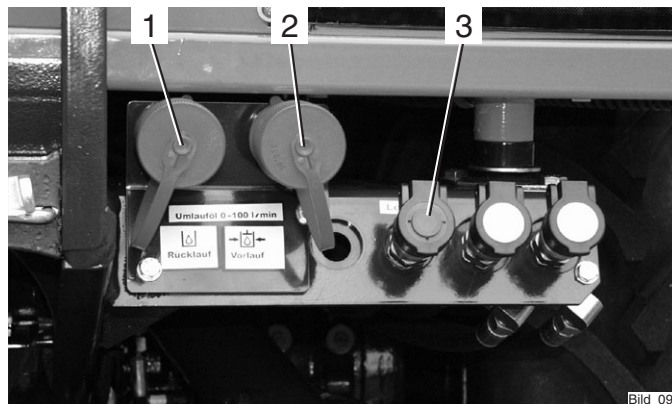

Bild\_092

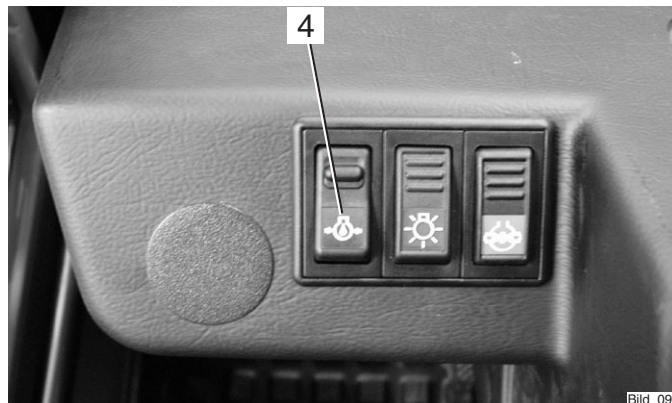

Bild\_094



**ATTENTION**

*If the implement is no longer used, turn off the power hydraulics starting safety switch to prevent any unnecessary overheating of the hydraulic oil.*

Never leave the power hydraulic system on:

- when the engine is running without a load connected to the couplings
- or not in operation,
- when driving without needing oil.

The overheating can damage the hydraulic system.

**Turning Off the Power Hydraulics**

- Turn off the starting safety switch (4). The indicator in the switch extinguishes.

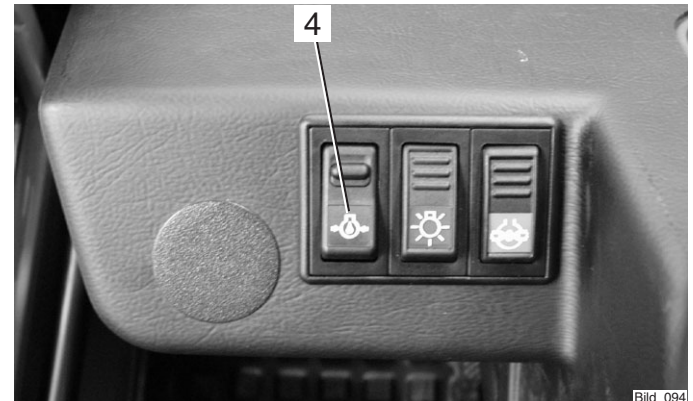

Bild\_094

### Operating the Implements

#### Operating the Hydraulic Dumper

With the hydraulic dumper it is possible to lift the dump body fast and easily. The dumper tips the loading platform\* to the rear.

- Start the engine.

Device selector lever:

- Selector lever (1) behind the seat in "dumper" position.



#### **DANGER**

*Make sure no-one standing behind the truck can get hurt.*

- Move the implement control lever (2) to the "lift" position.
  - The dumper is lifted. To stop the movement, release the control lever.
- To lower the dumper, move the implement control lever (2) to the "lowering" position.



#### **DANGER**

*Make sure no-one standing behind the truck can get hurt - danger of being crushed.*

The dumper is lowered.

\* Option

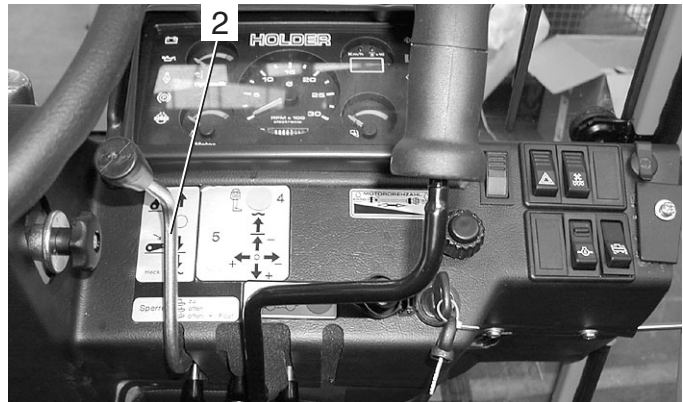

## Operating the Implements

**Operating the Oil Circulating Device\* (Rear, Unregulated)**

The oil circulating device drives the hydraulic motor of an implement with a fixed hydraulic power demand, for example a mounted road spreader in winter. It is supplied with oil from the working hydraulics tank by a tandem pump and operated from the driver's station. The implement must be equipped with its own flow regulator.

- Connect the hydraulic hoses of the implement to the red hydraulic couplings for the drive (1) and return line (2) at the rear of the tractor.

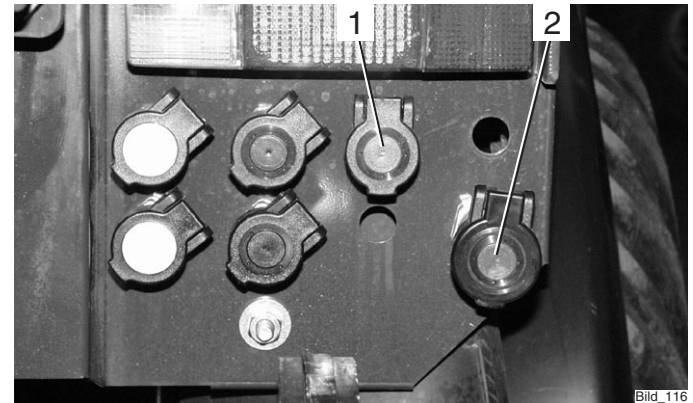

Bild\_116

**ATTENTION**

Turn on the starting safety switch only at low engine speed.

- Release the lock at the starting safety switch (3) and depress the switch. The switch engages and the indicator in the switch comes on.

**ATTENTION**

Increase the speed of the engine slowly.

\* Option



Bild\_117

### Operating the Implements

- The servo motor in the implement is supplied with an oil flow of max. 35 litres/min at a speed of 2500 rpm.



#### **ATTENTION**

*If the implement is no longer used, turn the oil circulating device off with the starting safety switch to prevent any unnecessary overheating of the hydraulic oil.*

Do not leave oil circulating device on:

- when the engine is running without a load connected to the couplings
- or not in operation,
- when driving without needing oil.

The overheating can damage the hydraulic system.

#### **Turning off the Oil Circulating Device**

- Turn off the starting safety switch (3).



Bild\_117

## Operating the Implements

## Operating Priority Flow Valve I\*

Priority flow valve I is used to drive the servo motor in an implement with a variable hydraulic power demand, for example, salt spreader, hedge cutter, etc. The working speed can be set independently of the tractor engine speed. The priority flow valve is fed by the standard working pump and is operated from the driver's station.

- Connect the hydraulic hoses of the implement to the red hydraulic couplings for the drive (2) and return line (1) at the front of the tractor.

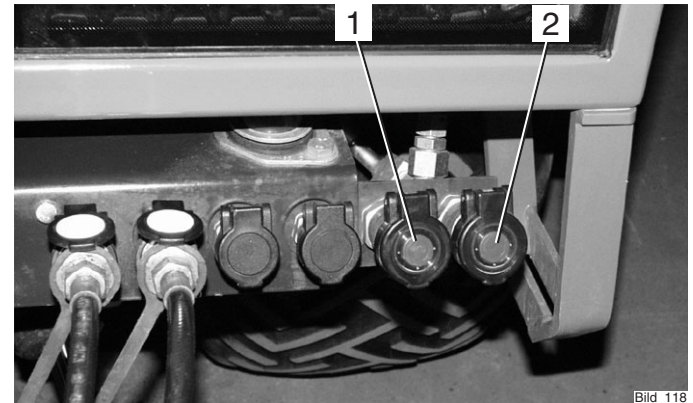

Bild\_118

**ATTENTION**

*Turn on the starting safety switch only at a low engine speed.*

- Release the lock at the starting safety switch (3) and depress the switch. The switch engages and the indicator in the switch comes on.

**ATTENTION**

*Increase the speed of the engine slowly.*



Bild\_119

\* Option

### Operating the Implements

- Select the desired engine speed with the hand throttle.
- Set the priority valve hand wheel (4) to the working speed required for the attachment.  
Turning counterclockwise increases, turning clockwise lowers the RPM.
- The servo motor in the implement is fed with an oil flow of 0 to 25 litres/min.



#### **ATTENTION**

*If the implement is no longer used, turn the priority flow valve off with the starting safety switch to prevent any unnecessary overheating of the hydraulic oil.*

Do not leave the priority flow valve on:

- when the engine is running without a load connected to the couplings
- or not in operation,
- when driving without using oil

The overheating can damage the hydraulic system.

#### **Turning Off the Priority Flow Valve**

- Turn off the starting safety switch (3). The indicator in the switch extinguishes.



Bild\_120



Bild\_119

**Operating the Implements****Operating priority flow valve II\***

Priority flow valve II is used to drive the servo motor in an implement with a variable hydraulic power demand, for example, salt spreader, hedge cutter, etc. The working speed can be set independently of the tractor engine speed. The priority flow valve is fed by the tandem working pump and set at the rear of the tractor.

- Connect the hydraulic hoses of the implement to the red hydraulic couplings for the drive (1) and return line (2) at the rear of the tractor.

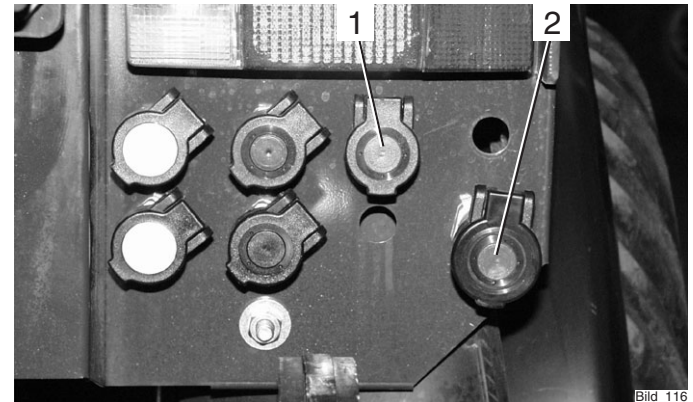

Bild\_116

**ATTENTION**

*Turn on the starting safety switch only at a low engine speed.*

- Release the lock at the starting safety switch (3) and depress the switch. The switch engages and the indicator in the switch comes on.

**ATTENTION**

*Increase the speed of the engine slowly.*

\* Option



Bild\_117

### Operating the Implements

- Adjust the desired speed of the engine with the hand throttle.
- Go to the rear of the tractor and adjust the hand wheel (4) of the priority flow valve to the working speed required for the implement.  
Turning counterclockwise increases, turning clockwise lowers the RPM.
- The servo motor in the implement is fed with an oil flow of 0 to 25 litres/min.



#### **ATTENTION**

*If the implement is no longer used, switch the priority flow valve off with the starting safety switch to prevent any unnecessary overheating of the hydraulic oil.*

Do not leave the priority flow valve on:

- when the engine is running without a load connected to the couplings
- or not in operation
- when driving without oil being required

The overheating can damage the hydraulic system.

#### **Turning Off the Priority Flow Valve**

- Turn off the starting safety switch (3). The indicator in the switch extinguishes.

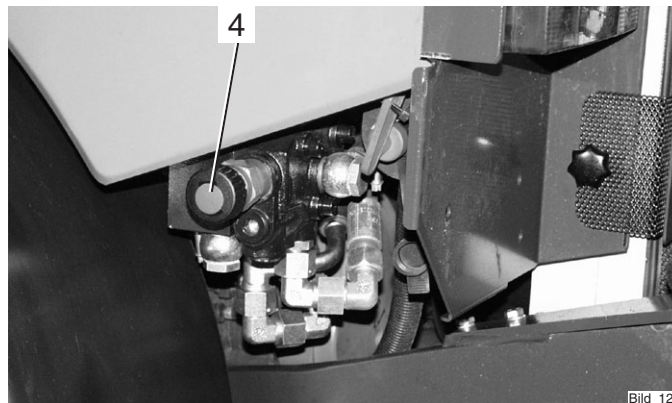

Bild\_121



Bild\_117



## Other Activities

### Operating the Driver's Cab

#### Operating the roof hatch

##### Opening the roof hatch

- Press the buttons (1 and 2) on the sides of the handle together.
- Push the handle (3) up. The roof hatch opens at the rear.

##### Removing the roof hatch

**NOTE**

*The roof hatch can be used as an emergency exit in case of danger.*

- Open the roof hatch.
- Press the inner plastic clips (1) in and out.
- Press the outer plastic clips (2) in.
- Swing the roof hatch up with the handle (3) and open to the front.

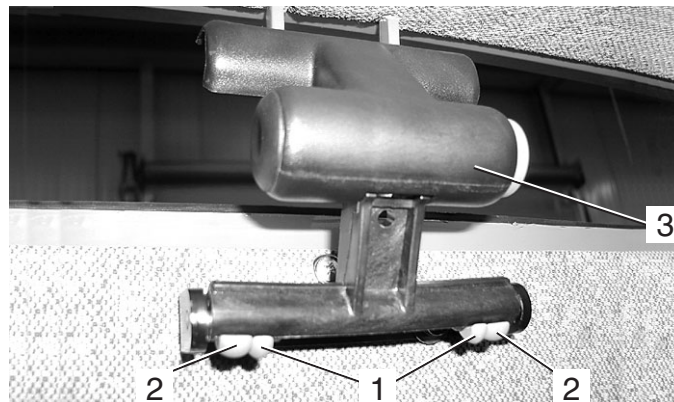
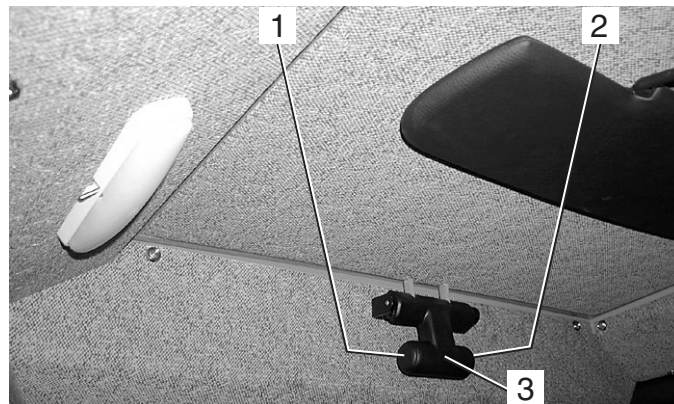

### Other activities

#### Turning on the Windshield Wiper/Washer



#### NOTE

The tractor is provided with a front and rear wiper. A washer system is also installed. The washer system is supplied with water from the washing water reservoir below the passenger seat.

#### Front Windshield Wiper/Washer

- Set the front windshield washer switch (1) to the 1st stage.  
The front wiper is in operation.
- Set the switch to the 2nd stage:  
The front windshield washer is on and only sprays as long as the switch is actuated.

#### Rear Wiper/Washer

- Set the rear windshield washer switch (2) to the 1st stage.  
The rear wiper/washer is in operation.
- Set the switch to the 2nd stage:  
The rear windshield washer is on and sprays only as long as the switch is actuated.

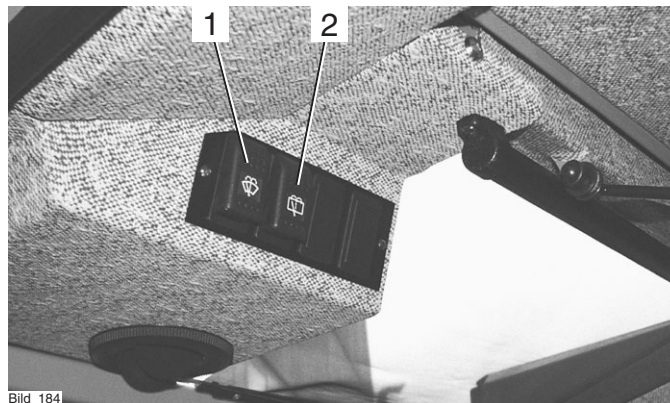

Bild\_184

## Lights

### Turning On and Operating the Lights

**NOTE**

Turn the preheat/starter switch to position 1.

- Set the light switch (1) to the 1st position.  
The front clearance lights (2, 7) and rear tail lights (9, 14) (sidemarker light) are on.
- The position light indicator (2) in the multi-function display comes on.
- Set the light switch (1) to the 2nd position  
The front headlights (1, 8) (dip beam) are on.

### Turning On High Beam

- Set the light switch (1) to the 2nd position.
- Move the turn signal lever (4) down. The headlights (1, 8) are set to high beam.
- The high beam indicator (3) in the multi-function display comes on.

**NOTE**

To use the headlight flasher, operate the signal lever up.

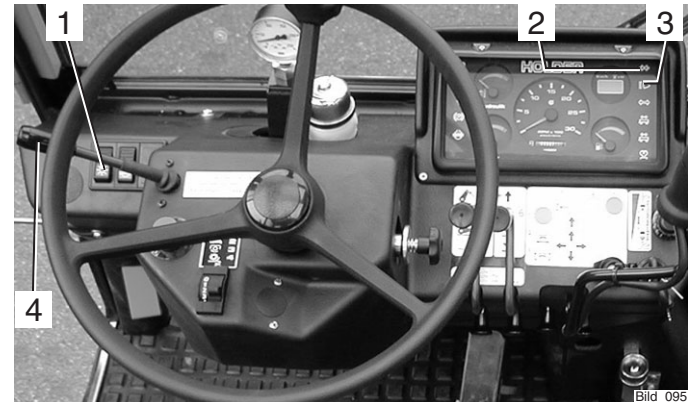

## Other activities



- 1 Head light
- 2 Clearance light, RH
- 3 Turn signal light, RH
- 4 Head light, up
- 5 Head light, up
- 6 Turn signal light, LH
- 7 Clearance light, front
- 8 Headlight, front
- 9 Stop light
- 10 Tail light, turn signal light, LH
- 11 Reversing light
- 12 Rotating beacon mount
- 13 Flood light\*
- 14 Stop light
- 15 Tail light, turn signal light, RH
- 16 Reversing light
- 17 License plate light



### Turning on the Upper Lights



#### NOTE

If front implements are installed and the bottom headlights are hidden, it is possible to turn on the upper lights. If these headlights are on, drive only at a maximum speed of 25 km/h.

- Operate the upper headlights switch (1).
- The upper headlights (4, 5) are on.



#### NOTE

The functions high beam and headlight flasher are only available in the lower headlights.

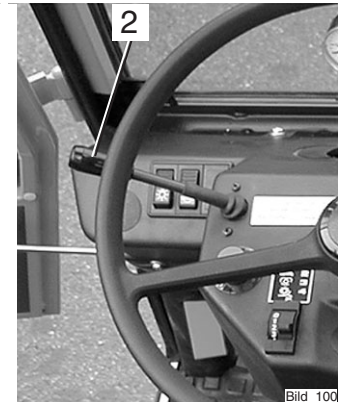
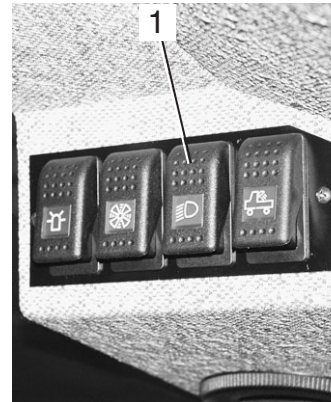

Bild\_100

### Right and Left Turn Signal

- Set the turn signal lever (2) back. The left turn signal lights (6, 9) are on.
- The turn signal indicator in the multi-function display flashes.
- Move the turn signal lever (2) forward. The right turn signal lights (3, 14) are on.

### Operating the Horn

- Push in the turn signal lever (2) to sound the horn.

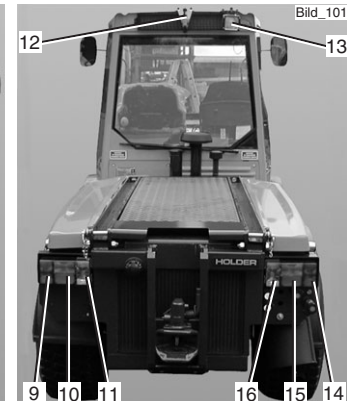

Bild\_101

### Other activities

#### Turning on the Hazard Warning Flasher System

- Operate the hazard warning flasher switch (2) to turn on the hazard warning lights.



Bild\_103

#### Turning on the Rotating Beacon\*



#### NOTE

*The rotating beacon may only be turned on if the tractor is used for applications on public roads.*

- Operate the rotating beacon switch (1).  
The rotating beacon (12) is on.

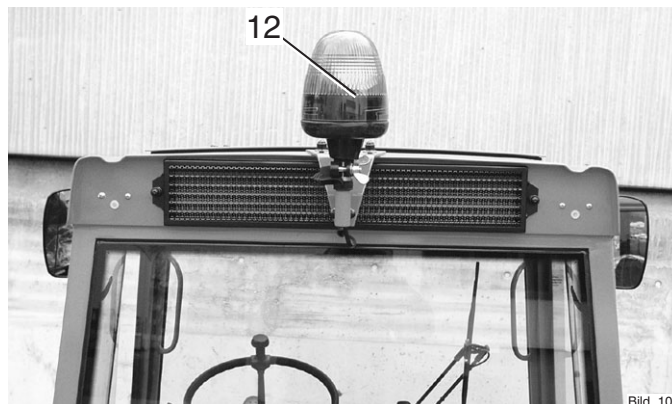

Bild\_102

\* Option

## Other activities

### Turning on the Flood Light\*



#### **NOTE**

*The flood light should not be used in the public traffic area.*

- Operate the flood light switch (4).  
The flood light (13) is on.

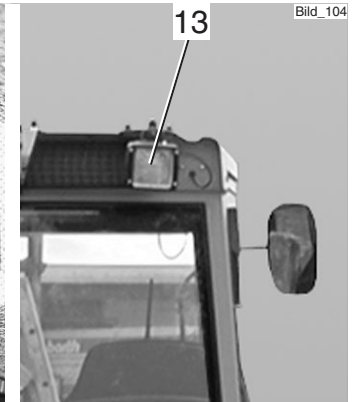
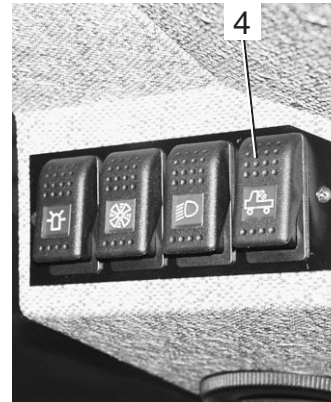

### Interior Light

#### Turning on the Interior Light



#### **NOTE**

*There is an interior light on the left and right in the cabin roof.*

- To turn on the interior lights, move the switch (1) forward.



\* Option

### Other activities

#### Radio\* and Loudspeaker\*

##### Operating the Radio



##### NOTE

There is a separate operating manual for the radio (1).

Please observe the instructions in this manual for operation of the radio.

The loudspeakers (3) are installed at the rear in the roof of the cabin.

##### Power Socket

##### Connecting Equipment to Power Socket

- You can connect 12 VDC equipment with maximum power rating of 15 A to the power socket (2) with a commercial automotive plug.



##### ATTENTION

Do not leave the equipment running unattended; If the engine is not running, the battery can be discharged.

\* Option

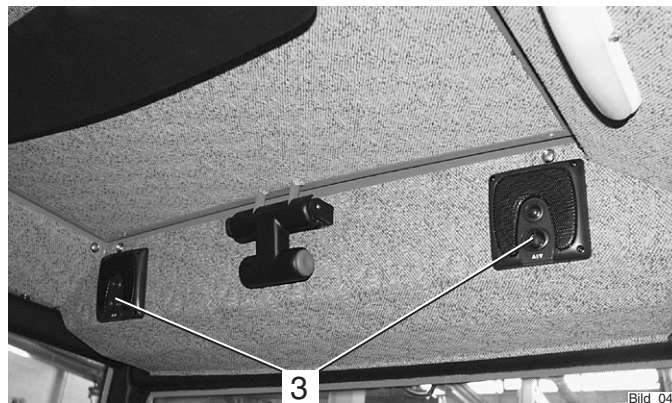

Bild\_042



## Heating

### Heating and Ventilation

#### Turning on the Heating

**NOTE**

*The cabin heater is heated by the engine cooling oil.*

- To heat the cabin, turn the heat shut-off valve (1) up. Any intermediate position is also possible. Lever up increases the heating effect, lever down reduces it. Observe the plate (2) beside the heat shut-off valve.
- To shut the heating off, move heat shut-off valve lever fully down.

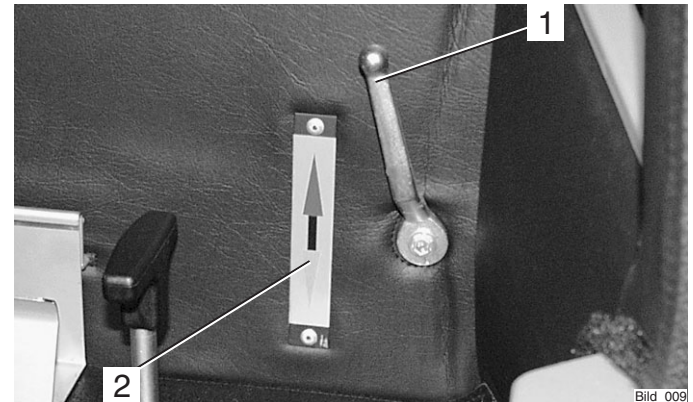

Bild\_009

### Other activities

- To heat the cabin, toggle the heater blower switch (2).



#### NOTE

*The heater blower has two speeds.*

- Position 1      Slow (only air circulation in the cabin)
- Position 2      Fast (heater blower at high speed, roof blower at slow speed)

There are several air vent nozzles fitted in the cabin:

- 2 in the cab roof at the front
- 1 behind the driver's seat
- 4 at the instrument panel for the front and side windows
- 2 low down at the front in the foot area
- Set the air vent nozzles to the desired direction and desired air flow.

### Turning on the Ventilation System

- To ventilate the cabin, operate the fresh air blower switch (1).



#### NOTE

*The fresh air blower (top) has 2 speeds.*

- Position 1      Slow
- Position 2      Fast (for summer)

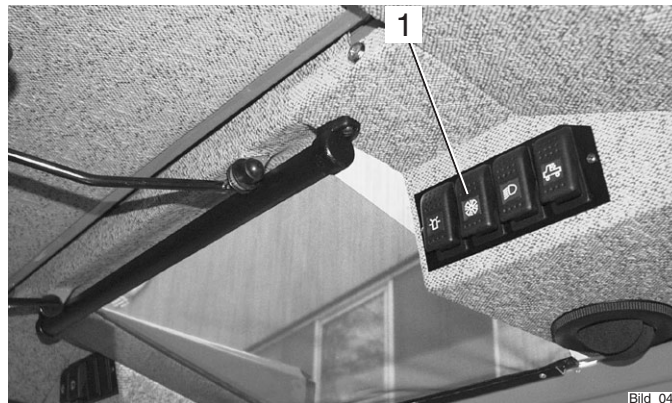

Bild\_044



Bild\_045

## Air Conditioner

### Operating the Air Conditioner\*

**NOTE**

*A separate operating manual is supplied for the air conditioning.*

*Please observe the instructions in this manual for operation of the air conditioning.*

*The air conditioner is protected with its own 25 A fuse located in the compartment at the left behind the cabin.*

### Air Conditioning\*

- 1 Switch for 4-speed blower
  - 2 On/Off switch
  - 3 Temperature control
  - 4 Air vent nozzle, adjustable
- Set the air vent nozzles to the desired direction and to the desired air flow.

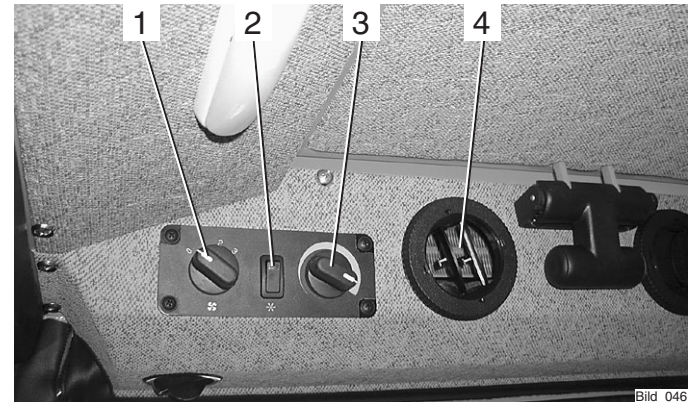

\* Option

## Other activities

### Fuses



#### CAUTION

Before carrying out any work on the electrical equipment, for example, replacing the fuses, always turn the battery isolating switch off.

### Fuses for the Tractor



#### NOTE

The fuses for the tractor are installed below the instrument panel at the right-hand side. To gain access to the fuses, remove the cover.

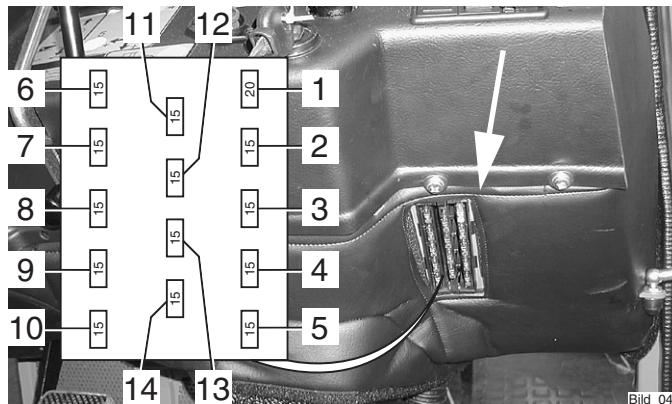

- |   |   |
|---|---|
| <ul style="list-style-type: none"><li>1 Hazard warning flasher system<br/>Cab interior light /radio 30/cigarette lighter</li><li>2 Sidemarker light 58R/multi-function display light</li><li>3 Sidemarker light 58L, auxiliary lighting</li><li>4 Dip beam</li><li>5 High beam/high beam indicator</li><li>6 Stop light</li><li>7 Optional light switch/pressurizing valve<br/>diff. lock/headlight flasher</li><li>8 Heater blower motor</li></ul> | <ul style="list-style-type: none"><li>9 Digital display for driving speed/PTO</li><li>10 Solenoid valve for circulating oil/multi-function<br/>display 15</li><li>11 Horn/engine shutdown solenoid via relay 72</li><li>12 2-pole socket/radio/cigarette lighter/<br/>electric seat adjuster</li><li>13 Turn signal lights</li><li>14 Electronics box 15 Hydrostatic<br/>drive forward/reverse switch</li></ul> |
|---|---|

**Fuses for the Cabin****NOTE**

The fuses for the cabin are located on the console at the top right.

To gain access to the fuses, remove the cover.

**Fuses for the Cabin**

- 1 Right and left interior light, 15 A
- 2 Rear wiper/washer system 15 A
- 3 Front wiper/washer system 15 A
- 4 Flood light 15 A
- 5 Fresh air blower 15 A
- 6 Rotating beacon 25 A

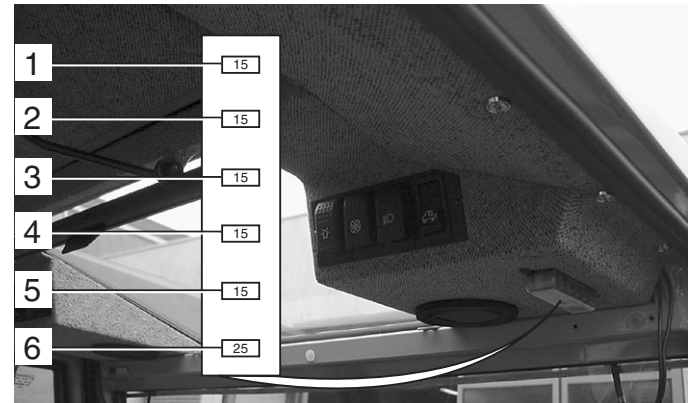
**Fuse for Air Conditioning\*****NOTE**

In the compartment at the left behind the cabin.

To gain access to the fuses, screw off the cover on the left behind the cabin.

- 1 Fuse 25 A
- 2 Air conditioner relay

\* Option

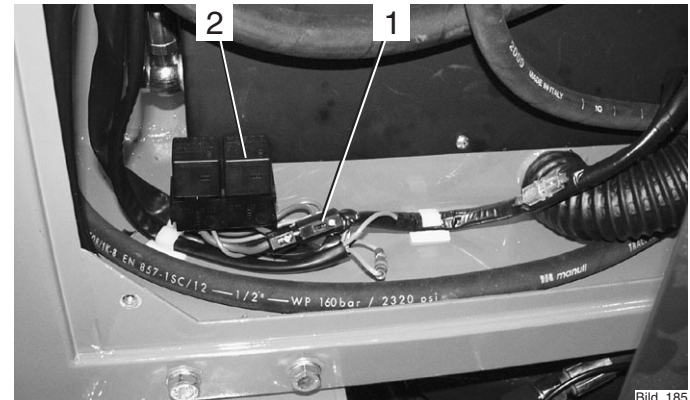

Bild\_185



## Taking out of Operation

### Leaving the Tractor

#### Stopping the Tractor

- Lower the implement completely.
- Engage the parking brake.
- Push in the hand throttle (1) fully (idle position).
- Set the forward/reverse selector lever to 0.
- Set the drive program switch to 0.

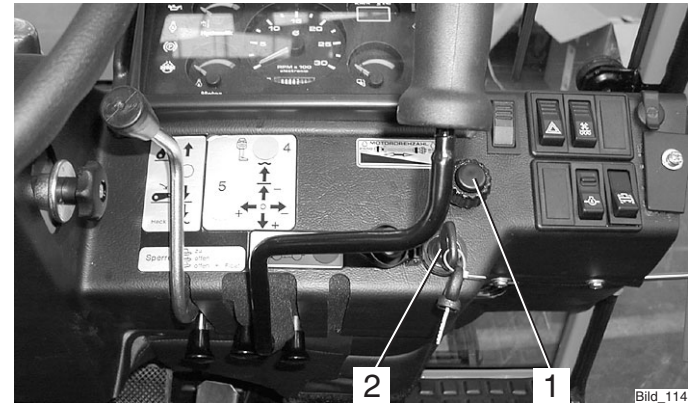

#### **ATTENTION**

*If the engine is overheated (engine temperature gauge (3) in the red field), let the engine run without a load until the temperature has dropped to the green area. Do not let the engine run unattended!*

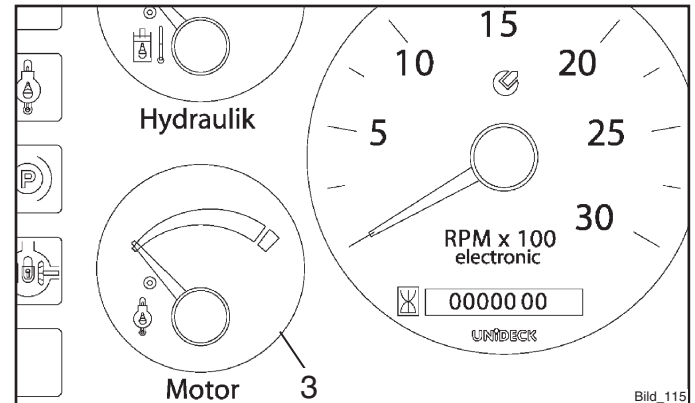

### Taking out of Operation

#### Parking



#### ATTENTION

*If the tractor is parked on slopes, it must be secured against rolling with chocks.*

- Put the tractor in a low gear (only if equipped with a gearbox).
- If equipped with a hydrostatic drive, also secure the tractor with chocks.
- Turn the ignition key (2) to the left to 0 to turn the engine off.
- Remove the ignition key and take it along.

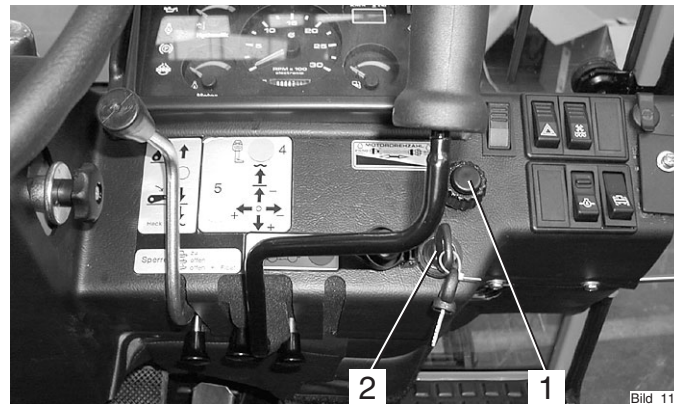

Bild\_114



#### CAUTION

*Do not leave the cabin without taking the ignition key.*

- Turn off the battery isolating switch (3) and take the key with you.



Bild\_111

#### Leaving the Tractor

- Lock the cab door(s) with the key.
- If necessary, secure the tractor against rolling with chocks.



## Trailers, Towing

Your tractor can tow the following trailers:

**Table of Trailers**

Type of Trailer	Permissible Total Weight	Braking System
Single axle trailer	2.5 t	No braking system
Single and multiple axle trailer	Up to 4 tons	With own braking system if the trailer brake lever can be mounted easily accessible beside the driver's seat
Single axle trailer	Up to 4.5 tons	With overrunning brake
Multiple axle trailer	Up to 4.5 tons	With service brake system and parking and rapid-emergency brake
Trailer	Up to 12 tons	With hydraulic or pneumatic braking system



**NOTE:** A pneumatic braking system is available as option.

The following trailer combinations are allowed:

- 1 Tractor plus single-axle trailer with brake or without brake
- 2 Tractor plus single-axle trailer with brake or without brake plus two-axle trailer with override brake.
- 3 Tractor plus two-axle trailer with brake plus two-axle trailer with override brake.
- 4 Tractor plus two trailers with override brakes, plus single-axle trailer plus two-axle trailer, or two-axle trailer plus two-axle trailer



**NOTE:** The total length of the tractor-trailer train should not exceed 18 m.

## Trailers, Towing

### Operating the Trailer Hitch, Attaching Trailers

- Adjust the height of the trailer hitch (2) at the adjustment rail (1) so that the trailer tiller can be attached horizontally.
- To adjust the height, pull the lever (6) up.

### Bearing Load



**ATTENTION:** The bearing load must be at least 25 kg (4 % of the trailer load), while the maximum bearing load must not exceed 800 kg.

If the bearing load is underrun or exceeded when unloading the trailer, the load must be shifted so that the bearing load returns to the permissible range.

- Drive the tractor in front of the trailer to be attached.



**DANGER:** The trailer must be secured against unintentional movement (rolling).

- Pull the release lever (4) up until the tow pin (3) is clear of the hitch.



### **DANGER**

Be sure no-one is standing between the tractor and trailer.

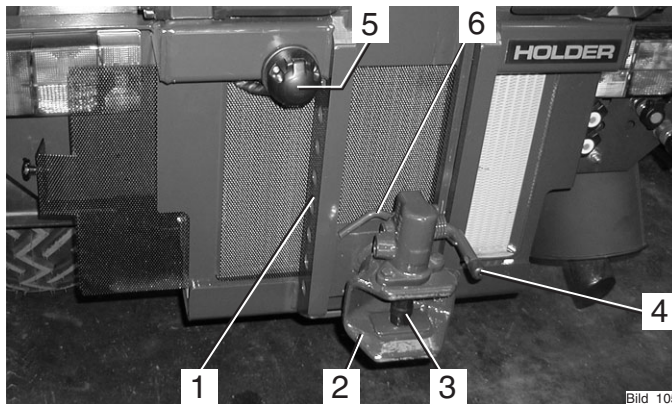

Bild\_105

- Drive the tractor with the hitch in the trailer tiller. Upon contact, the hitch closes, the towing pin (3) goes through the eye of the tiller.



### **DANGER**

The trailer hitch must be completely closed.

- Connect the trailer lighting to the socket (5).
- Remove the wheel chocks from the trailers.

### Driving with Trailers

- Set the driving range pre-selection lever (1) to position S or L. The tractive force is greater in position L.
- Drive the tractor as described in the section on driving.



#### **DANGER**

*If a trailer not requiring a permit is attached, the driving speed is limited to 25 km/h. The trailer must be identified with a 25 km/h sign.*





## Transport, Loading, Towing

### Instructions for Transport

- Drive the tractor on the means of transport.
- Park the tractor as described in the section on leaving the tractor.
- Secure the tractor against rolling with chocks at the wheels and, if needed, with wood blocks at the side to prevent it from sliding to the side.
- Lash the tractor at the front to the upper link support (1), at the rear to the towing device (2).



### Instructions for Loading



#### **DANGER**

*When hoisting the tractor, only use lifting equipment and a crane with a sufficient load capacity.*

- The hoisting weight should not exceed the permissible total weight:

The hoisting weight is given on the tractor identification plates or in the tables of weights in the Technical Data.

- Hoist the tractor only with the lifting equipment attached to all 4 wheels.



**DANGER:** Do not step or stand under a suspended load. Danger of loss of life!

### Transport, hoisting, towing

#### Instructions for Towing

If your tractor can not drive on its own power because it is damaged, it can be towed. Use the upper link support at the front at the driver's cab for towing.



**DANGER:** The towing tractor must have sufficient tractive and braking force for the towed load without brakes.

- The towed load must not exceed the permissible total weight.  
The total weight of the vehicle is given on the identification plate or in the tables of weights in the technical data.
- Attach the towing device (in case of failure of the brake only a rigid tow bar) to the upper link support (1).
- Set the forward/reverse selector lever to the centre position (no direction of travel selected).
- Shift the gear and range selector lever to neutral (gearbox).
- Set the driving range pre-selection lever to position 0 (hydrostatic drive).
- Let the engine run so that the power steering is operational.

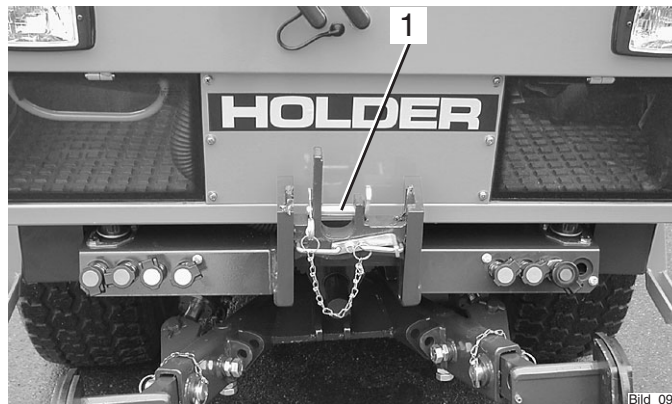

**CAUTION:** If the engine is not running during towing or the hydraulic system has failed, steering is difficult. Increased effort is required for steering in this case.

- Tow the tractor at a maximum of 10 km/h to the nearest authorized workshop.
- Park the tractor secured against rolling.

## **Indicators, Adjustments**

### **Adjusting the Speedometer**

The adjustment of the speedometer in the multi-function display is required when changing from large to small tires and vice versa.

Please refer to the maintenance manual for the adjustment of the speedometer.





## Problems, Cause, Remedy

The following tables list problems and their possible causes. If you can not carry out the remedy yourself, please contact an authorized workshop or our customer service. Test and Control Box BB3, with which further troubleshooting/ diagnostics are possible, are available as option.

## Problems in Engine and Exhaust Gas Turbo-charger

Please observe the notices in the operating manual for the engine.

## Problems in Electronic and Hydraulic Drive System

Malfunction	Cause	Remedy
Tractive force too low	Feed pressure too low	Check valve!
	High pressure too low	Check high pressure valves
	Variable pump or variable motor leakage too large	Repair variable pump or variable motor
No forward or reverse travel possible	Drive or power take-off defective	Repair
	No feed pressure	Check feed pump
	Control cylinder in variable pump stuck	Replace variable pump

## Malfunctions, cause, remedy

<b>Problem</b>	<b>Cause</b>	<b>Remedy</b>
No forward and reverse travel.	Range selector lever in neutral	Select working or transport range
	Forward/reverse selector switch in neutral	Put forward/reverse selector switch in desired direction of travel
	No power supplied to the electronics	Check fuses Check electrical connection
	Electrical connections to variable pump interrupted	Make connection
	Electrical connection of Diesel engine - speed sensor interrupted, possibly oxidized	Make connection
	Accelerator potentiometer defective	Renew accelerator potentiometer and adjust with BB3
	Diesel engine speed sensor defective	Replace sensor
	Forward/reverse selector switch defective	Replace Forward/reverse selector switch
	Drive program switch at 0	Select desired driving program

**Malfunctions, cause, remedy**

<b>Problem</b>	<b>Cause</b>	<b>Remedy</b>
Tractor drives only in one direction	Forward/reverse selector switch defective	Replace forward/reverse selector switch
	Electrical connection to the variable pump interrupted	Make connection
No maximum speed	Diesel engine does not attain maximum RPM	Check accelerator linkage Check Diesel engine
	Inch pedal not at maximum speed	Adjust inch pedal and/or inch pot, calibrate
	Variable pump not at full delivery	Check maximal current Check proportional solenoid
	Sensor for ground speed defective, adjust electrical connection if required	Check or replace sensor, check electrical connection
Does not remain stationary when inch pedal is fully depressed	Inch pedal at wrong position, maybe foreign objects in actuator	Adjust properly, remove any foreign objects
	Inch pot not adjusted properly	Adjust inch pot, calibrate

## Malfunctions, cause, remedy

Problem	Cause	Remedy
Inch pedal not functioning	Inch pot defective	Replace inch pot, calibrate Repair cable connection
Tractor does not remain stationary in driving program 1 or 2 without operation of accelerator	Idling speed of the engine too high. (reaches starting RPM)	Adjust idling speed, check actuator
	Incorrect calibration	Carry out calibration

## Problems in the Hydraulic System and Steering



### NOTE

*These notices only apply for valve arrangements conforming to our circuit diagrams or approved by Bucher.*

Problem	Cause	Remedy
Lifter or hydraulic cylinders not lifting, although control valve can be moved normally. No build-up of pressure (steering working normally)	Pressure relief valve jammed due to foreign objects	Remove and clean pressure limitation valve LU 08 SCS-OM2, but do not change the pressure setting!
Loss of lifting power	Pressure setting too low Oil level too low	Reset pressure with pressure gauge (190 bar) Fill up specified type of oil
Operating pressure is only reached with high RPM	Pump defective	Replace pump
Manual control valve jammed	Radial torsion  Dirt	Tension screws too tight or not all tightened to the same torque Maximum torque 25 Nm (2.5 mkp) Remove and clean valve

## Malfunctions, cause, remedy

Problem	Cause	Remedy
Hydraulic oil heats too quickly, system works against excess pressure (engine under load)	Control valve jammed. Control lever remains in operated position (Does not automatically return to neutral position) Cylinder at limit stop  No implement attached, but control lever operated (coupling)	Adjust as above  Put valve in neutral position (free circulation) Put valve in neutral position (free circulation)
Hydraulic oil foams	Leaks in the suction range	Check all pipe connections and tighten, if required
Hydraulic system working too slowly, accompanied by whistling noise	Hydraulic oil level too low Temperatures too low	Fill up as specified Replace with proper type of oil as specified in maintenance manual
Steering not working	Priority flow valve dirty  Relief valve in hydraulic steering not closing	Remove the priority flow valve at the steering and clean it Remove and clean (authorized workshop)
Lost steering motion when steering direction is changed rapidly	Leaks in steering return line	Tighten return flow hose

## General Remarks on Maintenance

To keep your tractor always in peak condition, we would ask you to study the information in this maintenance manual very carefully. These chapters contain all the information you need for a conscientious treatment and care of the tractor. Take care to have your tractor serviced at the proper intervals.

## Service

Please have all scheduled tractor services (acc. to maintenance schedule) and repairs carried out regularly by your dealer (authorized workshop) and confirmed with a stamp and signature in this maintenance manual.

Detach the double guarantee card filled in by the dealer signed by the customer directly to

Gebrüder Holder GmbH  
P. O. Box 15 55  
72545 Metzingen/Württ.

Warranty and product liability can only be claimed if the maintenance services and inspections have been carried out punctually and regularly.

## Qualification of the Service Personnel

The tractor, together with its attachments, may only be used, serviced and repaired by persons familiar with this equipment and have been warned of possible risks.

The qualified personnel entrusted with the work must have the required tools.

The applicable safety regulations and rules must be observed.

## How to Value the Tractor?

As you know, a car is judged by its age together with the number of kilometres driven. The way to judge a tractor is to consider its age together with the number of service hours according to the following table:

<b>Service Hours</b>	<b>Kilometers Driven</b>
1	50
10	500
150	7500
300	15000
600	30000
1500	75000

**General Remarks on Maintenance****Service**

The following services were carried out:

In the maintenance table below you can enter the properly carried-out services and inspections and have them confirmed.

(These entries are required to keep your warranty claims intact):

<b>Service Interval</b>	<b>Hours of Operation</b>	<b>Date</b>	<b>Signature</b>
125			
250			
375			
500			
625			
750			
875			
1000			
1125			
1250			
1375			
1500			

<b>Service Interval</b>	<b>Hours of Operation</b>	<b>Date</b>	<b>Signature</b>
1625			
1750			
1875			
2000			
2125			
2250			
2375			
2500			
2625			
2750			
2875			
3000			



### Handling fuels and lubricants

- Fuels and lubricants must always be handled properly and as specified by the manufacturer.
- Fuels and lubricants may only be stored in approved containers at specified places of storage. They can be inflammable, therefore do not allow them to come in contact with hot objects or with naked flames.
- Exercise caution when handling fuels - increased danger of fire. Do not fill any fuels in the vicinity of naked flames, ignition sparks or hot engine parts. No smoking when refuelling!
- Before refuelling, shut off the engine and remove the ignition key. Do not run the engine in enclosed spaces. Do not spill fuels! (use suitable filling aids).
- Exercise caution when handling brake fluid and battery acid (poisonous and corrosive).
- Only use clean vessels when filling fuels and lubricants.
- When using fuels, lubricants and cleaners, follow the safety and disposal instructions of the manufacturer.
- Always avoid spilling. Eliminate spilled brake fluid immediately with a suitable binding agent and discard as specified by regulations.
- Oils, fuels, batteries, brake fluid and filters must be disposed of separately and as specified by regulations.

### General Remarks on Maintenance

- Before beginning lubrication, changing filter or opening the hydraulic system, clean the area surrounding the affected part carefully.
- Replaced parts must be discarded in a way friendly to the environment.
- Observe all local and national laws and regulations.



#### **CAUTION**

*The penetration of hydraulic oil under pressure into the skin, eg through leaks, is dangerous. If such injuries occur, seek medical aid.*

### Safety Notes for Maintenance

Observe the instructions in this maintenance manual and the general applicable safety and accident prevention rules!

- Do not allow anyone to stand around where they might get hurt!
- When starting the engine, the traction and implement drive must be shut off!
- Start the engine only from the driver's station. Do not start the engine by short circuiting the starter terminals, as the machine could start moving immediately.

## General Remarks on Maintenance

- Do not run engine in enclosed spaces! Danger of poisoning!
- To prevent the danger of fire, keep the tractor and implements clean!
- When leaving the tractor, secure it against rolling and unauthorized use (parking brake, chocks), stop the engine, remove the ignition key and, if required, lock the cabin.
- Do not leave the tractor unattended as long as the engine is still running.
- If external current consumers are connected, eg equipment with solenoid valves, protect them with diodes against back currents. If not, the traction electronics could be affected.
- Operate the equipment only if all guards are installed and in position.
- Install and remove the cardan shaft only with the engine stationary.
- When working with the PTO shaft, no-one should be standing in the area of the rotating PTO and cardan shaft.
- The guards for the cardan shaft and the PTO shaft must be installed as specified.
- When the cardan shaft is removed, refit the protective cap on the PTO shaft.
- Do not perform any welding, cutting and grinding work on carrying and other safety-relevant parts such as tractor frame, axles, trailer hitch, etc.
- The mounting of tires requires sufficient knowledge and special mounting tools.
- Only use genuine spare parts or qualitatively equivalent, commercially-available parts. Use the parts in the list of maintenance parts in the chapter entitled "Maintenance Data".
- Before taking into service and after servicing or repair, the tractor and the implement must be checked for road worthiness and operating safety.

## General Remarks on Maintenance

### Work on the Electrical Equipment

Before performing any services on the electrical equipment, switch off power with the battery isolating switch (1).

- The switch must be horizontal, the toggle removed.

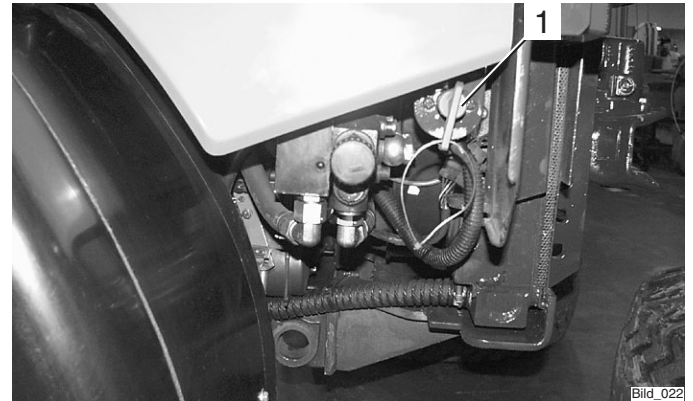

Bild\_022



### **CAUTION**

*Disconnect the battery ground lead (2).*

Do not place any metal parts on the battery terminals. Risk of short circuit!



Bild\_170

### General Remarks on Maintenance

#### Jack Lifting Points

##### Jacking Up



##### **DANGER**

*When using the jack, be sure the tractor is shut down and secured against rolling (chocks)!*

The tractor may only be jacked up at the shown locations (1 and 2).



##### **DANGER**

*The weight to be lifted should not exceed the permissible load capacity of the jack.*

When carrying out repairs, the raised tractor must also be secured against lowering with supports. Place the supports under the axles on both sides.

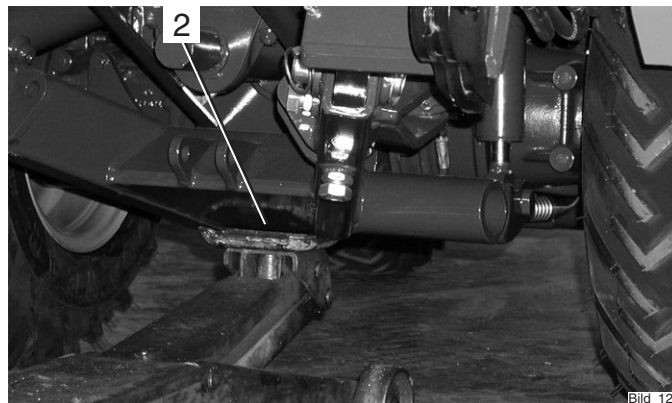

**General Remarks on Maintenance****Securing the Frame (Loading Platform\*)**

For all services requiring the dump body (loading platform\*) to be raised, secure it against accidental lowering.

- Place a U-channel on the cylinder and secure it with locking pins (1).

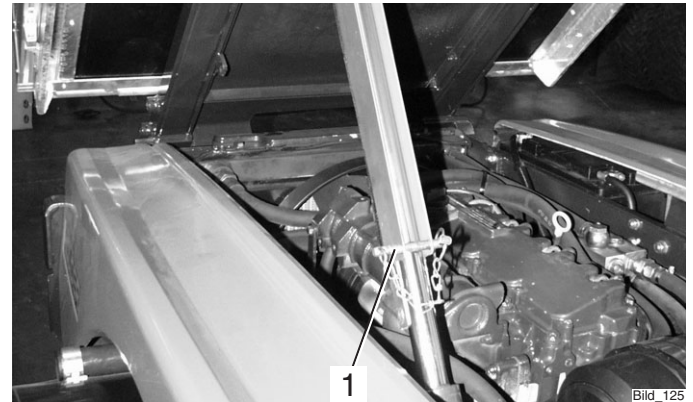

\* Option



## Maintenance Schedule

### Maintenance during the First Period of Operation

Interval	Service and Inspection	See page
<b>Maintenance after the first 50 service hours</b>	Check engine for leaks	161
	Check hydraulic oil level	50
	Renew hydraulic oil filter (pressure filter for implement hydraulics)	180
	Renew hydraulic oil filter (pressure filter for drive hydraulics)	179
	Check clutch	172
	Check brake system	172
	Lubricate tractor	173, 185
	Retighten screws and studs	174
	Retighten wheel nuts	174
<b>Maintenance after the first 150 service hours</b>	Change gear oil of front gearbox	187
	Change gear oil of rear gearbox	189
<b>Maintenance after the first 500 service hours</b>	Change hydraulic oil for drive hydraulics	191
	Change hydraulic oil for implement hydraulics	193
	Check or clean hydraulic oil suction filter of implement hydraulics	191
	Check or clean hydraulic oil suction filter of drive hydraulics	194
	Change hydraulic oil return filter for variable pump	166
	Change hydraulic oil return filter for power hydraulics	167

The services and inspections specified below must be carried out after the stated number of service hours is reached. The services and inspections of the lower intervals must be carried out at the same time.

Example:

At 1000 hours of operation, the services and inspections for 500 and 125 service hours must also be carried out.

## Maintenance Schedule

### Regular Maintenance

#### Service and Inspection

Maintenance as required

Adjust speedometer  
Check air cleaner system  
Change hydraulic oil return filter for variable pump  
Change hydraulic oil return filter for power hydraulics

### Periodic Maintenance

Maintenance every 125 service hours

Check cooling system  
Clean cooling system  
Check battery and cable connections  
Check hydraulic oil level, see page 52  
Check high pressure hoses  
Check steering cylinder and orbitrol  
Check brake fluid level for the foot brake  
Check clutch brake fluid level  
Check clutch  
Check PTO clutch  
Check brake system  
Lubricate tractor  
Retighten screws and studs  
Retighten wheel nuts  
Check electrical system  
Clean fresh air filter

Maintenance every 500 service hours

Change engine oil  
Change engine oil filter  
Check hose couplers for leaks  
Change hydraulic oil pressure filter (drive hydraulics)  
Change hydraulic oil pressure filter (implement hydraulics)  
Check heater



<b>Periodic Maintenance</b>	<b>Service and Inspection</b>
<b>Maintenance every 1000 service hours</b>	Check valve play Check battery Check V-belt tension and condition Change fuel filter Clean or change star filter of fuel feed pump Lubricate cardan shaft nipples
<b>Maintenance every 1500 service hours</b>	Change gear oil of front gearbox (including axles) Change gear oil of the rear transmission (including axles) Change hydraulic oil for drive hydraulics Change hydraulic oil for implement hydraulics Check or clean hydraulic oil suction filter of implement hydraulics Check or clean hydraulic oil suction filter of drive hydraulics Change hydraulic oil return filter for variable pump, see page 160 Change hydraulic oil return filter for power hydraulics, see page 161
<b>Maintenance every 3000 service hours</b>	Check injection nozzles Change toothed belt
<b>Annual Maintenance</b>	Examine hydraulic oil samples of implement hydraulics Change hydraulic oil for drive hydraulics
<b>Maintenance every 2 years</b>	Change hydraulic oil for implement hydraulics



## **Maintenance during the First Period of Operation**

During the first period of operation the following services and inspections are due:

Maintenance after the First 50 Operating Hours  
Maintenance after the First 150 Operating Hours  
Maintenance after the First 500 Operating Hours

### **Maintenance after the First 50 Operating Hours**

#### **Check the Engine for Leaks**

- Raise the dump body (loading platform\*) and secure against accidental lowering.
- Check the engine and implements for leaks.

Carry out the other services in accordance with the maintenance schedule. You can find the description of the services in the maintenance schedule page reference or in the alphabetical index.

\* Option



## Maintenance as Required

### Adjusting the Speedometer

The adjustment of the speedometer in the multi-function display is required when changing from large to smaller tires and vice versa.

- Remove the sun protection frame (1).
- Disengage the lock on the left (2) and right (3) side of the frame with a screwdriver.
- Pull the multi-function display (4) out and turn it around.
- Remove the cover from the combination switch (5) on the back.
- Set the 6 DIP switches to the positions shown in the table as required for the size of your tires.
- Note the combinations column applicable for your display.



#### **NOTE**

*There are 2 different columns for the possible combinations. The first column applies for the tractor with gearbox, the second one for the Hydrostatic Drive and Dual Drive.*



Bild\_146

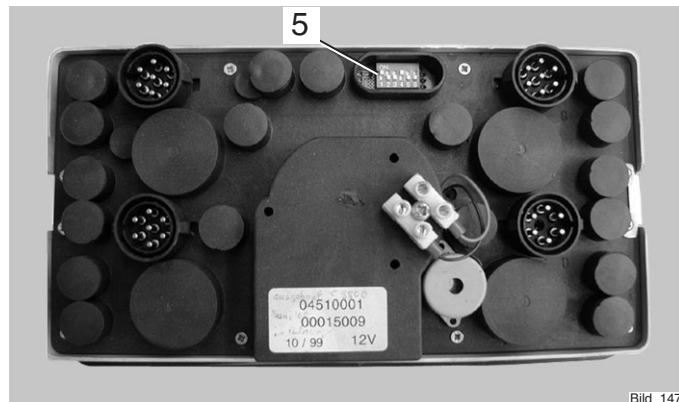

Bild\_147

## Maintenance as required

Switch Arrangement Tire Size	Type	Gearbox						Hydrostatic Dual Drive					
		Combination						Combination					
		1	2	3	4	5	6	1	2	3	4	5	6
36x13,5-15	524-31-8	0	1	0	1	1	0	1	0	0	0	0	0
10.5-18 MPT	524-31-1/-6	1	1	0	1	1	0	1	1	0	0	0	0
400/60-15,5	524-31-5	1	0	1	1	1	0	0	1	1	0	0	0
33x12,5 R15	524-31-7	0	0	0	0	0	1	1	0	0	1	0	0
33x12,5-15	524-31-4	1	1	1	1	1	0	1	1	0	1	0	0
33x15,5-15	524-31-3	1	1	1	1	1	0	1	1	0	1	0	0
33/18 LL-16.1	524-31-9	1	1	1	1	1	0	1	1	1	1	1	0
31x15,5-15	524-31-2	1	0	0	0	0	1	0	0	1	1	0	0

- The switches 1 to 6 are set to the positions  
1 - up, or  
0 - down.
- Refit the multi-function display.

Maintenance as required

**Checking the Air Cleaner System**

The filter cartridge must be serviced when the flow resistance of the filter is highest due to the restriction of the element. This is indicated by the sounding of a horn.

- Stop the engine.
- Raise the dump body (loading platform\*) and secure it against accidental lowering.
- Loosen the hose clamp (1).
- Remove the air filter housing clamping band (2) and turn the air filter housing up.
- Open the air filter cover clips.
- Pull off the housing cover and clean the dust ejection valve (3).
- Pull the air filter cartridge (4) out of the housing by rotating it slightly.

**Cleaning:**

- Blow out the air filter cartridge with compressed air (max. 5 bar) from the inside out.

**Replacement:**

- Install a new air filter cartridge.

Clean the air filter housing with a moist cloth before installation.

The installation of the air filter cartridge is in the reverse order of removal.

\* Option

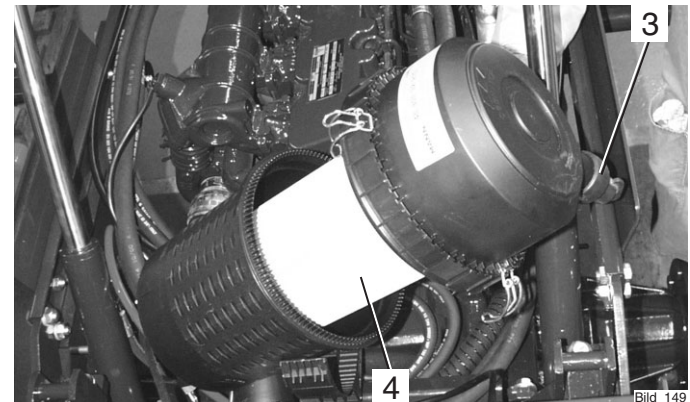
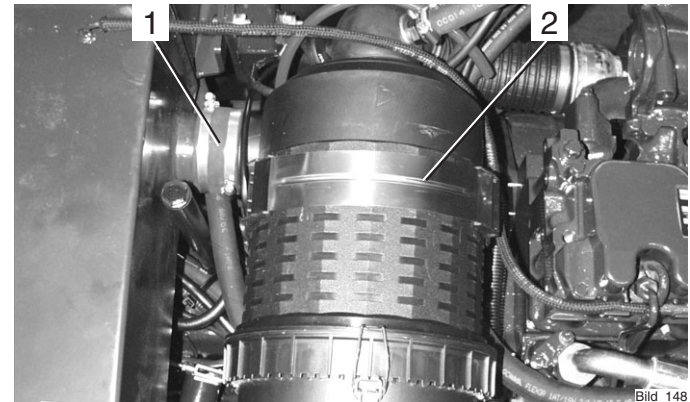

### Maintenance as required

#### Changing the Hydraulic Oil Return Filter for the Variable Pump\*

The hydraulic oil return filter with service indicator is located at the rear right hand side of the tractor below the cabin.



#### **ATTENTION**

*The hydraulic oil return filter must be replaced if the pressure at the service indicator (1) rises to 3 bar pressure when the engine is at idling speed and the implement variable pump is running when equipment (for example spiral-bladed lawn mower) is installed.*

- Relieve any pressure in the hydraulic system by turning the implement off.
- Loosen the hydraulic oil return filter (2) with a filter wrench.



#### **ATTENTION**

*Observe the instructions for handling fuels and lubricants.*

- Clean the mating surface of the filter mount.
- Coat the new seal with oil.

\* Option

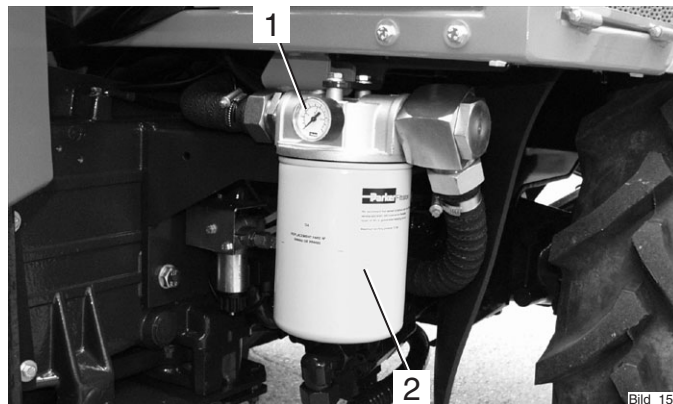

- Install and hand tighten the new oil filter cartridge with a new seal in the filter mount.
- Make a trial run and check for leaks.
- Check the hydraulic oil level.



## Maintenance as required

### Changing the Hydraulic Oil Return Filter for Power Hydraulics\*

The hydraulic oil return filter with service indicator is located at the rear right hand side of the tractor below the cabin.



#### **ATTENTION**

*The hydraulic oil return filter must be replaced if the pressure at the service indicator (1) rises to 3 bar with the installed equipment (eg spiral-bladed lawn mower) at engine idling speed and the power hydraulics on.*

- Relieve any pressure in the hydraulic system by turning the implement off.
- Loosen the hydraulic oil return filter (2) with a filter wrench.



#### **ATTENTION**

*Observe the instructions for handling fuels and lubricants.*

- Clean the mating surface of the filter mount.
- Coat the new seal with oil.

\* Option

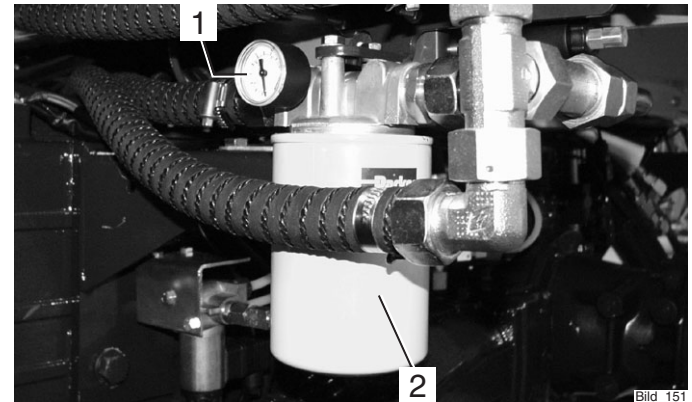

- Install and hand tighten the new oil filter cartridge with a new seal in the filter mount.
- Make a trial run and check for leaks.
- Check the hydraulic oil level.



## Maintenance According to Intervals

### Maintenance Every 125 Service Hours

**ATTENTION**

Carry out the services and inspections only with the engine turned off.

#### Checking the Cooling System

- Inspect the cooling fins and oil cooler for the accumulation of dirt.

#### Cleaning the Cooling System

##### Cleaning with Compressed Air

- Raise the dump body (loading platform\*) and secure it against accidental lowering.
- Blow compressed air through from the engine side to remove any dirt and debris.

##### Cleaning with Cold Cleaner or Water Jet

**ATTENTION**

Maximum spray pressure 60 bar, maximum steam temperature 60 °C

\* Option

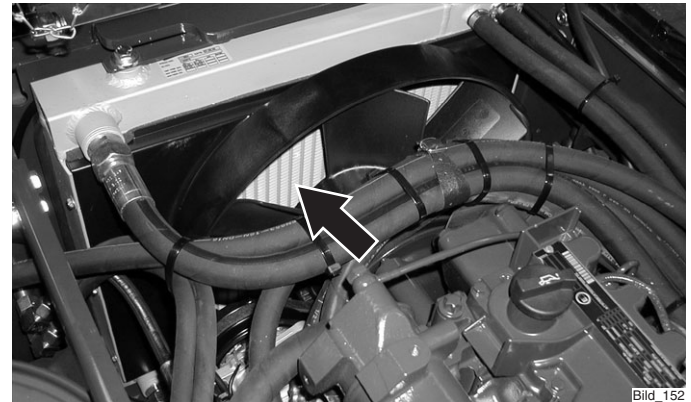

- Raise the dump body (loading platform\*) and secure it against accidental lowering.
- Spray the oil cooler and engine with a cold cleaner and allow it to soak in for 10 minutes.
- Clean the oil cooler and engine with a strong water jet.

**ATTENTION**

Do not aim the water jet directly at delicate parts such as the alternator; cover them if necessary.

- Run the engine warm to prevent the formation of rust.

### Maintenance Every 125 Service Hours

#### Checking the Battery and Cable Connections



#### **CAUTION**

*When working on the electrical equipment, always disconnect the ground lead (1) of the battery.*

- Check the battery acid level and inspect the battery for leaks. Observe the information of the battery manufacturer.
- Remove any corrosion on the terminals.
- Grease the battery terminals with non-acidic battery grease.
- Check cables and cable connections for secure connection and damage.
- Replace any damaged cables and cable connections.

#### Checking the High Pressure Hoses

- Check the high-pressure hoses for cracks, bending and chafing, and for porous surfaces.  
Replace damaged high-pressure hoses immediately.

This work may only be carried out by an authorized workshop.



Bild\_153

## Maintenance Every 125 Service Hours

### Checking the Steering Cylinders and Orbitrol

- Check the steering cylinders and orbitrol for damage and leaks.
- Have damaged or leaky parts replaced by an authorized workshop.

### Checking the Brake Fluid Level for the Foot Brake

- Check the brake fluid level in the reservoir for the foot brake (2). The brake fluid level should be between the markings.
- To fill brake fluid, unscrew the reservoir cap (2) and fill recommended brake fluid as far as the marking.

Filling quantity ..... approx. 0.4 litres (0.105 USGAL.)



#### **ATTENTION**

*Do not mix different kinds of brake fluids.*

### Checking the Clutch\* Brake Fluid Level

- Check the brake fluid level in reservoir for the clutch (1). The brake fluid level should be between the markings.

\* mechanical gearbox only

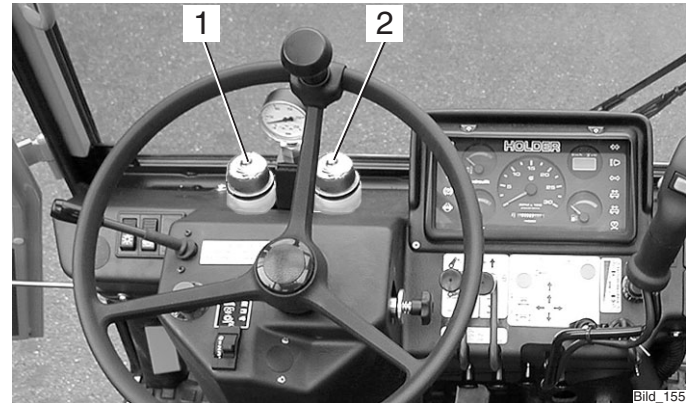

- To fill brake fluid, unscrew the reservoir cap (1) and fill recommended brake fluid as far as the marking.

Filling quantity ..... approx. 0.25 litres (0.066USGAL.)



#### **ATTENTION**

*Do not mix different kinds of brake fluids.*

### Maintenance Every 125 Service Hours

#### Checking the Clutch (if mechanical gearbox is fitted)

- Have the clutch pedal play (1) checked by an authorized workshop.

#### Checking the PTO clutch

Have this work carried out by an authorized workshop.

- Check the linkage rod for slight play. The clevises should not be too tight or have too much play.

#### Checking the Braking System



#### **DANGER**

*Do not operate the tractor with a defective braking system.*

- Carefully apply the parking brake while driving. The tractor should be braked noticeably.



#### **CAUTION**

*When the foot brake pedal (2) is depressed, the tractor is braked strongly.*

- Depress the foot brake pedal (2) while driving slowly. The tractor should brake strongly.



#### **DANGER**

*In case of irregularities with the braking system, stop the tractor immediately and have it checked by an authorized workshop.*

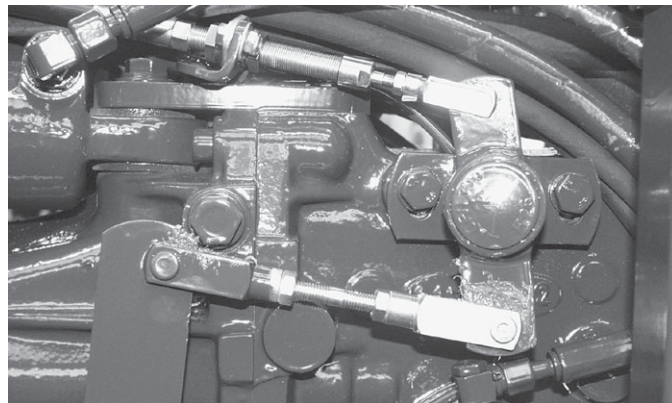
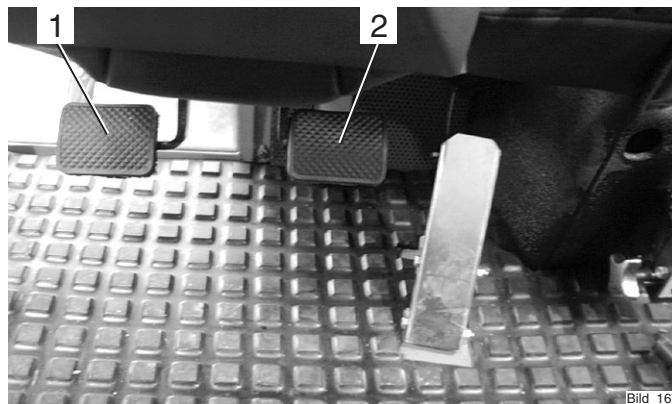

**Tractor Lubrication**

- Lubricate the grease nipples according to the lubrication chart. Only use recommended grease.

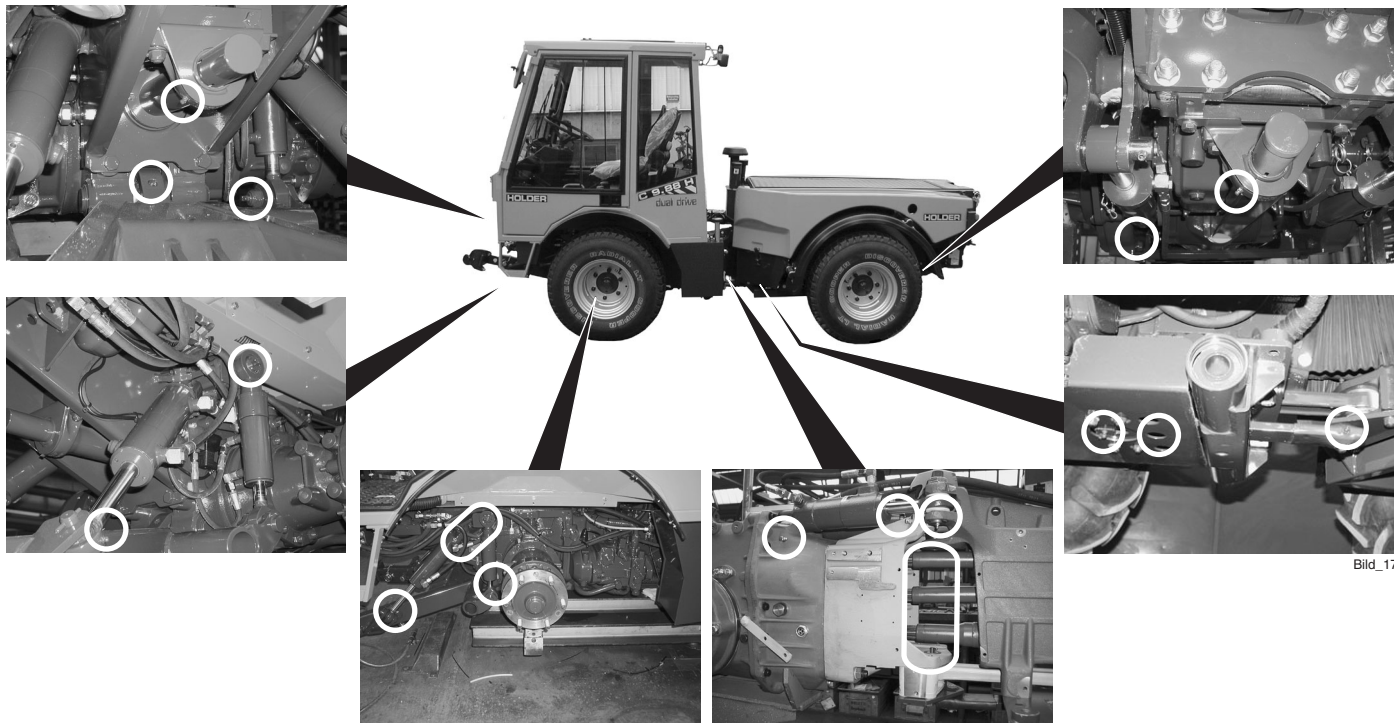

Bild\_173

### Maintenance Every 125 Service Hours

#### Tightening Nuts and Bolts

- Tighten the transmission, axles and engine fasteners.
- Tighten fasteners to the specified torque according to tables in the maintenance data.

#### Tightening the Wheel Nuts

- Tighten all wheel nuts at the front and rear wheels (1 and 2).

Torque ..... 340 Nm

#### Checking the Electrical System



#### **CAUTION**

*When working on the electrical system, always disconnect the ground lead of the battery!*

- Raise the dump body (loading platform\*) and secure against accidental lowering.
- Check cables, plugs and cable ducts for damage and security.
- Have any damaged parts replaced by an authorized workshop.

\* Option



Bild\_171



## Maintenance Every 125 Service Hours

### Cleaning the Upper Fresh Air Filter

- Remove the fastening screws (1).
- Remove the filter cover (2) and filter element.
- Clean the filter element or replace it.



#### **NOTE**

*A charcoal filter\* is available for such applications as spraying insecticides, etc.*

- Refit the filter cover and filter element.

### Cleaning the Lower Fresh Air Filter

- Remove the fastening screws (3).
- Remove the rear panel (4) and take out the filter element upwards.
- Clean the filter element or replace it.
- Re-install the filter element and rear panel.



#### **ATTENTION**

*When a charcoal filter (in item 2) is installed, the lower fresh air filter must be closed airtight.*

\* Option

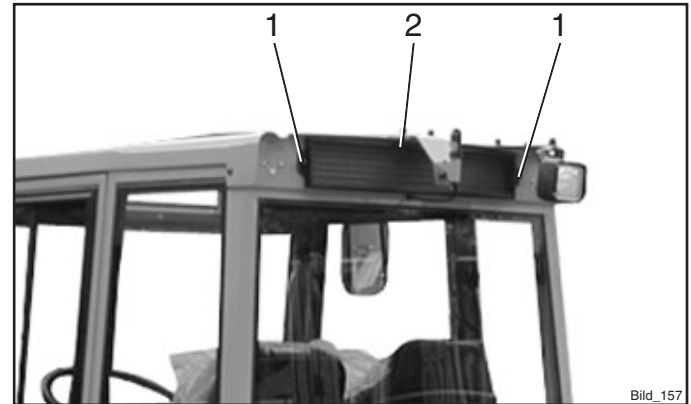

Bild\_157

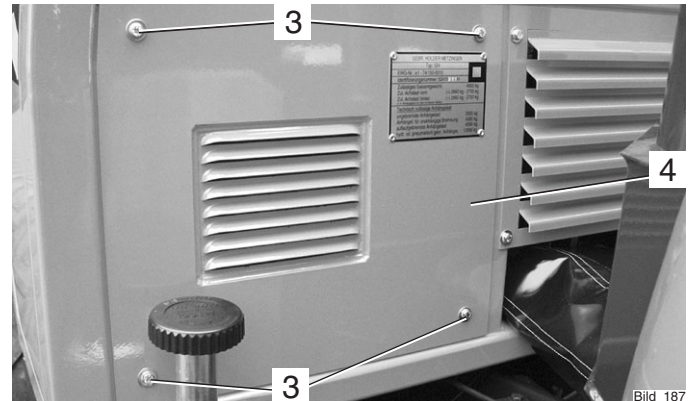

Bild\_187



## Maintenance Every 500 Service Hours

### Changing the Engine Oil

- Run the engine warm to operating temperature.
- Set the heating control to high.
- Place the tractor on level ground and turn off the engine.
- Place a suitable oil pan underneath the engine.



#### **CAUTION**

*Danger of scalding when draining hot engine oil.*

- Unscrew the oil drain plug.
- Allow the oil to run out completely.



#### **ATTENTION**

*Observe the instructions for handling fuels and lubricants.*

- Screw the oil drain plug in again with a new seal and tighten to a torque of 55 Nm.
- Fill new engine oil at the filler neck (1). Only use recommended engine oil.

**Filling quantity ..... 8.75 litres (2.31 USGAL.)**

- Let the engine idle shortly.
- After approx. 1 minute, check the oil level with the dipstick (2).

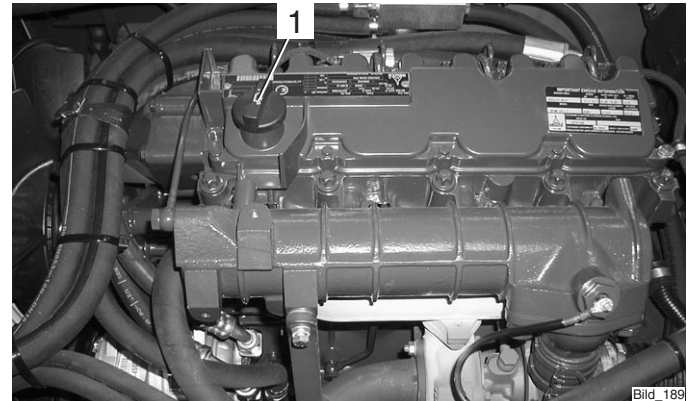

Bild\_189

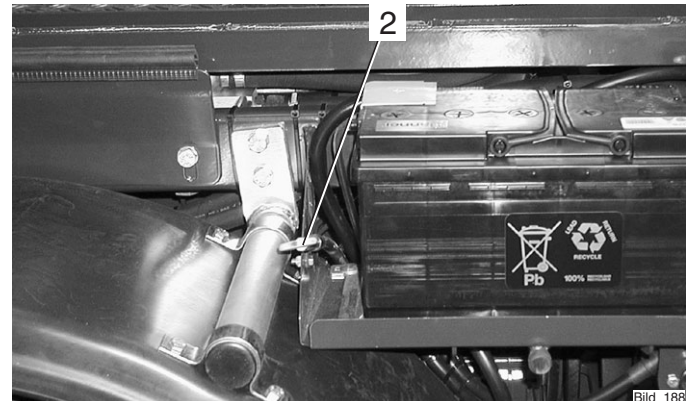

Bild\_188

### Maintenance Every 500 Service Hours

#### Changing the Engine Oil Filter

See the operating manual of the engine manufacturer.

- Drain the engine oil.
- Unscrew the air filter cartridge (1) with a filter wrench.



#### **ATTENTION**

*Observe the instructions on handling fuels and lubricants.*

- Clean the mating surface of the filter mount.
- Screw a new air filter cartridge with a new seal in the filter mount until the seal makes contact.
- Tighten the air filter cartridge half a turn.
- Top up engine oil. Check the oil level.

#### Checking Hose Couplings for Leaks

- Check all hose couplings for leaks; use leakage spray, if necessary. Eliminate any leaks immediately.

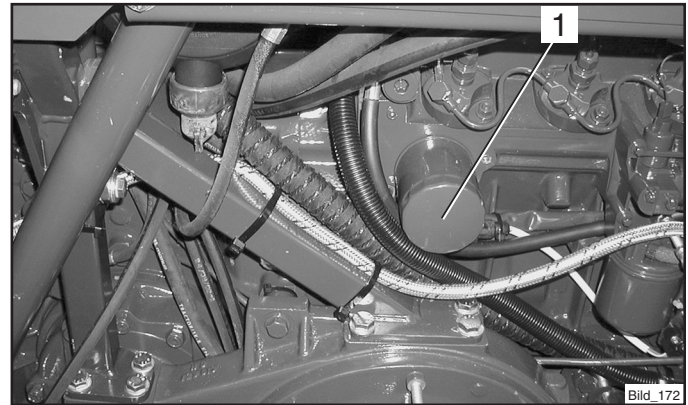

### Changing the Hydraulic Oil Pressure Filter (Drive Hydraulics)

- Remove the air filter housing (1) with a 24mm wrench.



#### **ATTENTION**

*Observe the instructions on handling fuels and lubricants.*

- Clean the mating surface of the filter mount.
- Withdraw the pressure filter from the housing.
- Clean the housing.
- Coat the new seal with oil.
- Insert the new pressure filter in the air filter housing.
- Screw the air filter housing with a new seal in the filter mount.
- Make a trial run and check for leaks.
- Check the hydraulic oil level.



### Maintenance Every 500 Service Hours

#### Changing the Hydraulic Oil Pressure Filter (Implement Hydraulics)

- Relieve any pressure in the hydraulic system by operating the control levers.
- Remove the air filter housing (1) with a 24mm wrench.



#### **ATTENTION**

*Observe the instructions for handling fuels and lubricants.*

- Clean the mating surface of the filter mount.
- Withdraw the pressure filter from the housing.
- Clean the housing.
- Coat the new seal with oil.
- Insert the new pressure filter in the air filter housing.
- Screw the air filter housing with a new seal in the filter mount.
- Make a trial run and check for leaks.
- Check the hydraulic oil level.

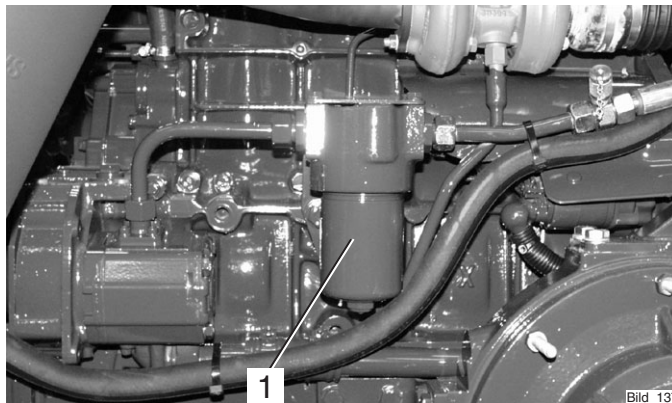

### Checking the Heating System

- Set the heat shut-off valve lever (1) down to the "OFF" position.
  - Run the engine warm.
  - Set the heat shut-off valve lever (1) up to the "ON" position.
- 
- Set the heating blower switch (2) to stage 2. Warm air should flow out of the legroom heating nozzles.

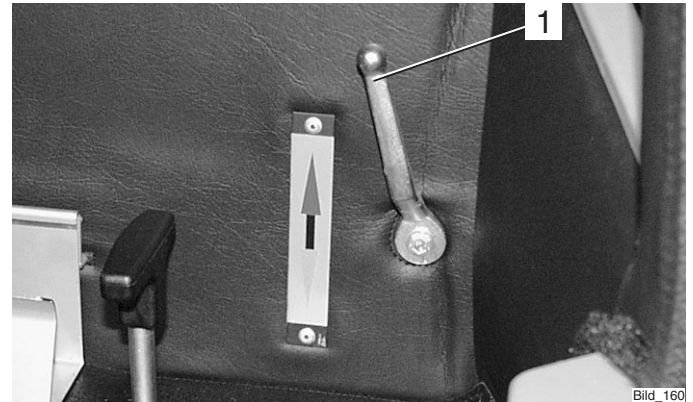





## Maintenance Every 1000 Service Hours

### Checking Valve Clearance

See the operating manual of the engine manufacturer.

### Checking the Battery

**CAUTION**

*For the sake of your safety, observe the following instructions.*

*The battery contains dissolved sulphuric acid, which is poisonous and caustic.*

*When working with battery acid, wear personal protective equipment (protective apron, protective gloves) and eye protectors. If your clothing, skin or eyes have nevertheless come in contact with battery acid, the affected parts must be rinsed at once with water. If the eyes are affected, seek medical aid immediately. Neutralize spilled battery acid immediately.*



*Gases are released when batteries are charged. To prevent an explosion, keep sparks, naked fires away. Rooms, in which batteries are charged or stored, must be ventilated accordingly.*

**NOTE**

*The charging, servicing and care of the battery must always be according to the maintenance instructions of the battery manufacturer.*

## Maintenance Every 1000 Service Hours

### Checking V-belt Tension and Condition

See the operating manual of the engine manufacturer.



#### **CAUTION**

*Adjust V-belt tension only when the engine is shut off.*

- Inspect V-belts for cracks and tears over their entire length.
- Replace damaged V-belts.
- Using thumb pressure, check if the V-belt can not be depressed more than 10 - 15 mm.
- To tighten the V-belt: Loosen the idler pulley mounting screws and push the pulley outwards until the proper V-belt tension is reached.
- Tighten the idler pulley mounting fastening screws.

### Changing the Fuel Filter

See the operating manual of the engine manufacturer.

- Remove the fuel filter cartridge with a filter wrench.



#### **ATTENTION**

*Observe the instructions for handling fuels and lubricants.*

- Clean the mating surface of the filter mount.
- Coat the new seal with oil.
- Install and hand tighten the new filter cartridge with a new seal in the filter mount.



#### **NOTE**

*The fuel system bleeding takes place automatically.*

### Cleaning/Replacing the Fuel Pump Strainer

See the operating manual of the engine manufacturer.

## Maintenance Every 1000 Service Hours

### Lubricating the Cardan Shaft

- Turn the steering wheel right or left until the steering stop is met.



#### **CAUTION**

*Carry out services in the articulated joint area only with the engine shut off.*

- Remove the rubber protector.
- Adjust the top cardan shaft (1) by hand until the grease nipples are easily accessible.
- Grease the top cardan shaft.
- Move centre cardan shaft (2) with starter, until grease nipples are easily accessible.



#### **CAUTION**

*Make sure no-one is standing in the area of the articulated joint when the starter is operated.*

- Grease the centre cardan shaft.
- Adjust the lower cardan shaft (3) by moving the tractor forward or back until grease the nipples are easily accessible.
- Grease the lower cardan shaft.
- Refit the rubber protector at the articulated joint.

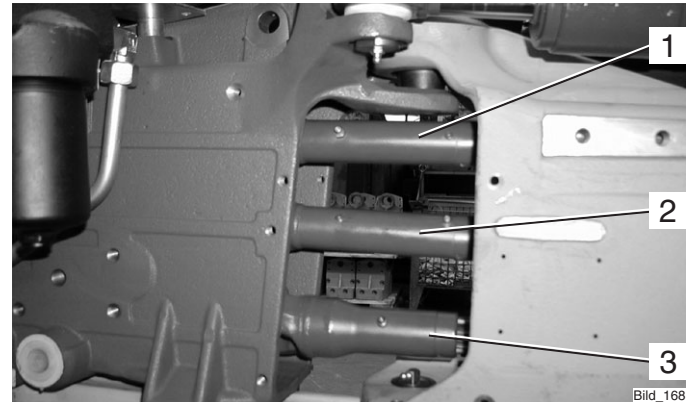



## Maintenance Every 1500 Service Hours

### Change the Front Gearbox Oil (Including Axles)

**NOTE**

*Change the gear oil while still warm.*

- Place the tractor on level ground.
- Unscrew the filler plug (1) at the front gearbox and clean it with Diesel fuel.
- Place a suitable catch pan beneath the gearbox.

**CAUTION**

*Danger of scalding when draining of hot gear oil.*

- Unscrew the oil drain plug (2) at the front gearbox and wash it with Diesel fuel.
- Allow the oil to drain completely.
- Refit the oil drain plug with a new seal, ensuring it is properly seated.

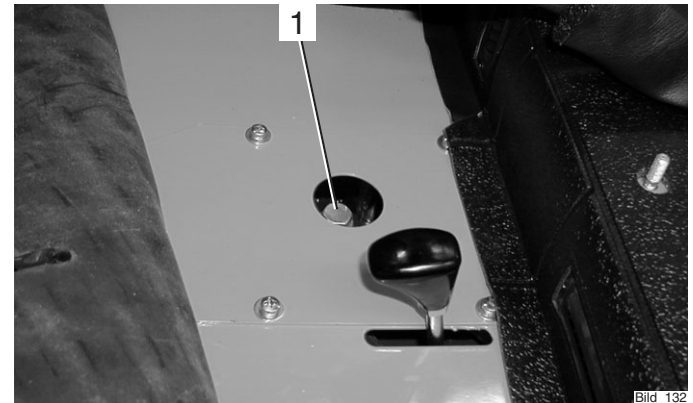

Bild\_132

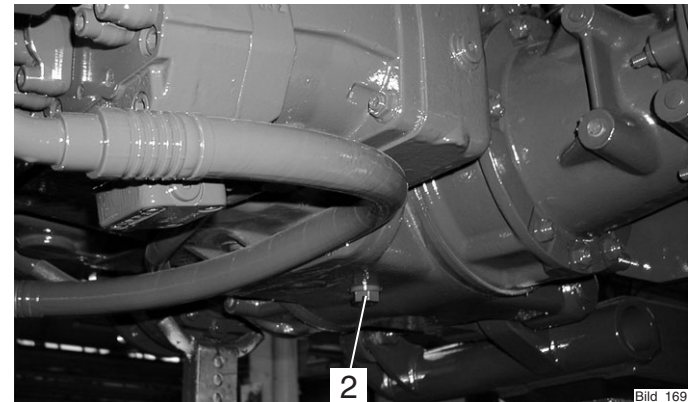

Bild\_169

### Maintenance Every 1500 Service Hours

#### Filling Oil (Hydrostatic Drive Only)

- Unscrew the oil level plug (3).
- Fill recommended gear oil through the filler plug hole until it runs out at the level plug hole.

**Filling quantity ..... approx. 10.9 litres (2.88 USGAL.)**

- Refit the oil level plug with a new seal, ensuring it is properly seated.

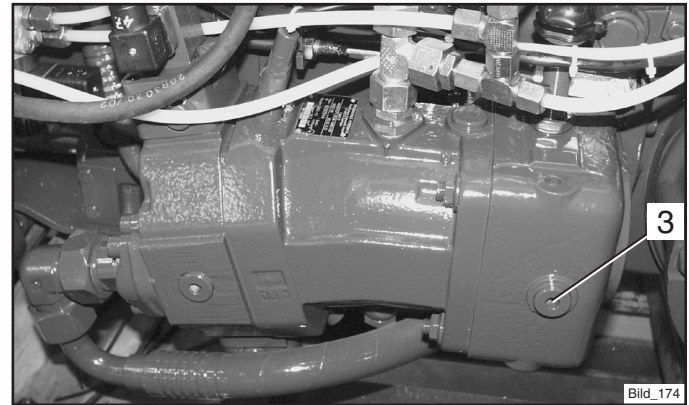

#### Filling Oil (Gearbox Only)

- Fill recommended gear oil through the filler plug hole.

**Filling quantity ..... approx. 10.9 litres (2.88 USGAL.)**

- Check the oil level at the sight glass (4).  
The oil level should be visible through the sight glass.

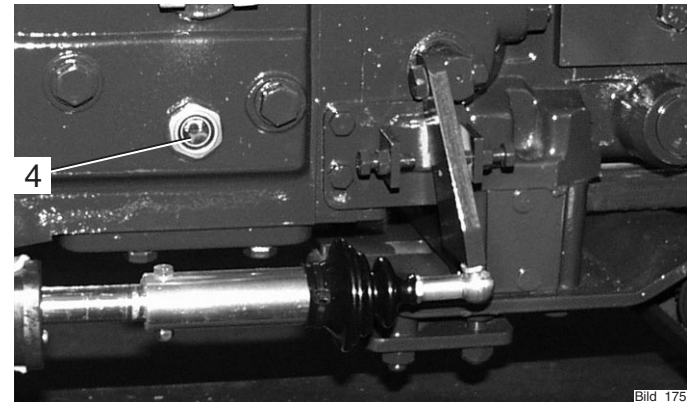

## Maintenance Every 1500 Service Hours

### Changing the Rear Gearbox Oil (Including Offset Axles)



#### **NOTE**

*Change the gear oil only when still warm.*

- Place the tractor on level ground.
- Unscrew the filler plug (1) at the rear gearbox and wash it with Diesel fuel.
- Place a suitable catch pan beneath the gearbox.



#### **CAUTION**

*Danger of scalding when draining hot gear oil.*

- Unscrew the oil drain plug (2) at the rear gearbox and wash it with Diesel fuel.
- Allow the oil to drain completely.

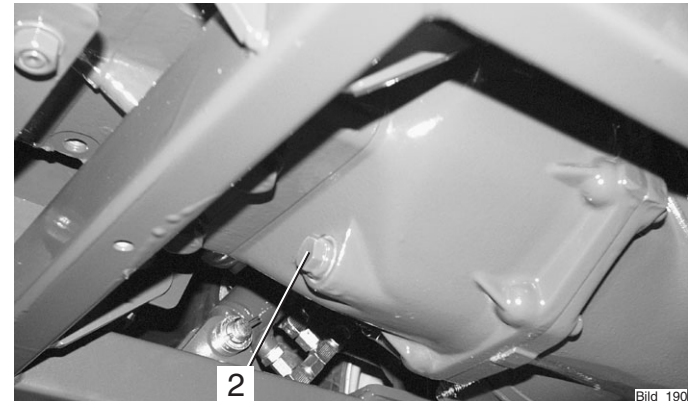
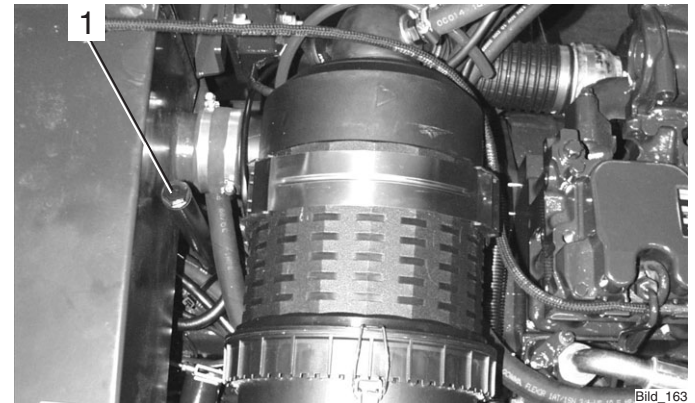

### Maintenance Every 1500 Service Hours

- Refit the oil drain plug with a new seal, ensuring it is properly seated.
- Fill recommended gear oil through the filler plug hole.

**Filling quantity ..... approx. 17.75 litres (4.69 USGAL.)**

- Check the oil level at the sight glass (3).
- The oil level should be visible through the sight glass.
- Then fill another 3 litres (0.79 USGAL.) of gear oil.

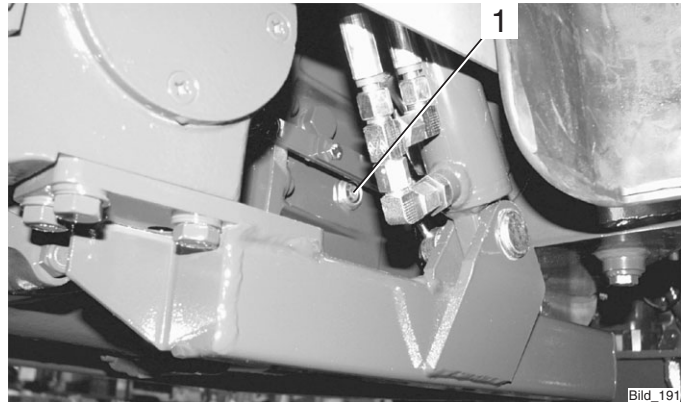



## Maintenance Every 1500 Service Hours

### Changing the Drive Hydraulics Oil



#### **NOTE**

*Change the hydraulic oil while still warm.*

- Place the tractor on level ground.
- Place a suitable oil container beneath the hydraulic oil tank.



#### **CAUTION**

*Danger of scalding when draining hot hydraulic oil.*

- Unscrew the oil drain plug (3).



Drain the oil.

- If required, flush the hydraulic oil tank with clean hydraulic oil.

### Checking or Cleaning the Hydraulic Oil Suction Filter of Drive Hydraulics

- Unscrew the banjo screw (4) and move the hose to the side.
- Remove the filter cover fastening screws (5).
- Withdraw the filter housing with the sieve-star filter.

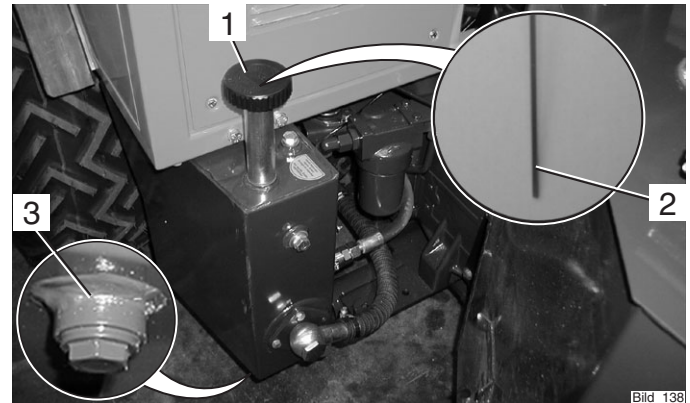

Bild\_138

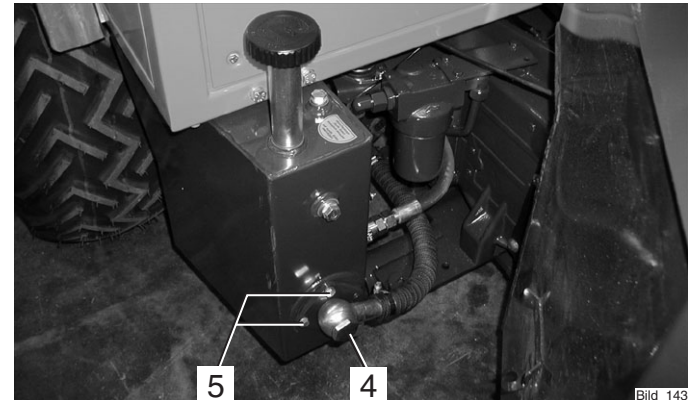

Bild\_143

### Maintenance Every 1500 Service Hours



#### **ATTENTION**

Observe the instructions for handling fuels and lubricants.

#### **Cleaning:**

- Wash the sieve-star filter with clean Diesel fuel.

#### **Replacement:**

- Unscrew the sieve-star filter from the filter housing with a 24mm open-ended wrench.
- Fit a new toroidal sealing ring on the new filter and screw it on to the filter housing.

The installation of the suction filter is carried out in the reverse order of removal.

- Refit the oil drain plug (3) with new sealing ring, ensuring it is properly seated.
- Fill recommended hydraulic oil through the filler neck (1).

#### **Filling quantity ..... approx. 19 litres (5.02 USGAL.)**

- Check the oil level with the oil dipstick (2).
- Refit the filler neck cap.

- Start the engine and make a slow trial drive with the tractor.



#### **NOTE**

The air in the hydraulic system is bled automatically.

- Shut off the engine.
- Check for leaks.
- Recheck the oil level with the oil dipstick (2) and top up hydraulic oil, if necessary .

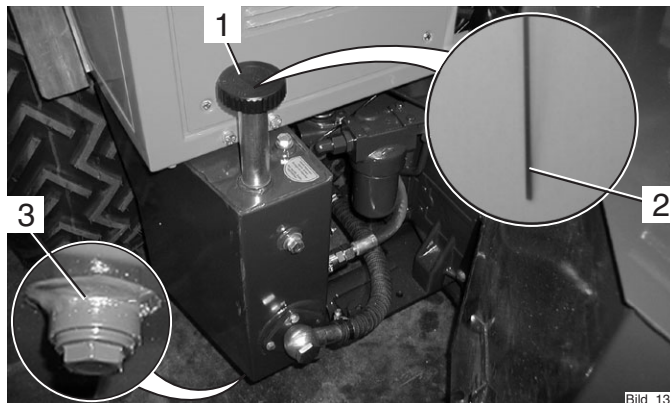

Bild\_138

## Maintenance Every 1500 Service Hours

### Changing the Implement Hydraulics Oil



#### **NOTE**

*Change the hydraulic oil while still warm.*

- Place the tractor on level ground. Raise the loading platform.



#### **CAUTION**

*Secure the dump body (loading platform)\* against accidental lowering.*

- Place a suitable oil container beneath the hydraulic oil tank.
- Relieve any pressure in the hydraulic system by operating the control levers.



#### **CAUTION**

*Danger of scalding when draining hot hydraulic oil.*

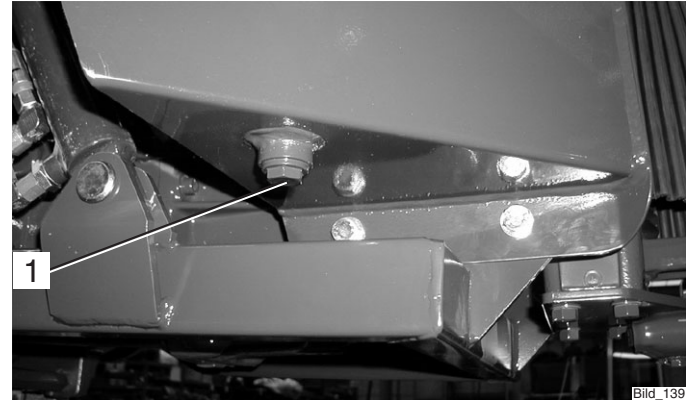

- Unscrew the oil drain plug (1).
- Drain the oil.



Please ensure the oil is disposed of properly.

- If required, flush the hydraulic oil tank with clean hydraulic oil.

### Maintenance Every 1500 Service Hours

#### Checking or Cleaning the Implement Hydraulics Suction Filter

- Remove the mounting pin (4) of the hydraulic cylinder (5).
- Remove the banjo screw (3).
- Remove the filter cover fastening screws (2).
- Withdraw the filter housing with the sieve-star filter.



#### **ATTENTION**

*Observe the instructions for handling fuels and lubricants.*

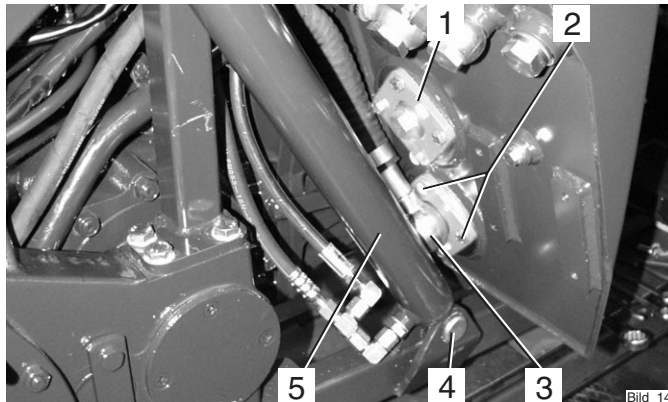

#### Cleaning:

- Wash the sieve-star filter with clean Diesel fuel.

#### Replacement:

- Unscrew the sieve-star filter from the filter housing with a 24mm open-ended wrench.
- Screw the new filter with a new toroidal sealing ring on to an the filter housing.

The installation of the suction filter is carried out in the reverse order of removal.

If an implement variable pump\* or power hydraulic system\* is installed, an additional sieve-star filter is installed in the flange (1). If so, it must also be cleaned or changed as described above.

\* Option

## Maintenance Every 1500 Service Hours

- Refit the oil drain plug with a new seal, ensuring it is properly seated.
- Fill recommended hydraulic oil through the filler neck (6).

Filling quantity ..... approx. 45 litres (11.89 USGAL.)

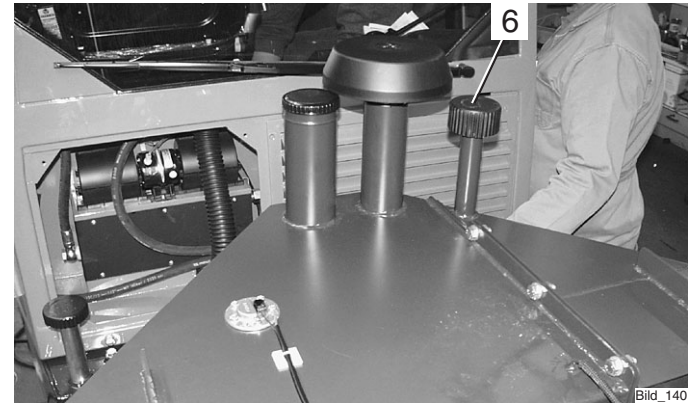

Bild\_140

- Check the oil level at the sight glass (7).
- Refit the filler neck cap.
- Start the engine. Operate the implement hydraulics and steering.



### **NOTE**

*The air in the hydraulic system is bled automatically.*

- Shut off the engine and relieve any pressure in the hydraulic system.
- Check for leaks.
- Check the oil level at the sight glass (7), adding hydraulic oil if required.

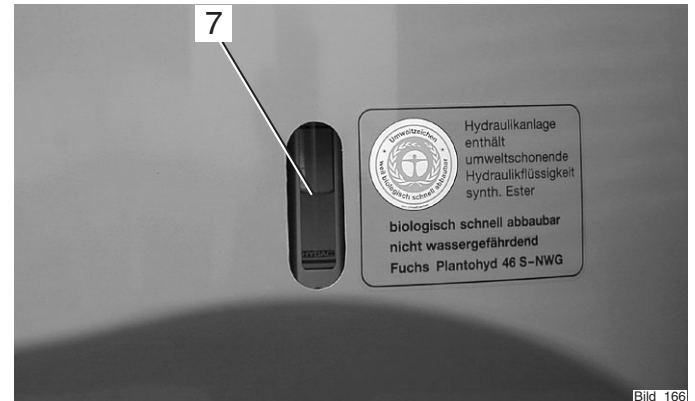

Bild\_166

## **Maintenance Every 1500 Service Hours**

### **Changing the Hydraulic Oil Return Filter for the Implement Variable Pump\***

Carry out the services and inspections as described in the section "Maintenance as Required".

### **Changing the Hydraulic Oil Return Filter for Power Hydraulics\***

Carry out the services and inspections as described in the section "Maintenance as Required".

\* Option

## Maintenance Every 3000 Service Hours



### **NOTE**

*When replacing the toothed belt, also replace the idler pulley.*

### Checking the Injection Nozzles



#### **ATTENTION**

*This work may only be carried out by an authorized workshop.*

- Clean the fuel injector nozzles.
- Check the fuel injector nozzles with a test pressure of 210 +8 bar.

### Changing the Toothed Belt

See the workshop manual of the engine manufacturer.



#### **ATTENTION**

*This work may only be carried out by an authorized workshop.*

- Remove the left-hand cover of the toothed belt drive.
- Check the toothed belt for cracks over its entire length.
- Replace damaged toothed belts.





## Annual Maintenance

### Examination of Implement Hydraulics Oil Samples

**ATTENTION**

*This work may only be carried out by an authorized workshop.*

- Drain a small quantity of hydraulic oil from the hydraulic oil tank for the implement hydraulics.
- Have the oil tested by an authorized workshop/test lab for wear, abrasion chips and contamination.
- If the oil is contaminated, it must be changed. If not, the oil can be used until the maximum of 1500 service hours is reached or for another year, whichever comes first.

## Maintenance Every 2 Years

### Changing the Implement Hydraulics Oil

See "Maintenance Every 1500 Service Hours".

The hydraulic oil must be changed at least every 2 years, even if 1500 service hours were not reached.



## Laying Up

If the tractor is not going to be in service for over 2 months, for example for operational reasons, it must be placed in a well-ventilated, clean and dry room and the following measures must be carried out.

- Clean the tractor thoroughly.
- Check the hydraulic oil levels, topping up oil if necessary
- Cover all blank mechanical components with a thin film of oil or grease.
- Grease the tractor.
- Check the condition and acid density of the battery; cover the battery terminals with non-acidic grease. (Observe the instructions of the battery manufacturer.)
- Remove the battery and store in a frost-free, dry room.

## Engine Preservation

- Clean the engine.
- Run the engine warm.
- Drain the engine oil and refill with anti-corrosion oil.
- Drain some fuel and refill the fuel tank with a mix of 90 % Diesel fuel and 10 % anti-corrosion oil.
- Run the engine for 10 minutes.
- Switch off the engine.

- Turn the engine over a few times by hand.
- Block up the intake opening and exhaust outlet.



### **ATTENTION**

*The tractor must be blocked up so that all the wheels are off the ground to prevent a permanent deformation of the tires.*



### **NOTE**

*Do not use plastic foil to cover the tractor as this enhances the formation and collection of condensate water.*

## Putting the Tractor Back in Service after a Lay-up

If the tractor was taken out of service for over six months, it must be inspected carefully before being put back in service. The inspection should, similar to the safety inspection, also cover all safety points of the tractor.

- Clean the tractor thoroughly.
- Lubricate the tractor.
- Check the condition and acid density of the battery, recharging it if necessary.

### Laying Up

#### Removing Engine Preservation

- Unblock the intake opening and exhaust outlet.
- Drain the anti-corrosion oil and rinse the oil sump with engine oil.



#### **ATTENTION**

Observe the instructions for handling fuels and lubricants.

See the section "Changing the Engine Oil" on how to proceed further.

- Check the hydraulic oil for condensate water, changing the oil if necessary.
- Perform the services and inspections as for before taking into service.
- Refill the fuel tank.
- Change the brake fluid.
- Take the tractor in operation.

When taking into the tractor into service, particularly check:

- Gearboxes and axles for leaks.
- Drive hydraulics, gearshift, steering.
- Brake (service brake, parking brake)
- Implement hydraulics, functions and work movements.

If the tractor is to be laid up for a longer period, please contact your HOLDER Service for further measures.

## Recommended Fuels and Lubricants

### Recommended Hydraulic and Gear Oils

Manufacturer	Recommended Hydraulic Oil HE Oils (Hydr. Ester)	Recommended Gear Oil for Gearbox und Hydrostatic Transmission Utto / Stou
ISO Viscosity Class HLP (HM) HV	VG 46	
AGIP	Agip Arnica S 46	Agip Rotra JDF
ARAL	Vitam EHF 46	Aral Fluid HGS 10W30
AVIA	Syntofluid 46	-----
BECHEM	Hydrostar HEP 46	-----
BP	Biohyd SE 46 – S	BP Hydraulic TF - JD
BAYWA	Plantosyn 3268 ECO	-----
BUCHER	Motorex Biosynt 3268	Farmer 304 JD-M20C
DEA	Econa E 46	-----
ESSO	Univis HE – ES 46	Uniform 15W - 40
ELF	Hydrelf Bio 46	-----
Total	Total Biohydran TMP	Total Multiagri Super 10W-30
FUCHS	Plantohyd 46 S-NWG	-----
OEST	Bio Synthetik HYD 46	-----
SHELL	Naturelle HF – E 46	Shell Harvella T 10W-30
VALVOLINE	Valvoline Ultraplant	-----

## Recommended Fuels and Lubricants

### Recommended Engine Oils and Lubricants

The following oil brands conform to US Military Specification MIL-L-2104C or to API quality CD/SF and ACEA.

<b>Manufacturer</b>	<b>Recommended Lubricating Oil</b>	<b>SAE Class</b>	<b>Recommended Lubricant Penetration Ratio 260 - 290</b>
AGIP	Agip Sigma Ultra TFE	10W-40	Agip GR MU 2
AGIP	Autol Valve Ultra FE	10W-40	
ARAL GmbH	Aral Mega Turboral	10W-40	Multi-purpose grease Long-service grease H
ARAL GmbH	Aral Super Turboral	5W-30	
BAYWA	BayWa Super Truck 1040 MC	10W-40	Baywa multi-purpose grease 2 Special grease FLM
BAYWA	BayWa Turbo 4000	10W-40	
CASTROL GmbH	Castrol SYNTRUCK	5W-40	Castrol LM
CASTROL GmbH	Castrol DYNAMAX	7,5W-40	
CHEVRON	Chevron Delo 400 Synthic	5W-40	
ESSO	Essolube XTS 501	10W-40	Esso Beacon 2 multi-purpose grease
FINA	Fina Kappa First	5W-30	Fina Marson L2 Fina Marson EPL 2
FINA	Fina Kappa Ultra	10W-40	
FUCHS DEA	Dea Cronos Synth	5W-40	Glissando 20 Glissando 283 EP 2 Renolit LZR 2
FUCHS DEA	Dea Cronos Premium LD	10W-40	
FUCHS DEA	Fuchs Titan Cargo MC	10W-40	
FUCHS DEA	Deutz Oil TLL 10W- 40MB	10W-40	
FUCHS DEA	Dea Cronos Premium FX	10W-40	
FUCHS DEA	Fuchs Titan Unic Plus MC	10W-40	

## Recommended Fuels and Lubricants

## Recommended Engine Oils and Lubricants continued

Manufacturer	Recommended Oil	SAE Class	Lubricants Penetration Ratio 260 - 290
MOBIL OEL	Mobil Delvac 1 SHC	5W-40	Mobilgrease MB 2
MOBIL OEL	Mobil Delvac 1	5W-40	
MOBIL OEL	Mobil Delvac XHP Extra	10W-40	
BP OIL International	BP Vanellus HT Extra	10W-40	BP Energrease LS 2 BP multi-purpose grease L2
Shell International	Shell Myrina TX/ Shell Rimula Ultra	5W-40	Retinax EP2
Shell International	Shell Myria TX/ Shell Rimula Ultra	10W-30	
TOTAL	Total Rubia TIR 8600	10W-40	
Wintershall	TFG	10W-40	

**Brake Fluid**

N-DOT 3, DOT 4

**DANGER***Do not use mineral oil.***Fuels**

Observe the specifications of the engine manufacturer.

**NOTE***The use of bio diesel fuel is only allowed after a conversion of the engine by an authorized workshop.*

## Maintenance data

Filling Quantities	C 9700 C 9.72	C 9700/9800 H C 9.72/83 H C 9.78/88 H
Engine oil Including filter 0.5 litres (0.132 USGAL.) Including heating system 1.5 litres (0.396 USGAL.)	12.5 litres (3.3 USGAL.)	12.5 litres (3.3 USGAL.)
Front gearbox with axles, gear oil	10.9 litres (2.88 USGAL.)	---
Front hydrostatic drive with axles, gear oil Initial filling	--- ---	10.9 litres (2.88 USGAL.) 12.7 litres (3.35 USGAL.)
Rear gearbox with axles, gear oil	17.75 litres (4.69 USGAL.)	17.75 litres (4.69 USGAL.)
Implement hydraulics, hydraulic oil*	approx. 45 - 50 litres (11.89 - 13.21 USGAL.)	approx. 45 - 50 litres (11.89 - 13.21 USGAL.)
Hydraulic oil tank for drive, hydraulic oil* Initial filling	--- ---	19 litres (5.02 USGAL.) 22 litres (5.81 USGAL.)
Brake fluid for hydr. clutch	0.25 litres (0.066 USGAL.)	---
Brake fluid for hydr. foot brake	0.4 litres (0.105 USGAL.)	0.4 litres (0.105 USGAL.)
Fuel tank, Diesel fuel	86 litres (22.7 USGAL.)	86 litres (22.7 USGAL.)



**\* NOTE:**

*In order to ensure the biological degradability of the hydraulic oil, all implements connected to the tractor hydraulic system must also be*

*operated with HE oil. Residual quantities of mineral oils reduce the biological degradability. They do not influence operation.*



Tightening Torques

Hexagon Screws and Studs	M 8	M 10	M 12	M 14	M 16
Screw quality 8.8	25 Nm	49 Nm	86 Nm	135 Nm	210 Nm
Screw quality 10.9	35 Nm	69 Nm	120 Nm	190 Nm	295 Nm

Gearbox, Axles, Wheels	Tightening Torque	Engine	Torque
Hexagon screws M 10 (servostat to steering support)	40 Nm	Idler/drive belt	45 Nm
Tension screws for hydraulic control valves	25 Nm	Cylinder head cover	9 ± 1 Nm
Axle housing to gearbox	86 Nm	Rocking lever adjustment screw	20 ± 2 Nm
Axle housing cover M 10 (planetary gears)	69 Nm	Suction pipe (TORX)	21 Nm
Pendulum bearing M 12	86 Nm	Exhaust pipe (TORX)	40 Nm
Pendulum limit stop M 16	210 Nm	Oil drain plug	55 ± 5 Nm
Hitch bar for hitch coupling M 14	135 Nm	Injection valve clamp (TORX)	21 Nm
Wheel nuts (incl. wheel hub spacers)	340 Nm	Plugs and union nuts for heating hoses	65 ± 5 Nm

## Maintenance data

### List of Replacement Parts

Description	Order No.
Sealing ring for oil drain plug	010 395
Engine oil filter	797 135
Valve cover seal	787 357
Air filter cartridge	029 760
KHD fan V-belt	784 992
Fuel filter	782 971
Hydraulic suction filter (implement hydraulic system)	029 541
O-ring 64x3	014 696 (2 items)
Hydraulic suction filter (drive hydraulic system)	029 540
O-ring 64x3	014 696 (2 items)
Hydraulic pressure filter (implement and drive hydraulic system)	132 897 (1 item each)
O-ring for hydraulic pressure filter	028 109
Toothed belt repair kit	786 262
Replacement cartridge for service hydraulics return line filter	029 088
Replacement cartridge for implement variable pump return line filter	143 991

## Bulbs 12 V

Lights	Rating	Lights	Rating
Headlights H4	60/55 W	Hazard warning light switch	2 W
Turn signal light. front	21 W	Engine temperature gauge light	1.2 W
Turn signal light. rear	21 W	Fuel gauge light	1.2 W
Tail light	10 W	Indicator lights	1.2 W
License plate light	5 W	Clearance lights	5 W
Stop light	21 W	Interior light	5 W
Back-up light	21 W	Rotating beacon	45 W
Tachometer for engine and PTO rpm	1.2 W	Multi-function instrument light DIN 72601/W5/12 V	1.2 / 2.0 / 3.0 W
Speed and PTO shaft indicator	1.2 W		

## Maintenance data

Technical Data of Engine	C 9700/9.72	C 9800/9.83H
	C 9700/9.72H	
Manufacturer	Deutz AG	Deutz AG
Type	BF4M1011 53,5 KW	BF4M1011F 61 KW
Design	In-line vertical engine	In-line vertical engine
Mode of operation	4-stroke Diesel	4-stroke Diesel
Cooling	Oil cooling	Oil cooling
Injection system	Direct fuel injection	Direct fuel injection
Number of cylinders	4	4
Cylinder bore	Ø 91	Ø 91
Stroke	112	112
Cylinder capacity	2914	2914
Compression ratio	18	18
Compression pressure	22-27 bar	22-27 bar
Charging pressure	1.25bar	1.25bar
Valve tolerance (cold engine)	Intake valve 0.3 mm Exhaust valve 0.5 mm	Intake valve 0.3 mm Exhaust valve 0.5 mm
Fuel consumption	223g/KW-h at 1500-1750 rpm	222g/KW-h at 1750-1850 rpm
Air filter	Mann and Hummel dry air filter with acoustic alert	Mann and Hummel dry air filter with acoustic alert
Lubrication system	Forced-feed lubrication	Forced-feed lubrication
Lubrication oil consumption	Maximum 0.5% of fuel consumption	Maximum 0.5% of fuel consumption
Oil filter	Changeable cartridge in main flow	Changeable cartridge in main flow
Oil pressure at n=900 rpm	2,0 bar	2.0 bar
Rated speed	2500 rpm	2600 rpm
Maximum idling speed	2600 rpm	2750 rpm
Minimum idling speed	900 rpm	900 rpm
Maximum torque	235 Nm at 1750 - 1850 rpm	255 Nm at 1750 - 1850 rpm
Power acc. to ICE.24/89/ 491/EWG at n=2800 rpm	53.5 KW (72 HP (DIN))	61 KW (83 HP (DIN))

Engine Specifications	C 9.78H	C 9.88H
Manufacturer	Deutz AG	Deutz AG
Type	BF4M2011 57 KW	BF4M2011 65 KW
Design	In-line vertical engine	In-line vertical engine
Mode of operation	4-stroke Diesel	4-stroke Diesel
Cooling	Oil cooling	Oil cooling
Injection system	Direct fuel injection	Direct fuel injection
Number of cylinders	4	4
Cylinder bore	Ø 94	Ø 94
Stroke	112	112
Cylinder capacity	3108	3108
Compression ratio	17.5	17.5
Compression pressure	-----	-----
Charging pressure	0.9 bar	1.15 bar
Valve tolerance (cold engine)	Intake valve 0.3 mm Exhaust valve 0.5 mm	Intake valve 0.3 mm Exhaust valve 0.5 mm
Fuel consumption	216 g/KW-h at 1750-1850 rpm	216 g/KW-h at 1550-1650 rpm
Air filter	Mann and Hummel dry air filter with acoustic alert	Mann and Hummel dry air filter with acoustic alert
Lubrication system	Forced-feed lubrication	Forced-feed lubrication
Lubrication oil consumption	Maximum 0.5% of fuel consumption	Maximum 0.5% of fuel consumption
Oil filter	Changeable cartridge in main flow	Changeable cartridge in main flow
Oil pressure at n=900 rpm	2.0 – 2.5 bar	2.0 – 2.5 bar
Rated speed	2500 rpm	2800 rpm
Maximum idling speed	2750 rpm	3050 rpm
Minimum idling speed	900 rpm	900 rpm
Maximum torque	246 Nm at 1550 - 1650 rpm	266 Nm at 1550 - 1650 rpm
Power acc. to ICE.24/89/ 491/EWG at n=2800 rpm	57 KW (78 HP (DIN))	65 KW (88 HP (DIN))

## Maintenance data

### Fuel System

	all vehicles
Fuel injection pump	BOSCH individual withdrawable element-type calibrated pump
Governor	Governor integrated in front cover
Injection nozzle	5-hole nozzle
Injection pressure	210 bar + 8 bar
Start of fuel injection	4°+/-1° BTDC for 1011 6°+/-1° BTDC for 2011
<b>Drive pump</b>	Hydrostatic drive Axial piston pump, Type 11 VG50 EP Rated pressure 300 bar, Maximum pressure 350 bar A4 VG40 EP Rated pressure 380 bar Maximum pressure 430 bar
<b>Drive motor</b>	Axial piston motor /Type AG KM 55

**Alphabetical Index**

	Page		Page
<b>A</b>			
Accessories .....	48	Air Conditioning .....	129
Activating Functions (Operation) .....	102	Annual Maintenance .....	199
Additional Information for Implements .....	86	Approved Applications .....	5
Adjusting Catch Hook and Catch Hook Bar .....	90	Attaching Implements .....	89
Adjusting the Backrest .....	55	<b>B</b>	
Adjusting the Backrest Tilt .....	57	Ballast Weights .....	84
Adjusting the Driver's Seat .....	55	Battery .....	14
Adjusting the Driver's Weight .....	56	Battery Acid .....	13
Adjusting the Horizontal Suspension .....	56	Bearing Load .....	136
Adjusting the Inch Knob .....	69	Before Starting to Drive .....	63
Adjusting the Length of the Catch Hook Bar .....	90	Brake Fluid .....	205
Adjusting the Lumbar Padding .....	55	Braking .....	77
Adjusting the Passenger Seat .....	57	Bulbs 12 V .....	209
Adjusting the Seat Horizontally .....	56, 57	<b>C</b>	
Adjusting the Speedometer .....	141, 163	Change the Front Gearbox Oil (Including Axles) .....	187
Adjusting the Steering Wheel .....	54	Changing the Direction of Travel .....	70, 75
Adjusting the Track Width .....	82	Changing the Drive Hydraulics Oil .....	191
Adjusting the Upper Link Mount .....	91	Changing the Engine Oil .....	177
Adjusting the Weight .....	57		
Air Conditioner .....	129		

**Index**

	Page		Page
Changing the Engine Oil Filter .....	178	Suction Filter .....	194
Changing the Fuel Filter .....	184	Checking the Air Cleaner System .....	165
Changing the Hydraulic Oil Pressure Filter (Drive Hydraulics) .....	179	Checking the Battery .....	183
Changing the Hydraulic Oil Pressure Filter (Implement Hydraulics) .....	180	Checking the Battery and Cable Connections .....	170
Changing the Hydraulic Oil Return Filter for Power Hydraulics .....	167, 196	Checking the Brake Fluid Level .....	54
Changing the Hydraulic Oil Return Filter for the Implement Variable Pump .....	196	Checking the Brake Fluid Level for the Foot Brake .....	171
Changing the Hydraulic Oil Return Filter for the Variable Pump .....	166	Checking the Braking System .....	172
Changing the Implement Hydraulics Oil .....	193, 199	Checking the Clutch (if mechanical gearbox is fitted) .....	172
Changing the Rear Gearbox Oil (Including Offset Axles) .....	189	Checking the Clutch Brake Fluid Level .....	171
Changing the Toothed Belt .....	197	Checking the Cooling System .....	169
Check the Engine for Leaks .....	161	Checking the Drive Hydraulics Oil Level .....	52
Checking Engine Oil Level .....	50	Checking the Electrical System .....	174
Checking Hose Couplings for Leaks .....	178	Checking the Heating System .....	181
Checking or Cleaning the Hydraulic Oil Suction Filter of Drive Hydraulics .....	191	Checking the High Pressure Hoses .....	170
Checking or Cleaning the Implement Hydraulics		Checking the Implement Hydraulics Oil Level .....	52
		Checking the Injection Nozzles .....	197
		Checking the Lights and Rear View Mirror .....	58
		Checking the PTO clutch .....	172
		Checking the Steering Cylinders and Orbitrol .....	171
		Checking the Trailer Hitch (Optional), if required .....	51
		Checking Tire Inflation Pressure .....	51



	Page		Page
Checking V-belt Tension and Condition .....	184	Drive Range Pre-selection Lever between Seats .....	37
Checking Valve Clearance .....	183	Driver's license .....	7
Cleaning the Cooling System .....	169	Driver's license classes (Germany only) .....	7
Cleaning the Lower Fresh Air Filter .....	175	Driver's Station .....	30
Cleaning the Upper Fresh Air Filter .....	175	Driving .....	64
Cleaning with Cold Cleaner or Water Jet .....	169	Driving on Slopes .....	79
Cleaning with Compressed Air .....	169	Driving Safety Rules .....	63
Cleaning/Replacing the Fuel Pump Strainer .....	184	Driving with Hydrostatic Drive, Digital Electronics and Dual Drive .....	71
Connecting Equipment to Power Socket .....	126	Driving with the Mechanical Gearbox .....	73
Control Lever Functions .....	95	Driving with Trailers .....	137
Controls for Mechanical Gearbox .....	40	<b>E</b>	
Controls in Cabin at Rear .....	42	Emissions .....	13
Controls on Cabin Console at Front Left .....	41	Engaging the Differential Lock .....	76
Controls on Cabin Console at Front Right .....	41	Engaging the Front PTO .....	104
Coupling Hydraulic Lines .....	92	Engaging the Parking Brake .....	78
<b>D</b>		Engaging the Rear PTO .....	105
Date of Issue and Manual Version .....	2	Engine Oil for Winter Operation .....	84
Description .....	28	Engine Preservation .....	201
Development .....	1	Engine Specifications .....	21, 211
Disengaging the Differential Lock .....	76	Examination of Implement Hydraulics Oil Samples .....	199
Disengaging the Parking Brake .....	78		

**Index**

	Page		Page
Exhaust Gas Identification .....	27	Fuse for Air Conditioning .....	131
Exhaust Gases .....	13	Fuses .....	130
Explanations of Terminology .....	2	Fuses for the Cabin .....	131
<b>F</b>		Fuses for the Tractor .....	130
Filling Fuel .....	53	<b>G</b>	
Filling Oil (Gearbox Only) .....	188	Gear Oil, Engine Oil, Diesel Fuel .....	12
Filling Oil (Hydrostatic Drive Only) .....	188	General Notes on Safety .....	11
Filling Quantities .....	206	General Notes on Service .....	1
Filling Washing Water .....	58	General Remarks on Maintenance .....	149
Foot Pedals .....	36	<b>H</b>	
Foreword .....	1	Handling fuels and lubricants .....	151
Front Implement .....	87	Heat .....	14
Front Left View .....	28	Heater .....	38
Front Lift 1 - Lifting/Lowering .....	99	Heater and ventilation .....	127
Front Lift 2 - Shifting Left/Right .....	100	Heating .....	127
Front Lift 3 - Lateral Tilt .....	101	How to Value the Tractor? .....	149
Front PTO Selector .....	38	Hydraulic Carrier Control (Power Lifter) .....	36
Front Windshield Wiper/Washer .....	120	Hydraulic Oil, Brake Fluid .....	13
Fuel System .....	212	Hydraulic Oil Flow for Stationary Operation .....	81
Fuels .....	205	Hydraulic System .....	84
Functions of Lock-out Knob .....	95		

	Page		Page
<b>I</b>			
Identification Plates .....	43	List of Replacement Parts .....	208
Implement and Engine Controls (Details) .....	32	Location of Plates and Labels .....	43
Indicators, Adjustments .....	141	Lubricating the Cardan Shaft .....	185
Installing the Cardan Shafts .....	93	<b>M</b>	
Instructions before Starting .....	59	Maintenance According to Intervals .....	169
Instructions before Starting the Engine .....	59	Maintenance after the First 50 Operating Hours .....	161
Instructions for Loading .....	139	Maintenance as Required .....	163
Instructions for Operation .....	7	Maintenance during the	
Instructions for the Tractor .....	5	First Period of Operation .....	157, 161
Instructions for Towing .....	140	Maintenance Every 1000 Service Hours .....	183
Instructions for Transport .....	139	Maintenance Every 125 Service Hours .....	169
Interior Light .....	125	Maintenance Every 1500 Service Hours .....	187
<b>J</b>			
Jack Lifting Points .....	154	Maintenance Every 2 Years .....	199
Jacking Up .....	154	Maintenance Every 3000 Service Hours .....	197
<b>L</b>			
Laying Up .....	201	Maintenance Every 500 Service Hours .....	177
Leaving the Tractor .....	133, 134	Maintenance Schedule .....	157
Legend for Multi-function Display .....	39	Model Variants .....	15
Lights .....	121	Mounting Instructions for License Plate .....	44
		Multi-function Lever .....	33
		Multi-function Lever (Variant 1) .....	33, 96
		Multi-function Lever (Variant 2) .....	34, 98

**Index**

	Page		Page
Multi-function Lever (Variant 3) .....	35	Operating the Power Hydraulics ( 75 L Fixed Flow) .....	110
Multi-function Lever (Variant 4) .....	102	Operating the Priority Flow Valve I .....	115
Multi-function Lever (Variant 4) .....	35	Operating the PTO .....	103
Multi-function Lever Functions .....	96	Operating the Radio .....	126
<b>N</b>		Operating the roof hatch .....	119
Noise Level .....	27	Operating the Service Brake .....	77
Note on Disposal of Tractor .....	6	Operating the Trailer Coupling, Attaching Trailers .....	136
<b>O</b>		Operation .....	63
Opening the roof hatch .....	119	Operation in Winter .....	84
Operating controls .....	30	Operation with Carrier .....	107
Operating Controls Behind the Seat .....	37	Other Activities .....	119
Operating Implements .....	94	Overview of Options and Variants .....	45
Operating priority flow valve II .....	117	<b>P</b>	
Operating the Air Conditioner .....	129	Parking .....	134
Operating the Driver's Cab .....	119	Possible Implements .....	85
Operating the Horn .....	123	Power Socket .....	126
Operating the Hydraulic Carrier (Power Lifter) .....	106	Preheating of Oil .....	84
Operating the Hydraulic Control Levers .....	94	Problems, Cause, Remedy .....	143
Operating the Hydraulic Dumper .....	112	Problems in Electronic and Hydraulic Drive System ....	143
Operating the Implements .....	85	Problems in Engine and Exhaust Gas Turbocharger ....	143
Operating the Inch Pedal .....	70	Problems in the Hydraulic System and Steering .....	147
		Putting on Snow Chains .....	84

	Page
Putting the Tractor Back in Service after a Lay-up .....	201
<b>Q</b>	
Qualification of the Service Personnel .....	149
<b>R</b>	
Radio and Loudspeaker .....	126
Rear Implement or Front/Rear Combinations .....	87
Rear Right View .....	29
Rear Wiper/Washer .....	120
Recommended Engine Oils and Lubricants .....	204
Recommended Engine Oils and Lubricants continued .....	205
Recommended Fuels and Lubricants .....	203
Recommended Hydraulic and Gear Oils .....	203
Regular Maintenance .....	158
Removing Engine Preservation .....	202
Removing Implements .....	93
Removing the roof hatch .....	119
Residual Hazards and Risks .....	6
Right and Left Turn Signal .....	123
Road Travel with Carrier .....	107

**S**

Safety .....	11
Safety Instructions for Handling Fuels and Oils .....	12
Safety Instructions for Handling Implements .....	85
Safety Notes for Later Installations .....	11
Safety Notes for Maintenance .....	151
Securing the Frame (Loading Platform) .....	155
Selecting Road Speed (Transport Speed) .....	67
Service .....	149, 150
Setting the Working Speed of Programs 3 and 4 .....	67
Site of Operation .....	5
Special Operating Instructions .....	81
Starting the Engine .....	59, 60
Stationary Operation .....	81
Steering .....	77
Stopping the Tractor .....	133

**T**

Table of Contents .....	3
Table of Dimensions .....	17
Table of Driving Programs .....	66
Table of Driving Ranges .....	65
Table of Driving Ranges with Dual Drive .....	71

**Index**

	Page		Page
Table of Multi-function Lever Functions (Variant 2) .....	99	Turning On and Operating the Lights .....	121
Table of Noise Levels and Absorption Rating .....	27	Turning On High Beam .....	121
Table of Trailers .....	135	Turning on the Battery Isolating Switch .....	50
Taking into Service .....	49	Turning on the Flood Light .....	125
Taking out of Operation .....	133	Turning on the Hazard Warning Flasher System .....	124
Technical Data .....	15	Turning on the Heating .....	127
Technical Data of Engine .....	210	Turning on the Interior Light .....	125
Technical Data/Filling Quantities .....	23	Turning on the Rotating Beacon .....	124
Tightening Nuts and Bolts .....	174	Turning on the Upper Lights .....	123
Tightening the Wheel Nuts .....	174	Turning on the Ventilation System .....	128
Tightening Torques .....	207	Turning on the Windshield Wiper/Washer .....	120
Tires .....	20	<b>U</b>	
Track Widths .....	18	Unintended Applications .....	5
Tractor .....	29	<b>V</b>	
Tractor Dimensions .....	16	Views of Tractor .....	28
Tractor Lubrication .....	173	<b>W</b>	
Tractors for farming and forestry (also with implements) .....	7	Weights .....	19
Trailers, Towing .....	135	Winter Diesel Fuel .....	84
Transport, Loading, Towing .....	139	Work on the Electrical Equipment .....	153
Turning off the Oil Circulating Device .....	114	Working Clothes .....	11
Turning Off the Power Hydraulics .....	111		
Turning Off the Priority Flow Valve .....	116, 118		
Turning Off the Variable Pump for Implements .....	109		