



# HOLDER

## WASHING WITH AN ENORMOUS RANGE

THE NEW WASHING SYSTEM CRISTAL – CH 3000 LP FOR THE HOLDER MUVO



### CONTAINER VOLUME

Water tank	2100 l
Water tank with hybrid option	1850 l

### VEHICLE DIMENSIONS WITH WASHING SYSTEM

Total height	2120 mm
Total length	4840 mm

### WASHING UNIT

Water pressure	50 bar
Water flow rate	114 l/min

### WASHING BAR DIMENSIONS

U-shaped washing bar	1300 mm / 2300 mm
Telescopic washing bar	1300 mm – 2800 mm

# YOUR BENEFITS

- € COST SAVINGS
- 🕒 TIME SAVINGS
- ⚠️ SAFETY
- 😊 COMFORT
- 👍 WORKING RESULTS

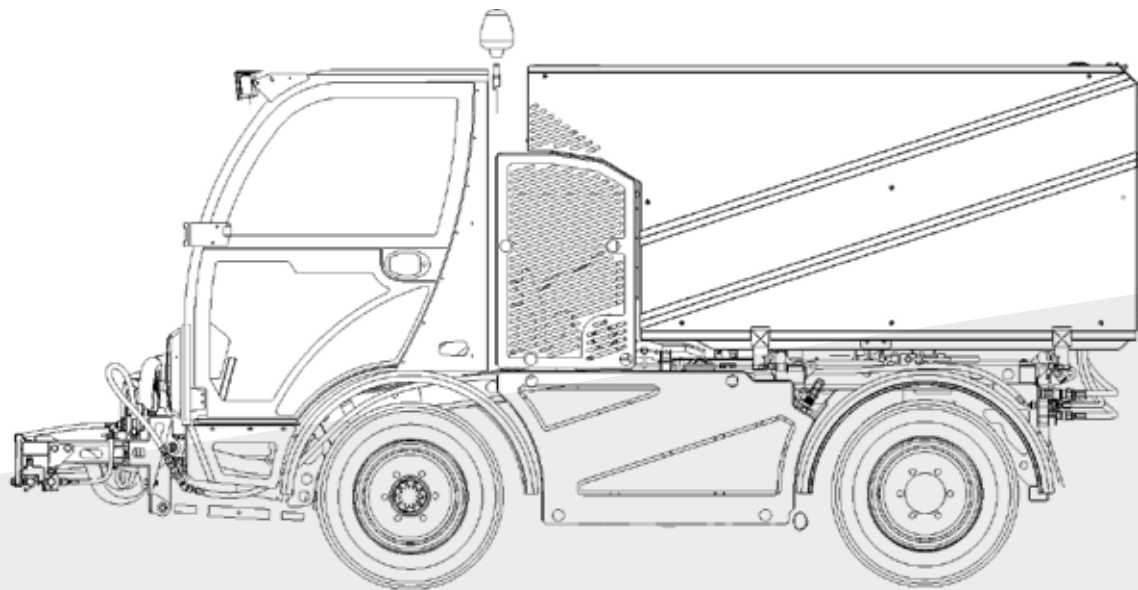

## CARRIER VEHICLE

- € Versatile system vehicle for cleaning all surfaces:  
👍 Pavements, streets, parking spaces and public spaces
- € Easy to manoeuvre thanks to 4-wheel steering and  
🕒 crab steering
- 😊 The "Hybrid" option enables you to work quietly and represents outstanding sustainability



## WATER TANK

- ⚠️ Robust aluminium tank
- € The large water capacity and the high water flow rate  
🕒 ensure an enormous operating range

## WASHING UNIT

- 👍 U-shaped stainless steel washing bar with two independent side arms
- 👍 Telescopic washing bar up to an operating width of 3100 mm
- 👍 L/R side nozzles for cleaning under obstacles

## MANUAL OPERATION OPTIONS

- 😊 360° pivoting stainless steel hose holder, installed on the roof, incl. 12 m high-pressure hose
- 😊 Stainless steel spray lance with flow regulator and holder

## HYBRID KIT FOR MANUAL OPERATION OPTION

- 😊 Two 24 V lithium batteries with 300 Ah
- 😊 Can be charged by an alternator or 220 V socket

## HIGH-PRESSURE OPTIONS FOR MANUAL OPERATION

- 👍 150 or 200 bar high-pressure pump
- 😊 Manual high-pressure stainless steel cleaning hood with three integrated rotating arms and a holder on the tank
- 😊 Double-jet high-pressure lance with pressure regulation and holder

